

ORIGAMI TANTEIDAN 19th CONVENTION

第19回  
折紙探偵団  
コンベンション

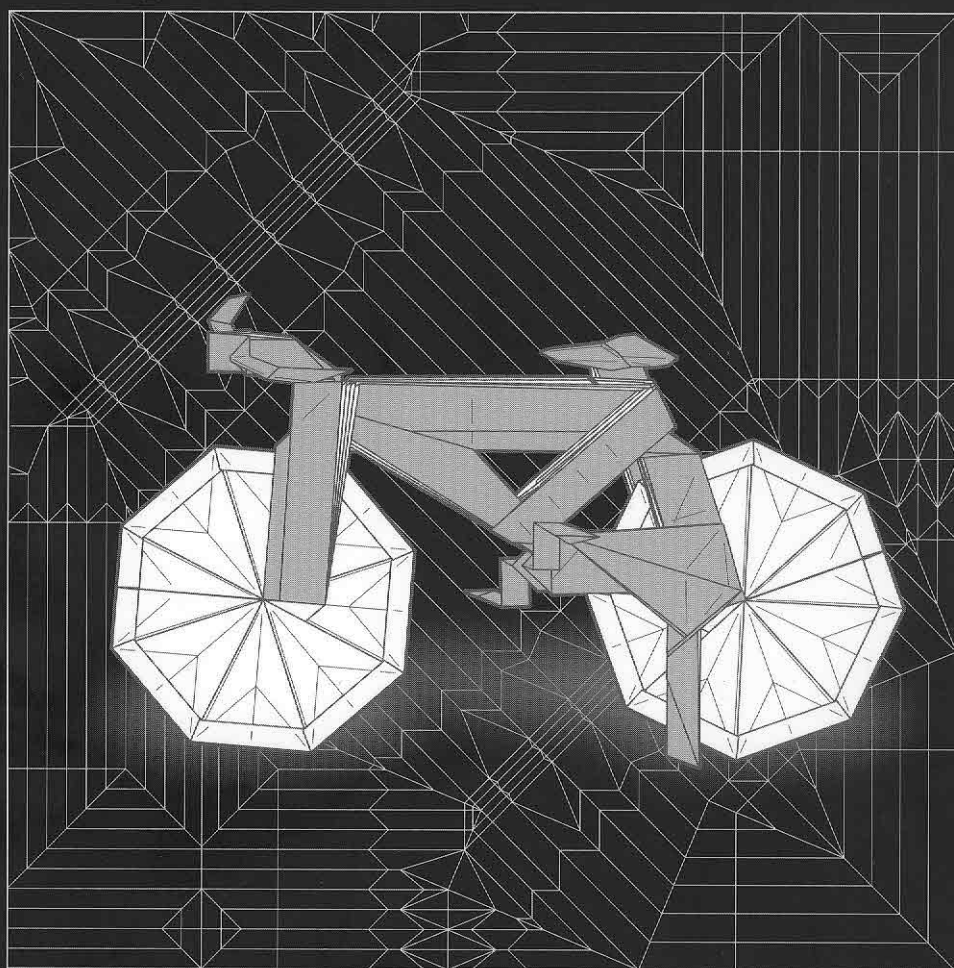

© Jason Ku

折り図集  
.....  
Vol.19

発行・日本折紙学会

19th Origami Tanteidan Convention

第19回  
折紙探偵団  
コンベンション

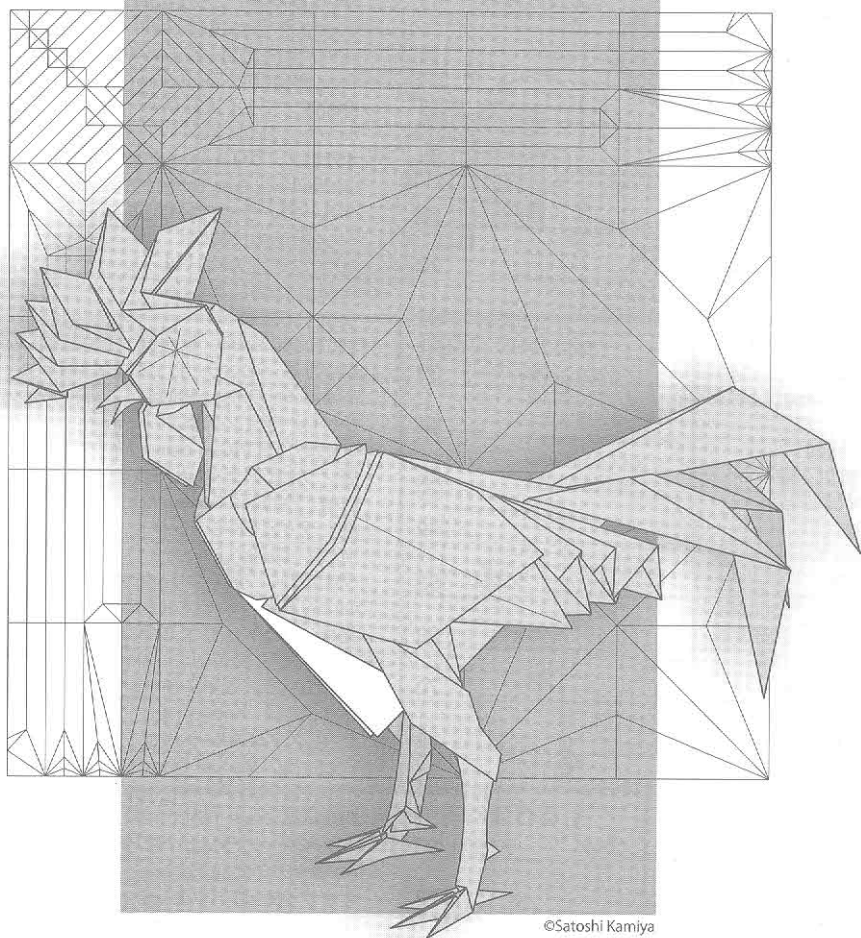

©Satoshi Kamiya

折り図集

Vol. 19

発行・日本折紙学会

Japan Origami Academic Society

## CONTENTS

折り図記号 Symbols for Folding	3
---------------------------	---

基本形・沈め折り Preliminary Bases and Sink	4
-------------------------------------	---

## 国内編: Models by Japanese Folders

スターオーブ/川村みゆき	6
STAR ORB/Miyuki Kawamura	
ジャバラン/川村みゆき	8
JAVARAN/Miyuki Kawamura	
モザイク小物入れ/川崎敏和	11
Accessory case/Toshikazu Kawasaki	
金魚の箸袋/稲吉秀尚	14
Goldfish Chopstick Holder/Hidehisa Inayoshi	
とらぼうし/中井 努	17
Cap of Tigers/Tsutomu Nakai	
くつ/西川誠司	22
Shoes/Seiji Nishikawa	
ネクタイ付き Yシャツ/稲吉秀尚	26
Shirt with Necktie/Hidehisa Inayoshi	
サンタクロース/山口之彦	29
Santa Claus/Yukihiko Yamaguchi	
もみじ/中川幸治	32
Maple Leaf/Kouji Nakagawa	
トビハゼ/加茂弘郎	39
Mudskipper/Hiroo Kamo	
さめ/各務 均	44
Shark/Hitoshi Kakami	
タツノオトシゴ/前川 淳	46
Sea horse/Jun Maekawa	
イルカ/山北克彦	49
Dolphin/Katsuhiko Yamakita	
タマカイ/柏村卓朗	53
Giant grouper/Takuro Kashiwamura	
ティーバッグのカエル/小野友彰	68
Tea-bag Frog/Tomoaki Ono	
りぼんねこ/松井英里香	70
Ribbon Cat/Erika Matsui	
にわとり/萩原 元	73
Rooster/Gen Hagiwara	
ニフトリ/神谷哲史	77
Rooster/Satoshi Kamiya	
象/合谷哲哉	90
Elephant/Tetsuya Gotani	
リヤマ/川畑文昭	98
Lama/Fumiaki Kawahata	
ラクダ/土田耕平	106
Camel/Kohei Tsuchida	
サイ/宮島 登	113
Rhinoceros/Noboru Miyajima	
ショウリョウバッタ/村木厚紀	122
Longheaded Locust/Atsunori Muraki	
カタツムリ/小松英夫	125
Snail/Hideo Komatsu	
プレシオサウルス/青木 良	132
Plesiosaurus/Ryo Aoki	
ドラゴン/木下 剛	135
Dragon/Go Kinoshita	

ペガサス/霞 誠志	141
-----------	-----

Pegasus/Seishi Kasumi	
-----------------------	--

輪入道/尾川 知	148
----------	-----

Wanyudo/Tomo Ogawa	
--------------------	--

## 海外編: Models by Foreign Folders

無限の輪/イザ・クライン	156
--------------	-----

Laços do Infinito/Isa Klein	
-----------------------------	--

12角形のタイル/ニック・ロビンソン	158
--------------------	-----

Dodecagon dissection/Nick Robinson	
------------------------------------	--

カップケーキ/ニック・ロビンソン	159
------------------	-----

Cupcake/Nick Robinson	
-----------------------	--

コマ/マーク・カーシェンバウム	160
-----------------	-----

Top/Marc Kirschenbaum	
-----------------------	--

自転車/ジェイン・クー	163
-------------	-----

Bicycle/Jason Ku	
------------------	--

オサガメ/クリス・ヘイネン	178
---------------	-----

Leatherback Sea Turtle/Chris Heynen	
-------------------------------------	--

ベルーガ/ライアン・ウェルシュ	183
-----------------	-----

Beluga/Ryan Welsh	
-------------------	--

エビ/パヴェル・ニクルシン	188
---------------	-----

Shrimp/Pavel Nikulshin	
------------------------	--

ウサギ/羅瑜	197
--------	-----

Big Teeth Bunny/Lo Yu	
-----------------------	--

白ウサギ/ニコラ・ガハルド・エンリケス	200
---------------------	-----

Nivens Mc Twisp/Nicolás Gajardo Henriquez	
-------------------------------------------	--

ひつじ/チョン・キダン	207
-------------	-----

Sheep/JEONG ki-dam	
--------------------	--

鹿/ファビアナ・サナパニャ	210
---------------	-----

Deer/Fabiana Sanapanya	
------------------------	--

馬/デイビット・ジャンケ	214
--------------	-----

Horse/David Llanque	
---------------------	--

グリズリー/セス・フリードマン	219
-----------------	-----

Grizzly Bear/Seth Friedman	
----------------------------	--

雄牛/アンドレイ・エルマコフ	225
----------------	-----

Stock Bull/Andrey Ermakov	
---------------------------	--

ヘルコブラ/ケイド・チャン	234
---------------	-----

Hell Cobra/Kade Chan	
----------------------	--

トンボ/マヌエル・シルゴ	239
--------------	-----

Dragonfly/Manuel Sirgo	
------------------------	--

ペンギン/ハディ・タヒール	246
---------------	-----

Penguin/Hadi Tahir	
--------------------	--

ペンギン/バランカ・ペンテラ	249
----------------	-----

Penguin/Blanca Pentela	
------------------------	--

オオサイチョウ/クエンティン・トロリップ	252
----------------------	-----

Great Hornbill/Quentin Trollip	
--------------------------------	--

カケス/ホアン・ティン・クエット	260
------------------	-----

Blue Jay/Hoang Tien Quyet	
---------------------------	--

オオハシ/ネルセロン・アウヴェス・ド・プラド	262
------------------------	-----

Toucan/Nelselon Alves do Prado	
--------------------------------	--

あひる/フェルナンド・ヒルガド	267
-----------------	-----

Pato/Fernando Gilgado	
-----------------------	--

ケナガマンモス/ウィリアム・ハートマン	273
---------------------	-----

Woolly Mammoth/William Hartman	
--------------------------------	--

テリジノサウルス/チャン・チュン・ヒエユ	280
----------------------	-----

Therizinosaurus/Tran Trung Hieu	
---------------------------------	--

# 折り図記号 Symbols for Folding

## 折り線の種類 Types of crease lines

### 谷折り線 Valley fold

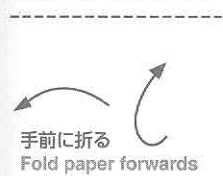

### 谷折り Valley fold

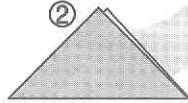

### 山折り線 Mountain fold



### 山折り Mountain fold

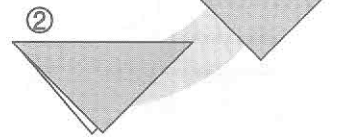

## 折り方の技法 Basic Folding Skills

### 中わり折り Inside-reverse fold

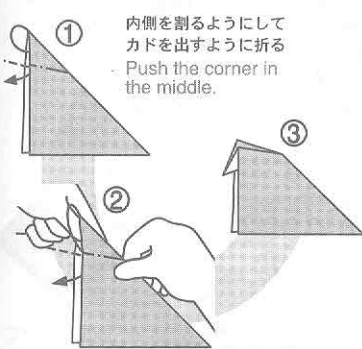

### かぶせ折り Outside-reverse fold

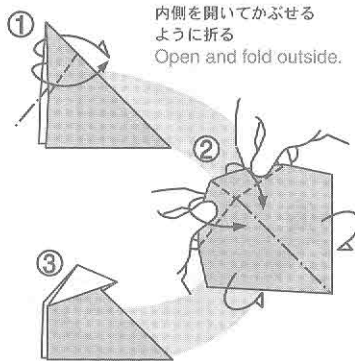

### 内側をひろげてつぶすように折る Squash fold

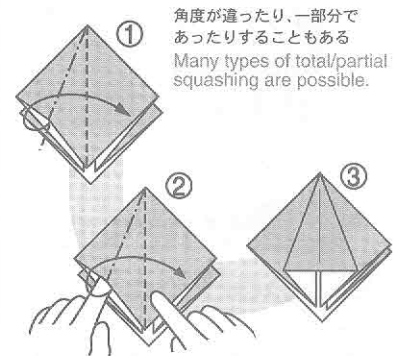

## いろいろな記号 Symbols

### 折り筋をつける Making a crease line

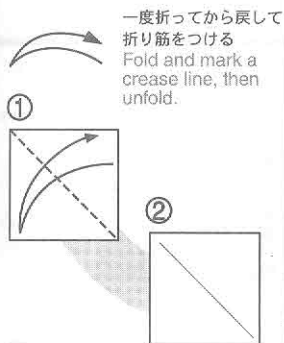

### 裏返す Turn paper over

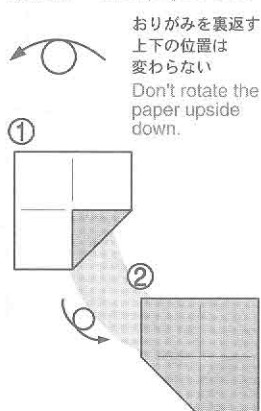

### 段折り Pleat fold

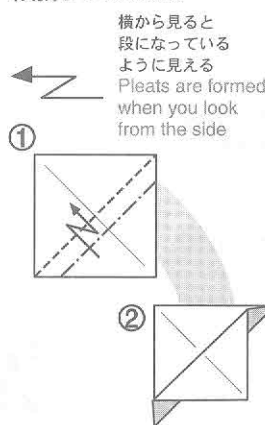

### 下の部分を出すように折る Release bottom flap when making a fold

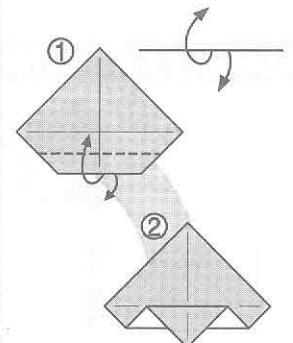

### 次の図が 大きくなる A magnified view



### 仮想線・透視線 A hidden line



### 押す・つぶす Push paper in



### 引き出す Pull out



### ひろげる Open up



### ○と○を 合わせて折る Match circled points



### 巻くように折る Roll the flap by repeated folds

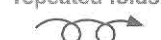

### 注意するところ Marked points

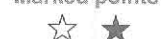

### 次の図の見る位置が変わる Paper position changes (rotation)

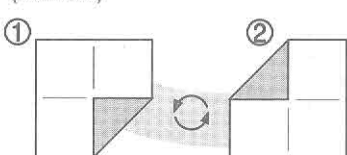

### 視点が大きく変わる場合 この記号の位置から見る The viewpoint shifts to this position.

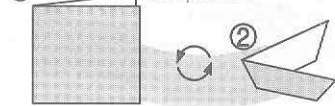

## 等分記号 Division

### 長さの等分 Dividing the length



### 角度の等分 Dividing the angle

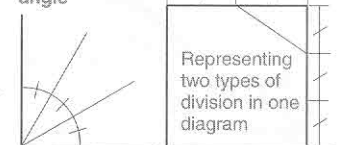

# 基本形 / 沈め折り Preliminary Bases and Sink

## 基本形 Preliminary bases

### 風船基本形 Water Bomb Base

① ② ③ ④ ⑤ ⑥ ⑦

① ② ③ ④ ⑤ ⑥ ⑦

① 半分を折る  
Fold in half.

② 半分を折る  
Fold in half again.

③ 内側をひろげて  
つぶすように折る  
Open and squash.

④ 反対側に折る  
Swivel to the left.

⑤ 内側をひろげて  
つぶすように折る  
Open and squash.

⑥ 反対側に折る  
Swivel to the left.

⑦ 内側をひろげて  
つぶすように折る  
Open and squash.

**風船基本形  
できあがり**  
The Water Bomb Base  
completed.

## 正方基本形と鶴の基本形 Preliminary Base / Bird Base

① ② ③ ④ ⑤ ⑥ ⑦ ⑧ ⑨ ⑩ ⑪

① ② ③ ④ ⑤ ⑥ ⑦ ⑧ ⑨ ⑩ ⑪

① 内側をひろげて  
つぶすように折る  
Open and squash.

② 三角を折る  
Fold in half.

③ 三角を折る  
Fold corner to corner.

④ 反対側に折る  
Swivel to the left.

⑤ 内側をひろげて  
つぶすように折る  
Open and squash.

⑥ 反対側に折る  
Swivel to the left.

⑦ 内側をひろげて  
つぶすように折る  
Open and squash.

⑧ 縁を中心に合わせて  
折り筋をつける  
Fold the lower edges  
to the center diagonal.

⑨ 内側をひろげて  
つぶすように折る  
Open, swivel up  
and squash.

⑩ 反対側も  
⑧~⑨と同じ  
Repeat ⑧~⑨  
on the back.

⑪ 鶴の基本形  
できあがり  
The Bird Base  
completed.

**正方基本形できあがり**  
The Preliminary Base  
completed.

## 沈め折り Open sink / Closed sink

① ② ③ ④ ⑤ ⑥

① ② ③ ④ ⑤ ⑥

① カドを  
斜めに折る  
Fold down.

② カドを内側に折る  
Inside reverse fold.

③ 沈め折りをする部分に  
しっかりと折り筋をつける  
Mark the crease line to  
use for sink.

④ つけた  
折り筋を使って  
沈めるように折る  
Push the arrowed corner  
inside ...

⑤ 途中の図  
紙の重なりを開か  
ないまま押し込む  
ように折る  
without opening the  
corner.  
Push in with layers  
overlapped to  
each other.

⑥ 紙のひだが開いた  
(open)かたち  
になっている  
The layers can be  
reopened.

**Open sink  
(オープン・シンク)**  
できあがり  
Open sink completed.

① 紙のひだが  
閉じた (closed)  
かたち  
になっている  
The layers are  
locked.

② カドを  
斜めに折る  
Fold down.

③ 沈め折りをする  
部分にしっかりと  
折り筋をつける  
Mark the  
crease line  
to use for sink.

④ つけた折り筋を  
使って沈める  
ように折る  
Push in the corner.

⑤ 途中の図  
紙の重なりを開か  
ないまま押し込む  
ように折る  
without opening the  
corner.  
Push in with layers  
overlapped to  
each other.

⑥ 紙のひだが開いた  
(open)かたち  
になっている  
The layers can be  
reopened.

**Closed sink  
(クローズド・シンク)**  
できあがり  
Closed sink completed.

ひだの形によってはclosed sink  
にしかできない場合があります  
Certain complexes of layers  
allows only for closed sink.

① カドを  
斜めに折る  
Fold down.

② 沈め折りをする  
部分にしっかりと  
折り筋をつける  
Mark the  
crease line  
to use for sink.

③ つけた折り筋を  
使って沈める  
ように折る  
Push in the corner.

④ できあがり  
The closed sink completed.

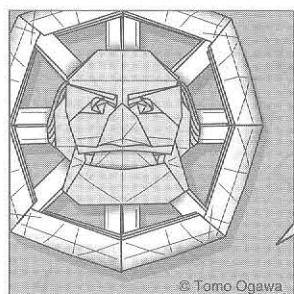

© Tomo Ogawa

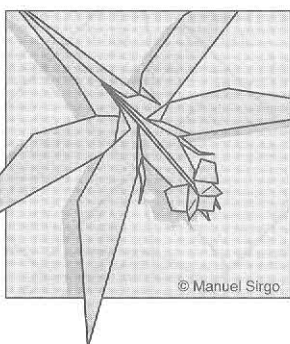

© Manuel Sirgo

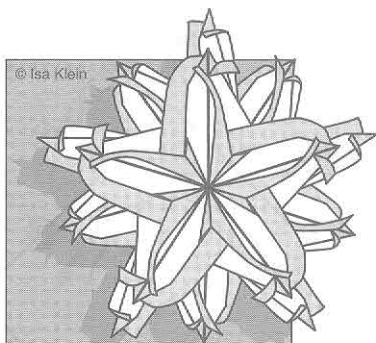

© Isa Klein

## 第19回折紙探偵団コンベンション折り図集 19th Origami Tanteidan Convention Book

国内編 / Models by Japanese Folders P.6

海外編 / Models by Foreign Folders P.156

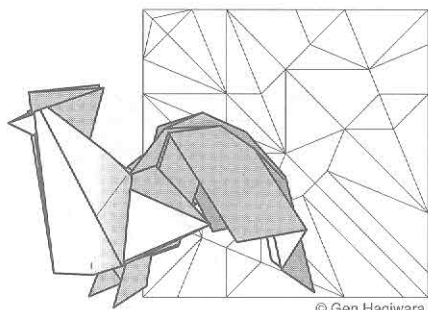

© Gen Hagiwara

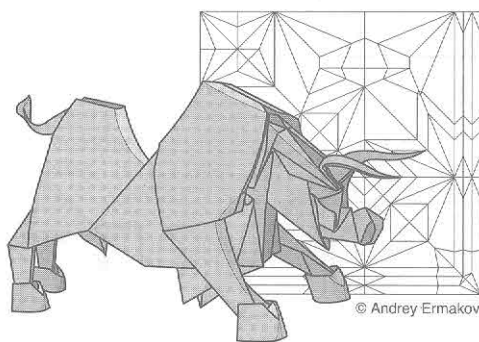

© Andrey Ermakov

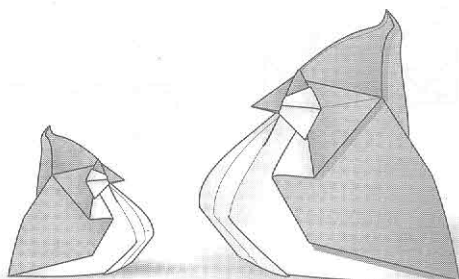

© Hoang Tien Quyet

Design : 20120413

「オーブ」というのは球という意味です。薄くてシャキッとした紙を使うときれいに仕上がります。  
Thin and hard paper is good for this model.

# スターオーブ

## STAR ORB

©2013 Miyuki Kawamura  
川村みゆき

①

②

③

④

⑤

⑥

⑦

⑧

⑨

⑩

綺麗にカーブをつける。  
Make two curves strongly.

舟型に開く  
Open the pocket and  
make a ship shape.

手 Flap

ポケット Pocket

下から見た図  
Bottom view

ポケット Pocket

手 Flap

横から見た図  
Side view.

手 Flap

ポケット Pocket

「スターオーブ」のユニット  
The STAR ORB module  
同じものを 30 個作ります。  
You need 30 modules.

組み方 / Assembly

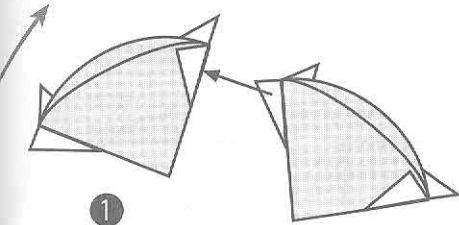

1

手をポケットに差し込む  
Tuck a flap into a pocket.

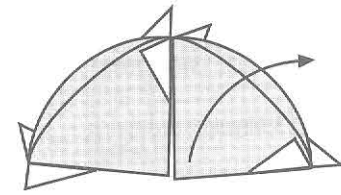

2 三角形の部分をめくり上げる  
Unfold the triangle.

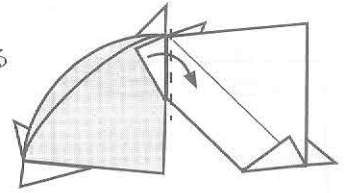

3 ポケットの三角形を倒す  
Fold the small triangle.

12 枚組  
12 modules

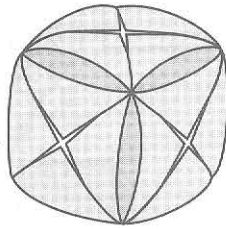

ここは3つのユニット  
が集まっています。  
This point is formed  
by 3 modules.

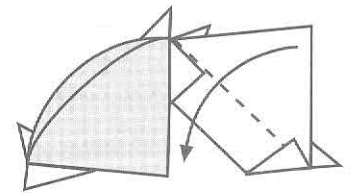

4 上から被せるように折り下げる  
Fold the large triangle down.

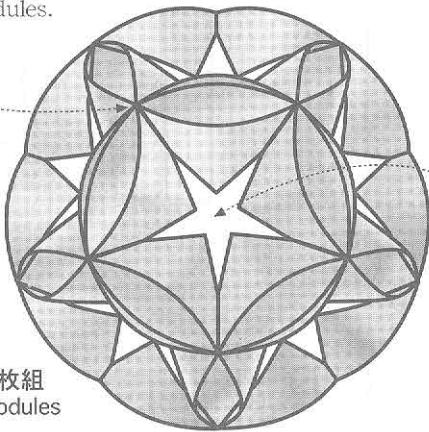

30 枚組  
30 modules

スターオーブ  
STAR ORB

この穴は5つのユニット  
できています。  
This hole is formed  
by 5 modules.

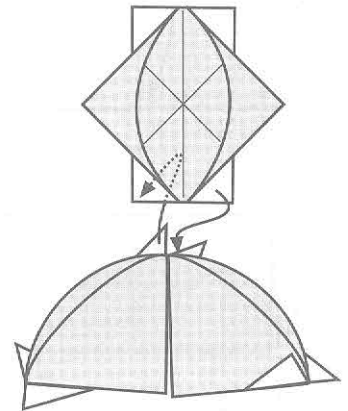

5 3つめのユニットを  
同様に組む  
Do the same way to  
the third module.

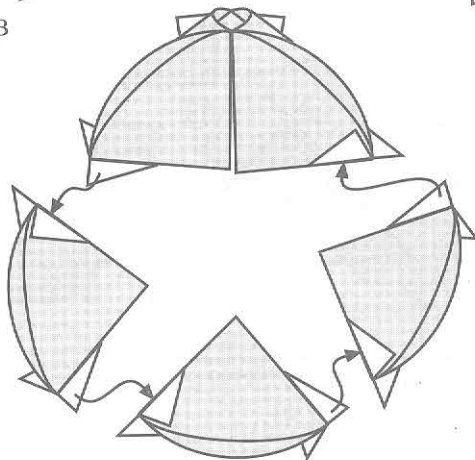

6 穴が五角形になる  
ように組む。  
残りのユニットも  
同様に組んでいく。  
Assemble and make  
a pentagonal ring.  
Tuck and assemble  
the other modules in  
the same way.



# ジャバラン

## JAVARAN

©2013 Miyuki Kawamura  
川村みゆき

蛇腹の数を変えたり用紙の形を変えたりして、色々なバリエーションを作ることができます。  
The name of "Javaran" is come from Japanese word "Jabara", it means pleats. There are many variations of models by changing the numbers of pleats and the proportion of paper.

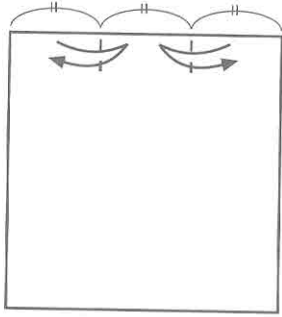

①

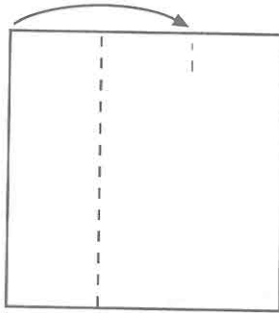

②

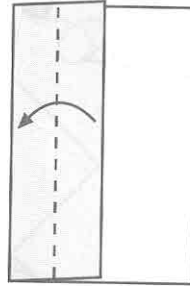

③

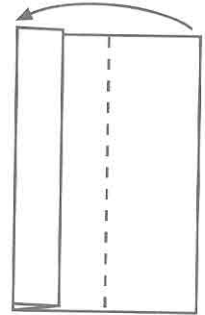

④

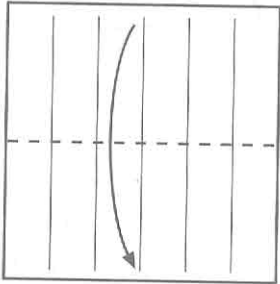

⑨



⑧ 開く。  
Unfold.



⑦ 半分に折る  
Fold into half.

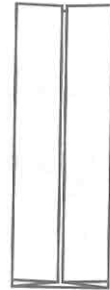

⑥

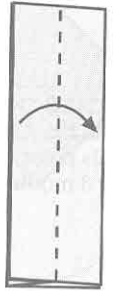

⑤ 1枚だけ折る  
Fold only the  
upper layer.

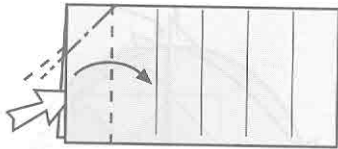

⑩ 開いてつぶす。  
Open and squash.

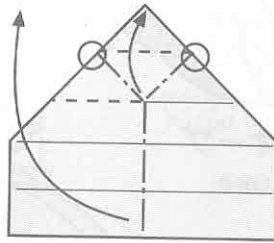

⑬

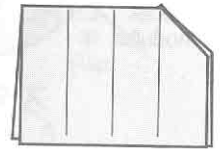

⑭

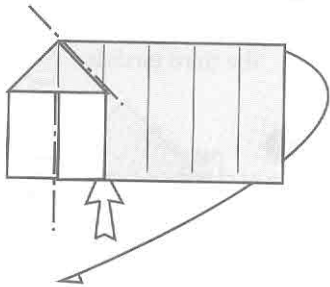

⑪ 上の部分だけ開いてつぶす。  
Open and squash the  
top corner.

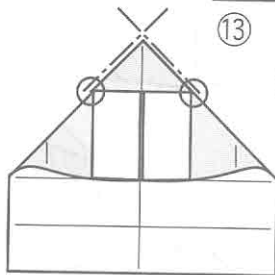

⑫ 上の部分だけ折り目  
をつける。  
Squash the top corner  
only.

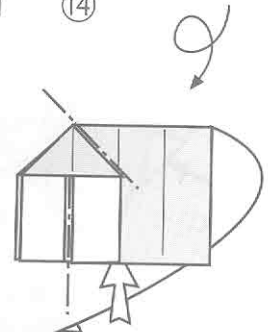

⑮ 同じ手順でつぶしていく。  
Do the same on the all pleats.

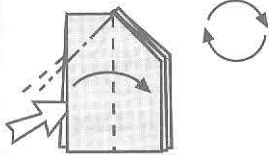

①⑥ 最後のひだも開いてつぶす。  
Open and squash.



①⑦ 一枚だけめくって、一番手前に折り込む。新しい折り目はつきません。  
Open a bit and tuck one flap into the inside of the first pocket. Don't make a new crease line.

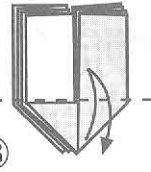

①⑧ 1枚だけ折り目をつける。  
Fold one flap and unfold.

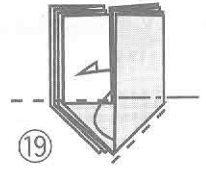

①⑨ 中割り折り  
Inside reverse fold.

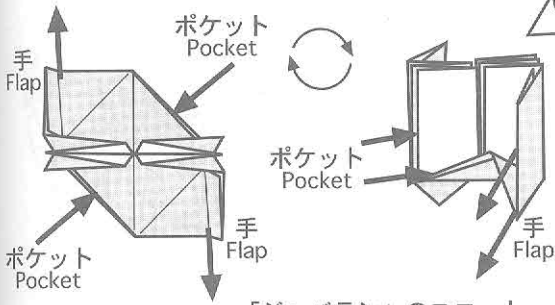

上から見た図  
Top view.

「ジャバラン」のユニット  
The JAVARAN module  
同じものを30個作ります。  
You need 30 modules.

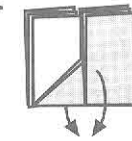

①⑪ 少し開く  
Open a bit.

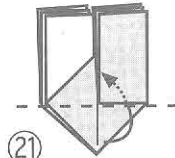

①⑫ 残ったカドを折り上げて中へ入れる。  
Fold the last flap up into the inside.

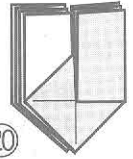

①⑬ 裏も同じ。  
Do the same on the reverse side.

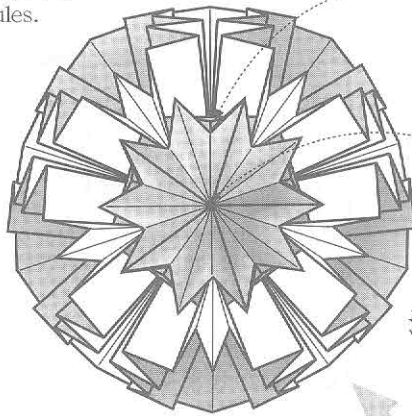

30枚組  
30 modules

ここは3つのユニットが集まっています。  
This part is formed by 5 modules.

ここは3つのユニットが集まっています。  
This point is formed by 3 modules.

組み方 / Assembly

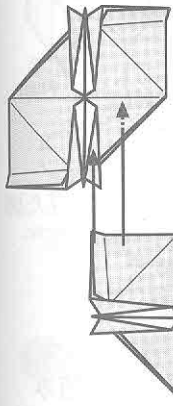

① 手をポケットに差し込む。※手もポケットもL字型に折れ曲がって、立体的に立ち上がっています。

Tuck a flap into a pocket. Flap and pocket are 3D "L" shaped.

ジャバラン  
JAVARAN

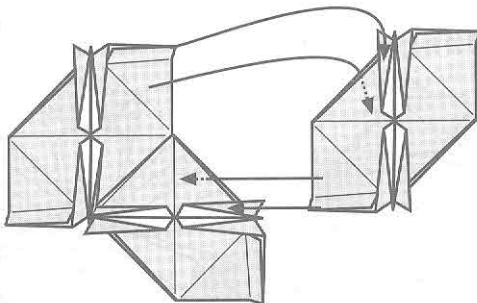

② 3つめのユニットを同様に組む  
Do the same way to the third module.

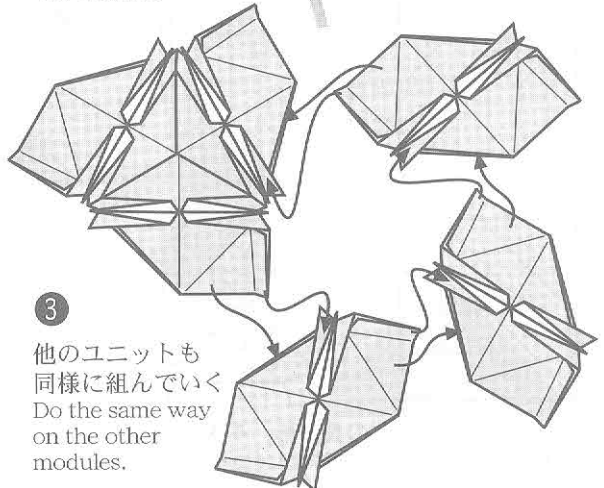

③ 他のユニットも同様に組んでいく  
Do the same way on the other modules.

4等分以上の偶数個の蛇腹でユニットが作れます。

You can make many JAVARAN modules by using pleats of even number bigger than 4.

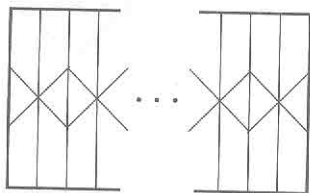

正方形  
4等分  
12枚組  
Square  
4 pleats  
12 modules

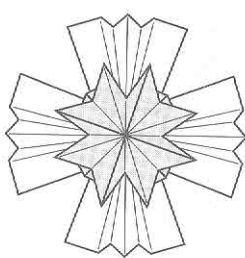
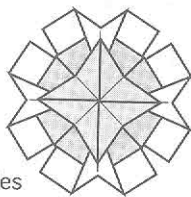

正方形、6等分  
12枚組  
Square, 6 pleats  
12 modules

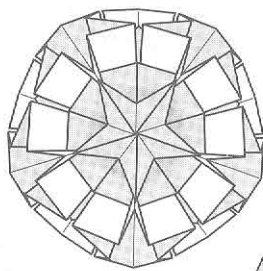

2:3の長方形  
4等分  
30枚組  
2x3 Rectangl  
4 pleats, 30 modules

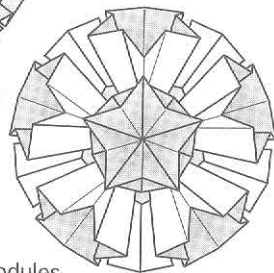

正方形、4等分  
30枚組  
Square, 4 pleats  
30 modules

両端に1列ずつ付け加えると、立体中央に紙の裏の色が出るユニットが作れます。

Add one pleat to each end, then you can make another module for a color changed model.

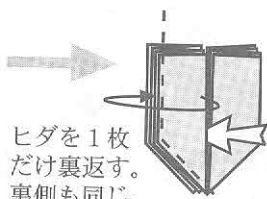
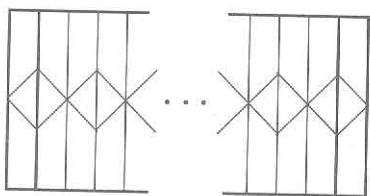

ヒダを1枚  
だけ裏返す。  
裏側も同じ。  
Open one flap and cover fold.  
Do the same on the reverse side.

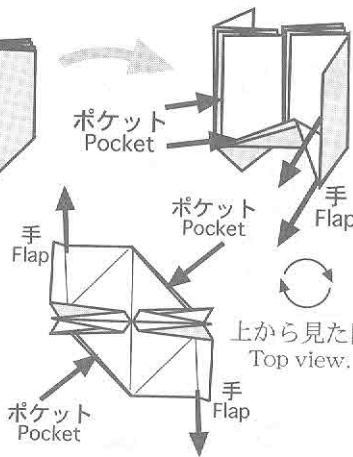

折り線の位置はある程度自由に動かせます。

There are many possibilities to change the position of crease lines.

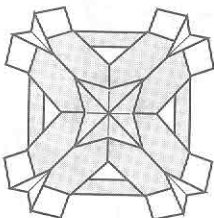
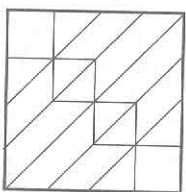
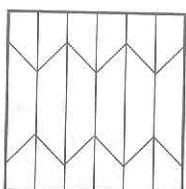
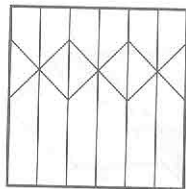

など  
etc.  
1:2の長方形、4等分、12枚組  
1X2 Rectangl, 4 pleats, 12 modules

下図の位置を山折りするとスマートな12枚組みが作れます。

Make a mountain line which is in below diagram, you can make a "slim" model with 12 modules.

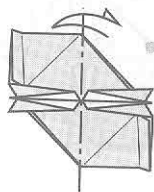

2:3の長方形  
6等分、12枚組  
2x3 Rectangl  
6 pleats, 12 modules

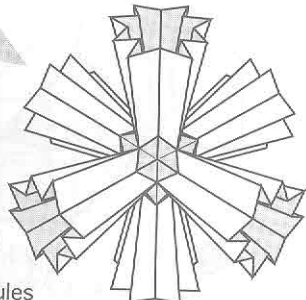

# モザイク小物入れ

Accessory case by Toshikazu Kawasaki

作・作図 川崎敏和

一連のデルタボックス作品をいじって出て出会いました。

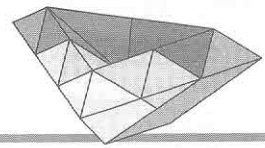

## Step◆1 中パーツを作る

練習用紙 15cm×15cmの普通の色紙  
本番用紙 20cm以上の色紙、30cmのタント

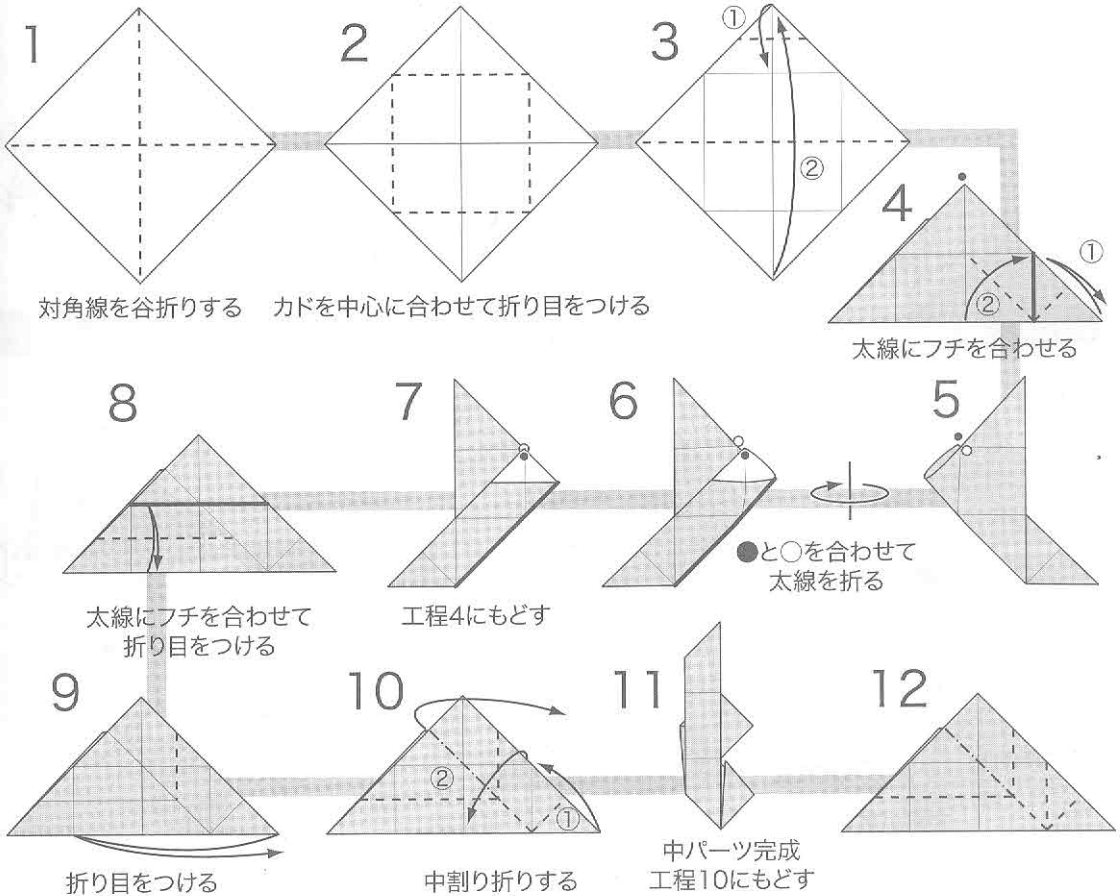

## Step◆2 外パーツを作る

練習用紙 15cm×15cmの普通の色紙  
本番用紙 20cm以上の色紙、30cmのタント

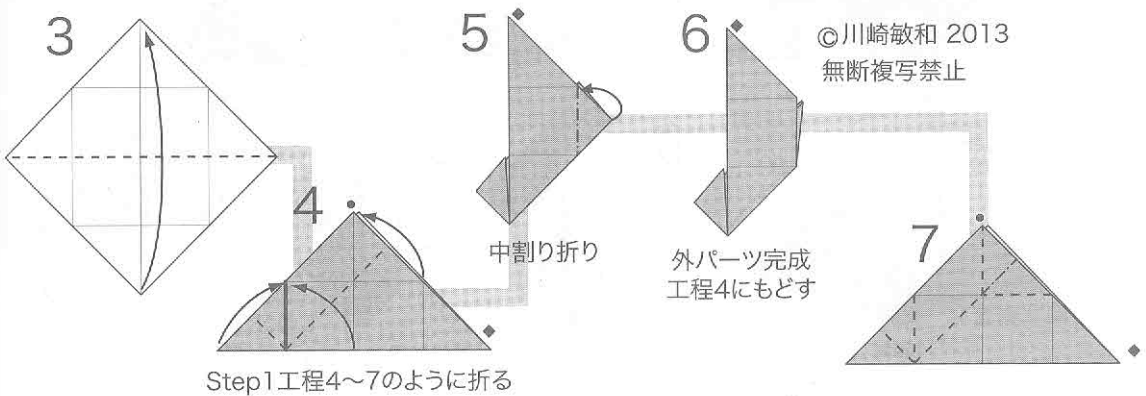

### Step◆3 内パーツを作る

練習用紙 15cm×15cmの普通の色紙  
本番用紙 20cm以上の色紙、30cmのタント

Step1の工程2から始める

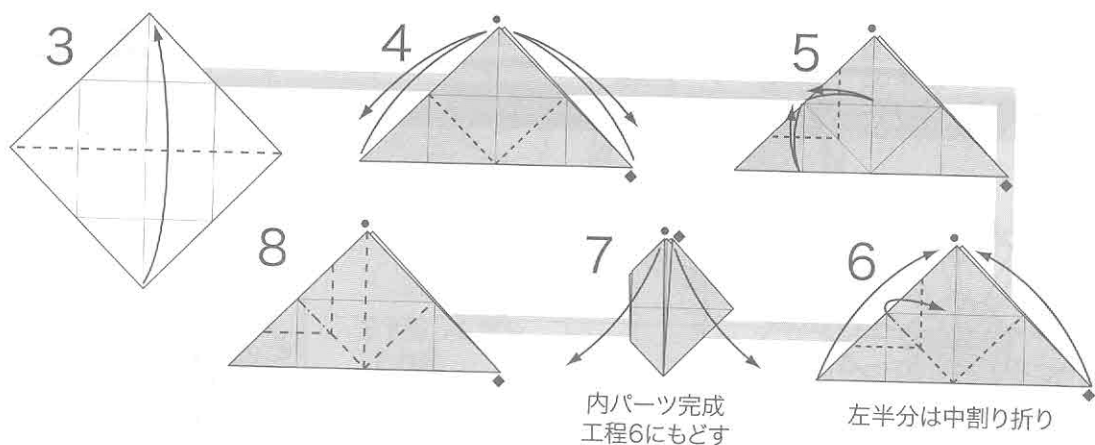

### Step◆4 パーツを組んでユニットを作る

練習用紙 内パーツ3個+中パーツ3個+外パーツ3個  
本番用紙 同上

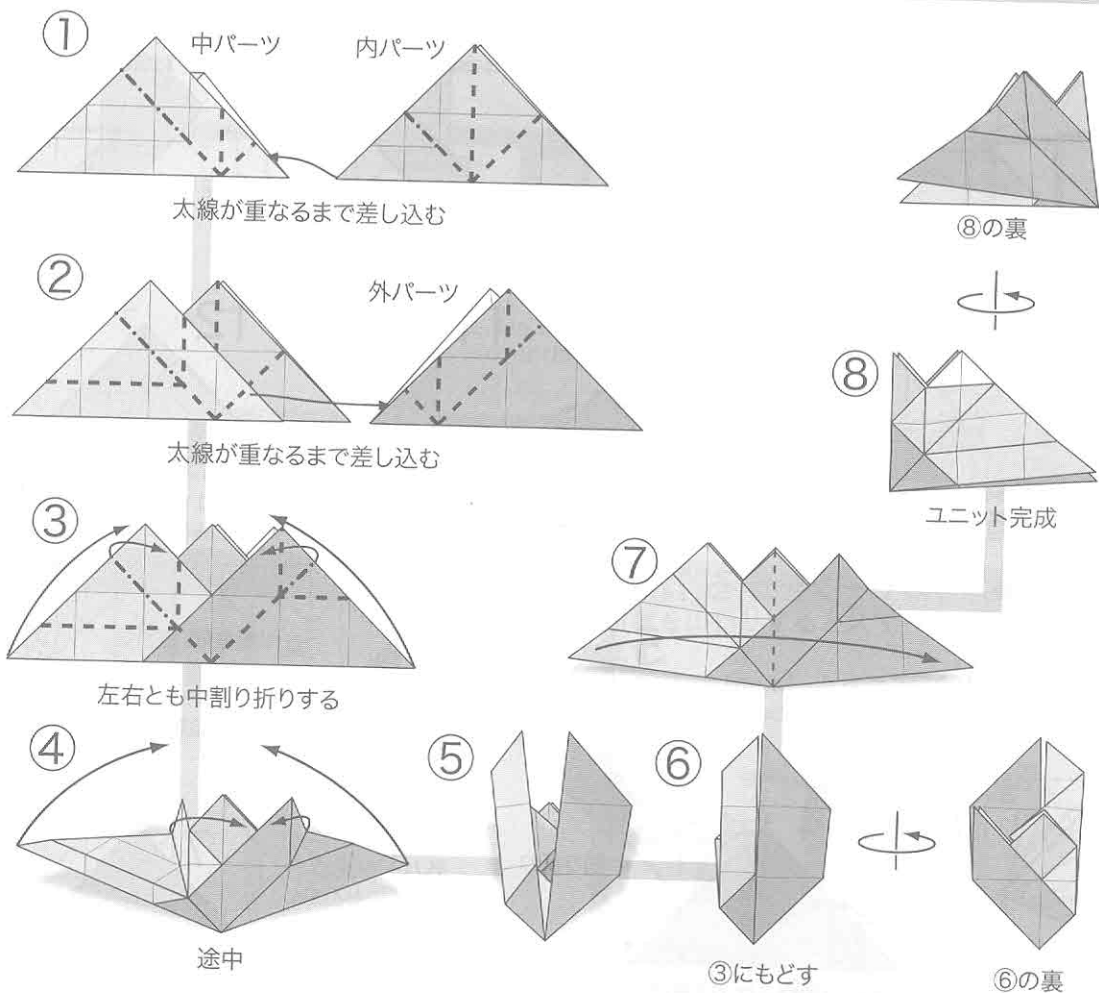

# Step◆5 小物入れを作る

練習用紙 コニット×3個  
本番用紙 同上

ユニット3個を組んで作ります。

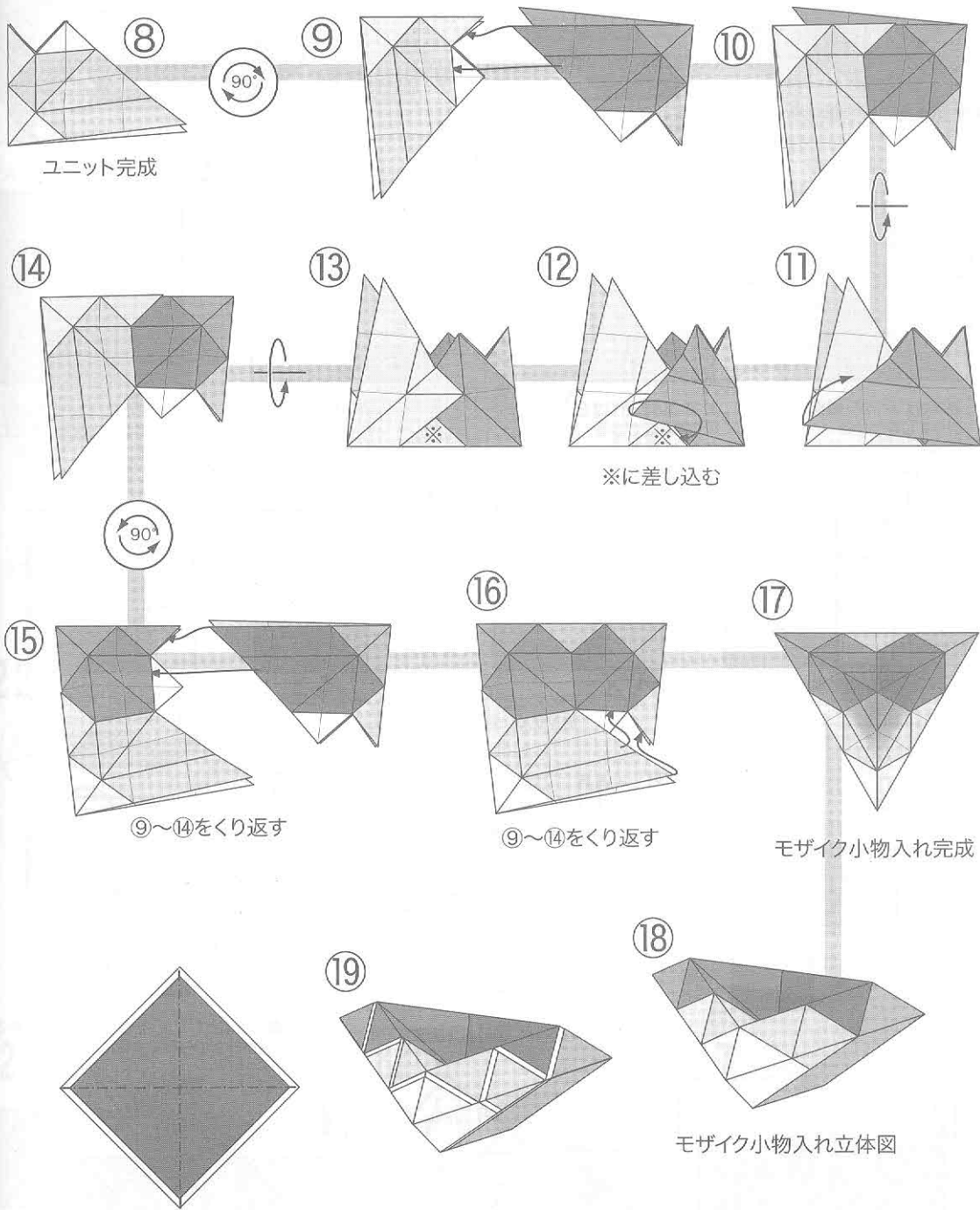

15cm角の白と14cm角の色紙を  
重ねて折っていくと⑱のような  
白い目地ができる  
対角線を折って重ねるとずれにくい

©川崎敏和 2013 無断複写禁止

# 金魚の箸袋

創作：2013.1

Goldfish Chopstick Holder

創作・折り図： 稲吉秀尚

Model & Diagrams by Hidehisa Inayoshi

★15cm角の折り紙で折ることを想定しています

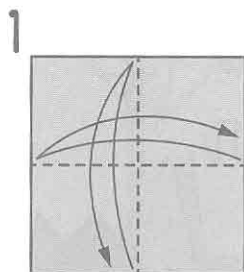
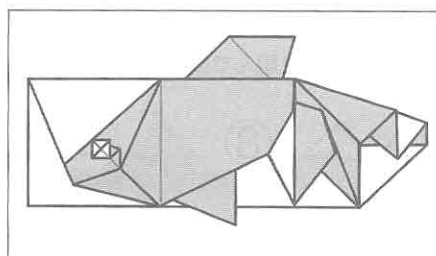

表向きにおいて、縦横に折りすじをつける

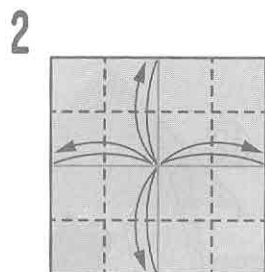

1 でつけた折りすじに合わせて折りすじをつける

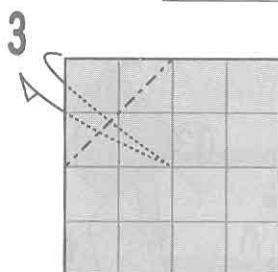

斜めに山折りで折りすじをつける

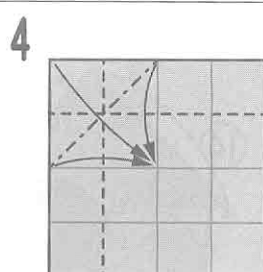

ついている折りすじを使って「正方基本形」の要領でたたむ

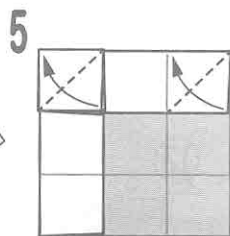

2か所で斜めに折る

拡大

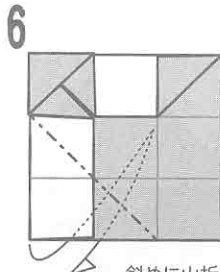

斜めに山折りで折りすじをつける

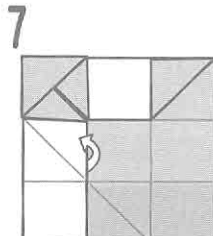

上の紙を少しめくる

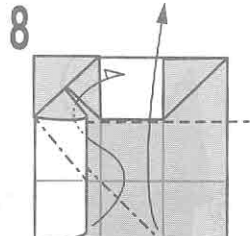

ついている折り目を使って中わり折り (新しい折り目はつかない)

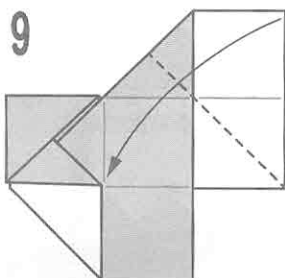

谷折り

拡大

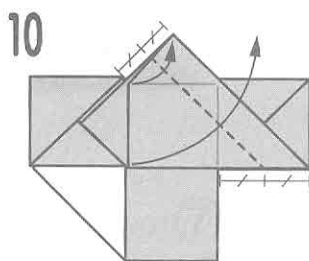

上の1枚のみ、図のような位置で折る

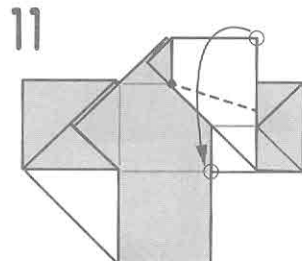

●を支点として、○を合わせるように折る (紙がひきつられて立体になる)

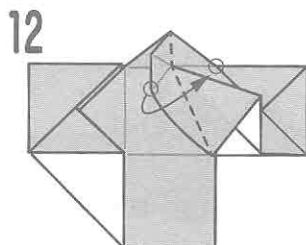

そのまま図のような折りすじで○合わせるように折りたたむ

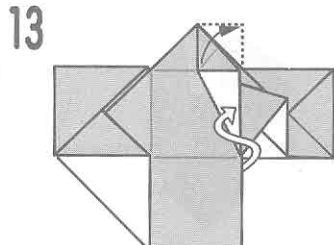

紙の上下を入れ替えると同時に右上の紙を図のように開く

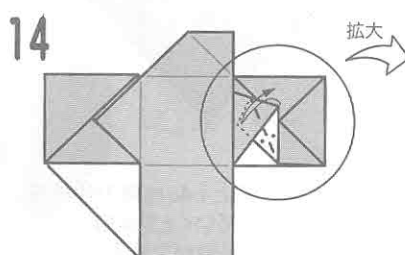

角度を2等分する折りすじをつける (次の図は、○内を拡大)

拡大

15

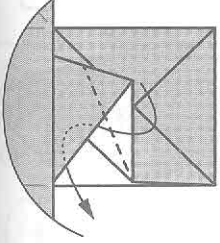

ついた折りすじを使って  
中わり折り

16

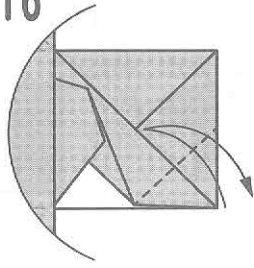

折りすじをつける

17

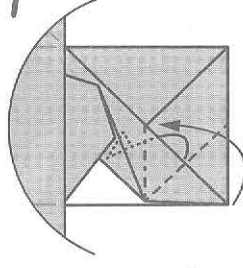

ついた折りすじも使って  
内側に引き寄せるように折る  
(山折り線は新しい折り目)

18

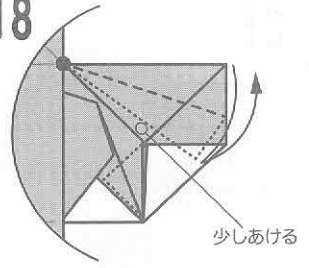

●を支点として  
折りすじをつける

少しあげる

19

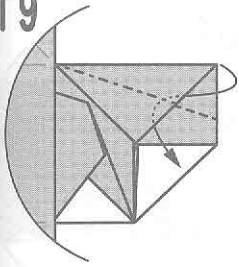

ついた折りすじを使って  
中わり折り

20

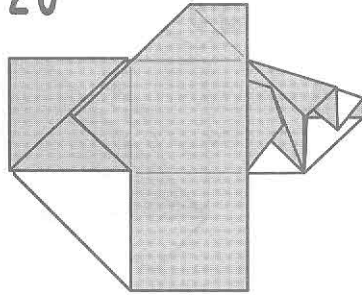

裏返す

21

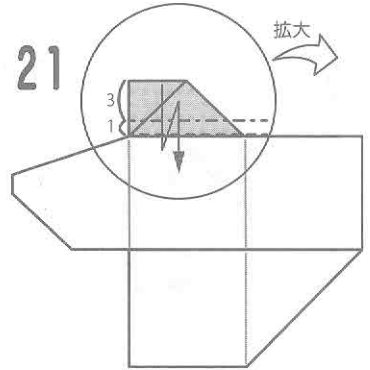

図のような折り目で段折り  
(次の図は、○内を拡大)

拡大

22

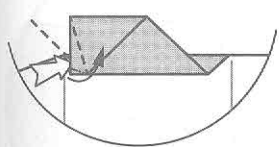

開いてつぶすように折る

23

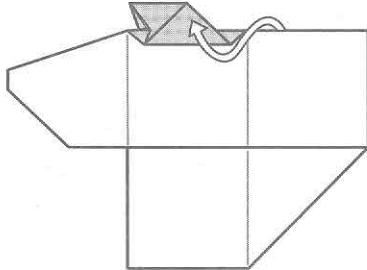

紙の上下を入れ替える

24

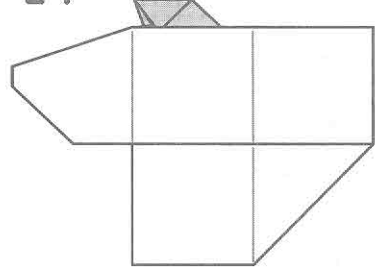

裏返す

25

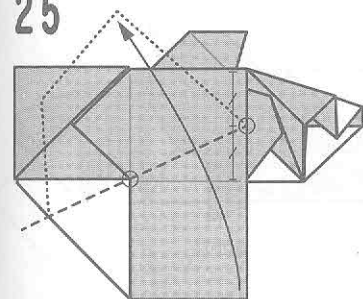

2つの○を通る線で折る

26

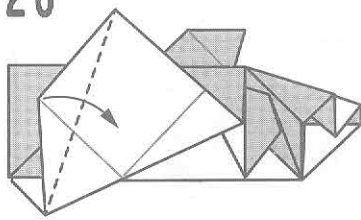

角を結ぶ線で折る

27

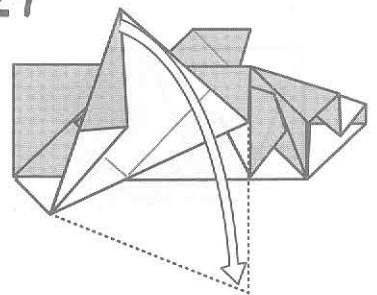

開く



28

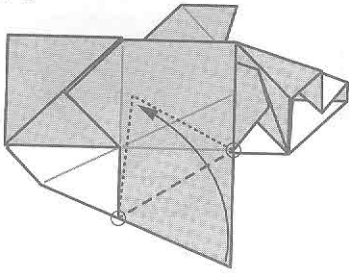

2つの○を通る線で折る

29

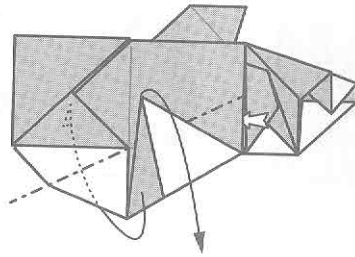

上の紙を折らないようにしながら  
25でついた折り目を使って山折り  
して、すぐ後ろへ折りこむ

30

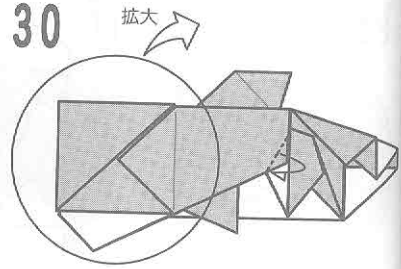

山折りして折りこむ  
(次の図は、○内を拡大)

31

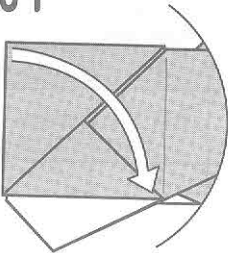

上の1枚を開く

32

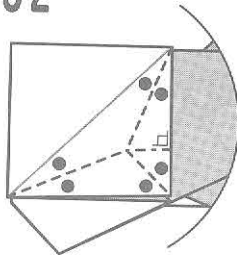

「さかなの基本形」の要領で  
「つまみ折り」

33

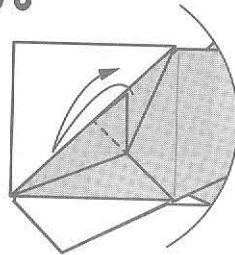

折りすじをつける

34

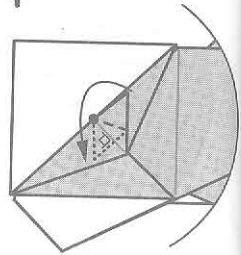

●を支点として、図のように折る

35

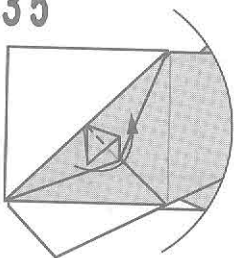

隠れている折りすじで  
折り返す

36

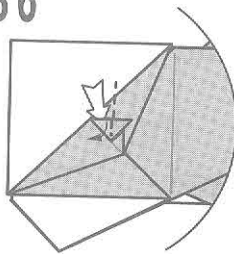

開いてつぶすように折る

37

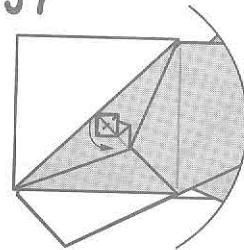

上の紙をカドいっばいの  
ところで谷折りして開く

38

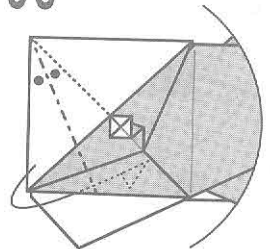

角度を2等分する折り目で山折り

39

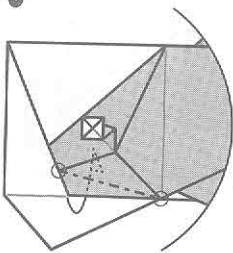

○を結ぶ線で山折り

40

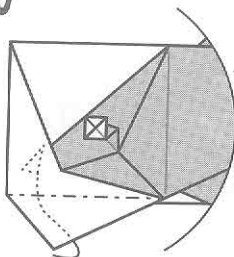

山折りですぐ後ろに折りこむ

41

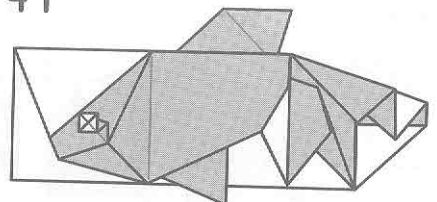

できあがり

# とらぼうし

作/図 中井 努

創作 2003年 11月

改作 2005年 11月

作図 2005年 11月

改図 2013年 6月

## Cap of Tigers

Model & Diagrams

by Tsutomu Nakai

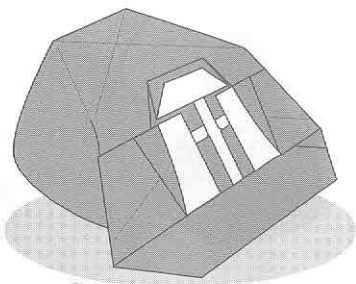

色面を上にして折り進めると  
本体が色面、ロゴが白面です

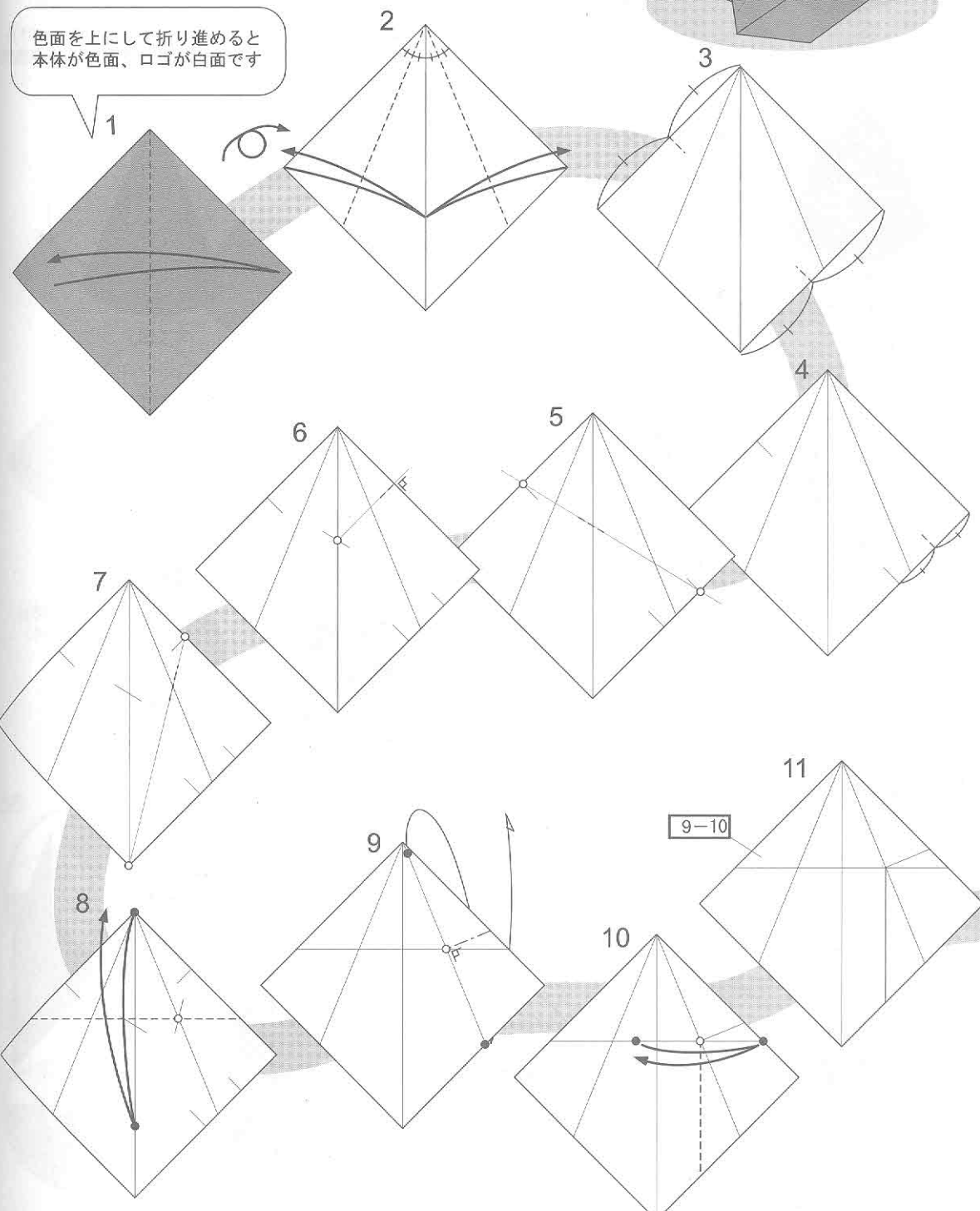

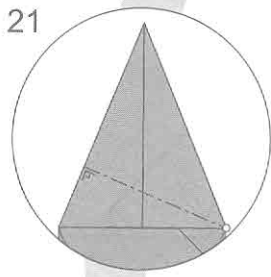
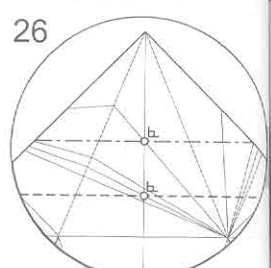
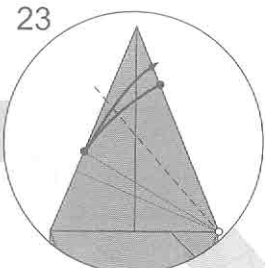
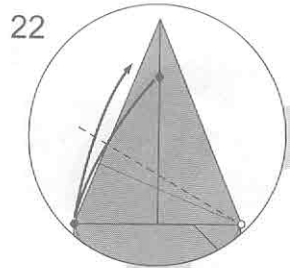

工程21-24で  
つける折り筋は  
工程26のための  
ものなので、  
中心線との交点に  
のみ付けばよい。  
(理解のため長い  
折り筋を示している。)

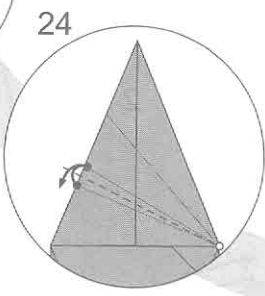

図のように折り筋をつける  
(工程21-24の折り筋を非表示)

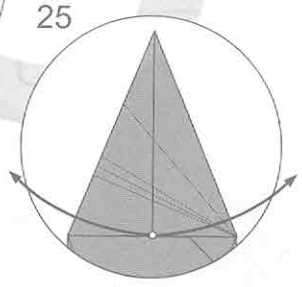

全て開く

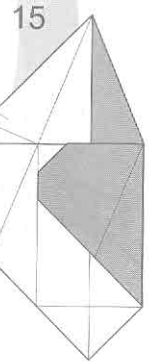
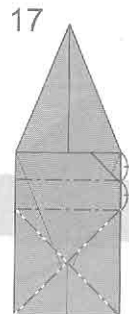
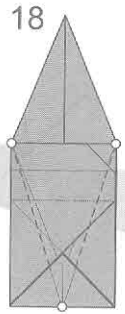
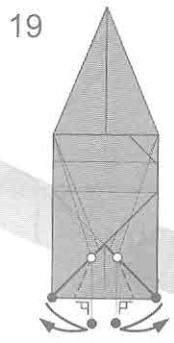
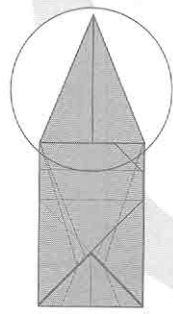
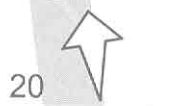

13-14

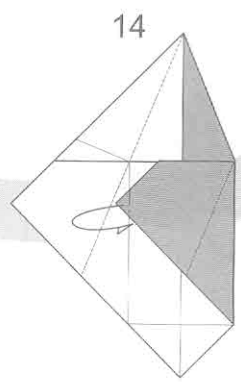
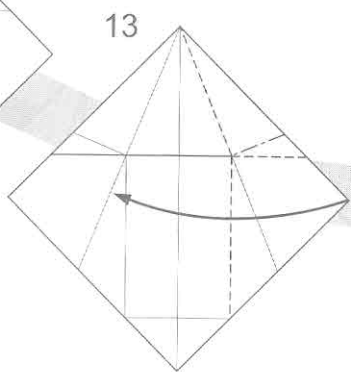
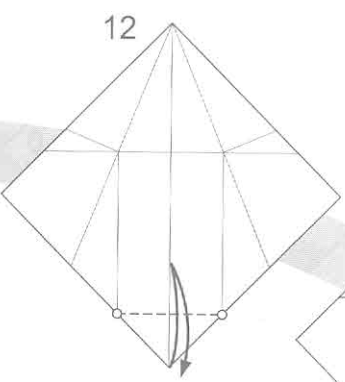

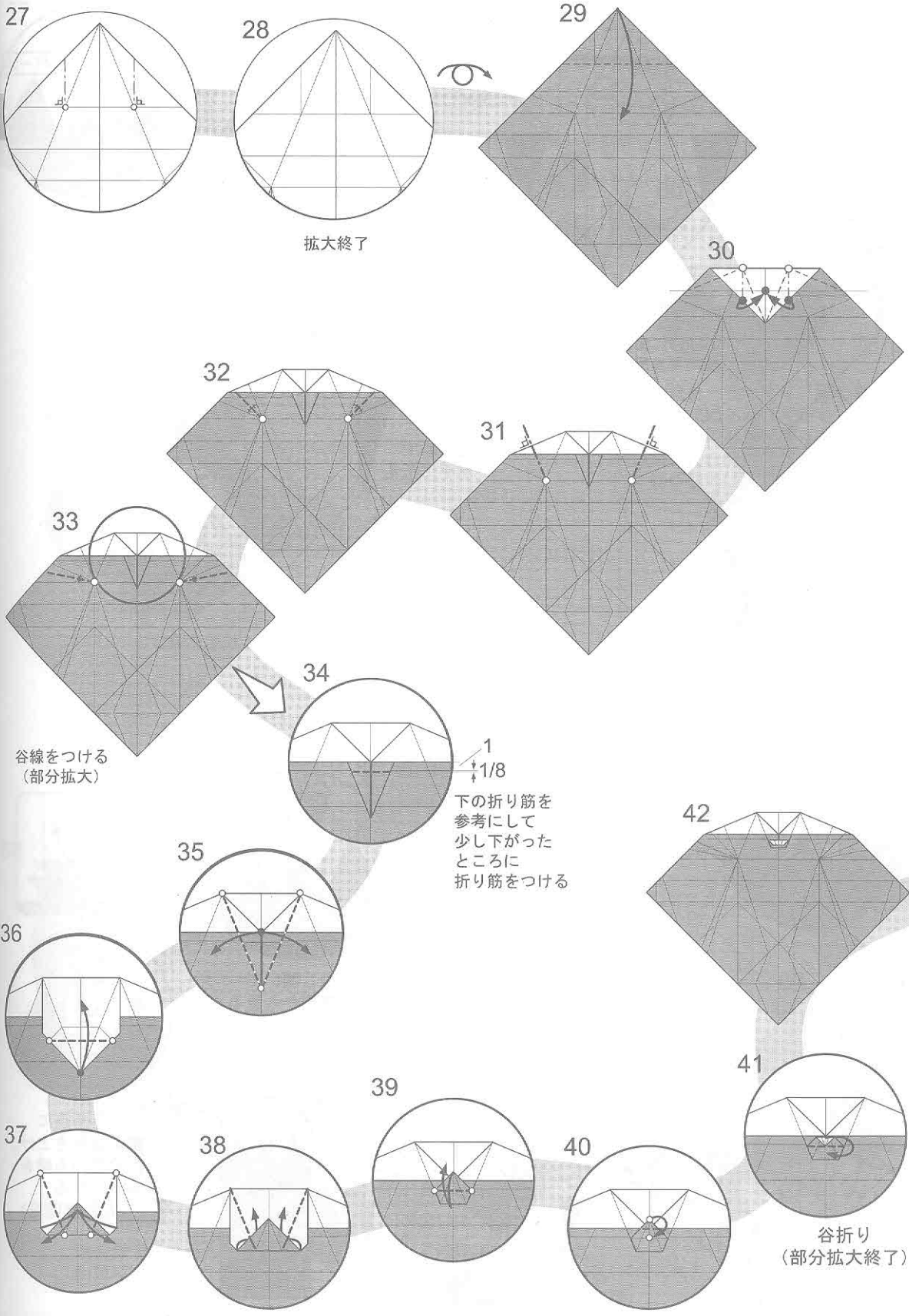

28  
拡大終了

33  
谷線をつける  
(部分拡大)

34  
1  
1/8  
下の折り筋を  
参考にして  
少し下がった  
ところに  
折り筋をつける

41  
谷折り  
(部分拡大終了)

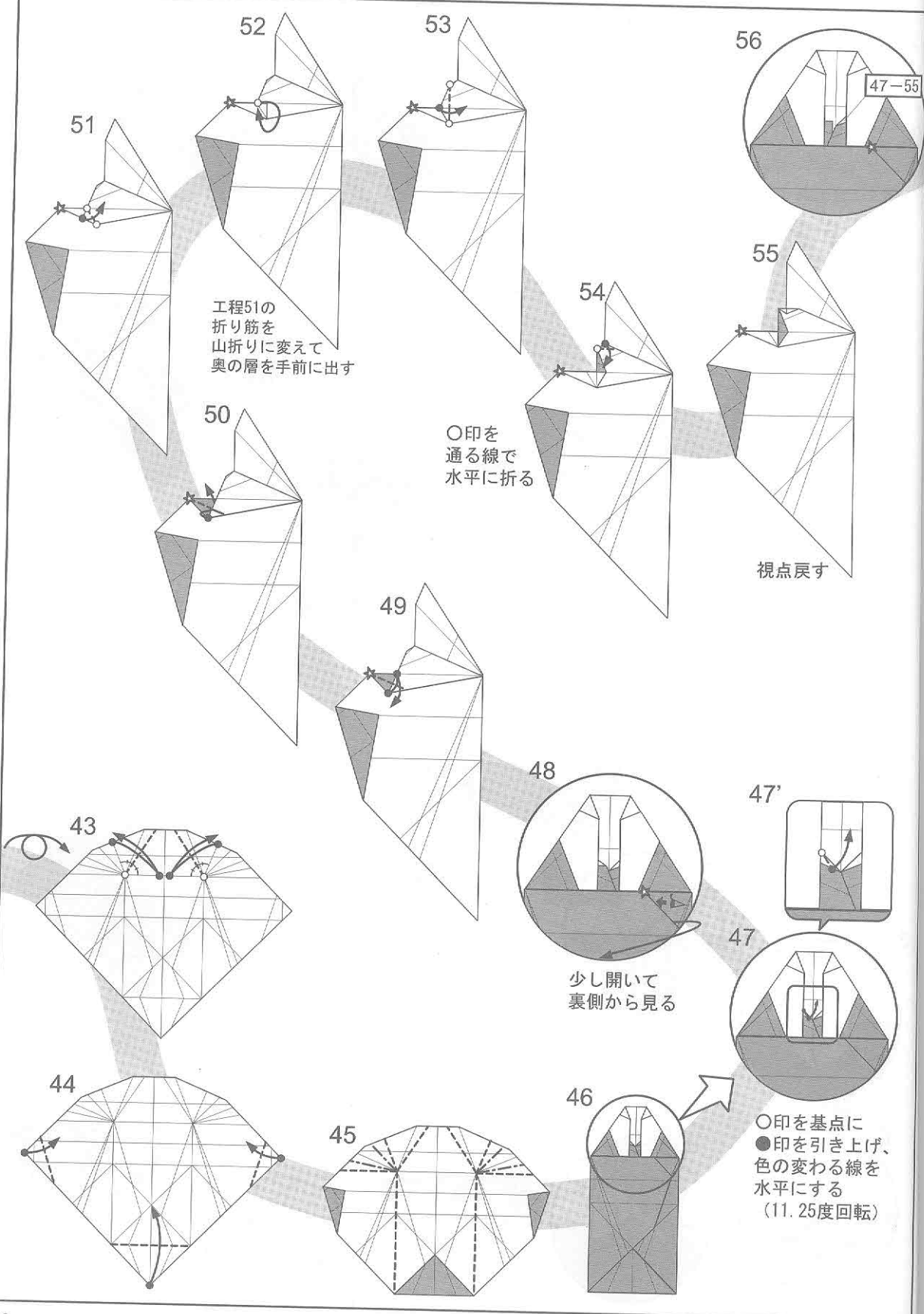

工程51の  
折り筋を  
山折りに変えて  
奥の層を手前に出す

○印を  
通る線で  
水平に折る

視点戻す

少し開いて  
裏側から見る

○印を基点に  
●印を引き上げ、  
色の変わる線を  
水平にする  
(11.25度回転)

47-55

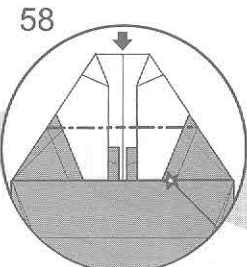
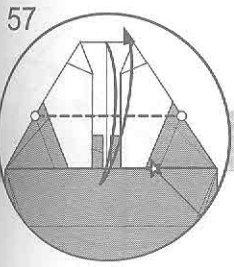

OPEN SINK  
(工程56の層の  
下へ沈め、工程  
41の裏側の層は  
起こす)

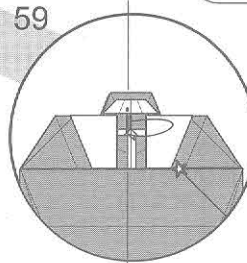

下の縦線に  
あわせて山折り

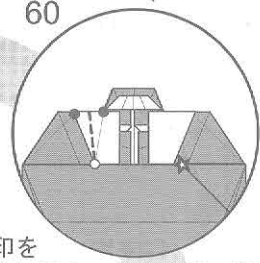
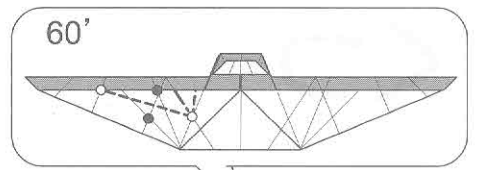

○印を  
基点に紙を一枚めくり、紙の縁を  
右側の●印にあわせて折る  
但し、上辺の部分が引っかかるので、  
少し開いた状態の工程図60'にある  
折り筋を参考に折って畳むとよい

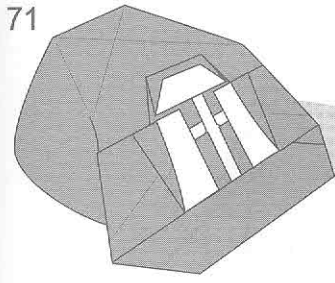

できあがり

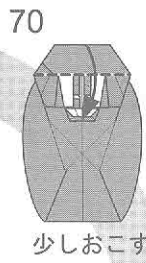

少しおこす

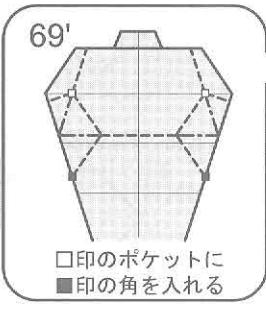
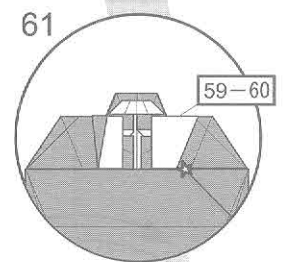

□印のポケットに  
■印の角を入れる

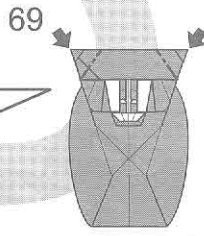

OPEN SINK  
(内部の折り線は  
工程図69'を参照)

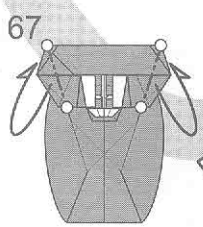
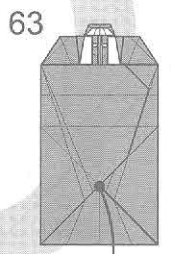
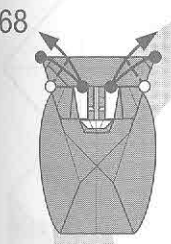
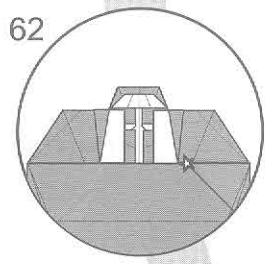

下の層を巻き込んで  
山折り

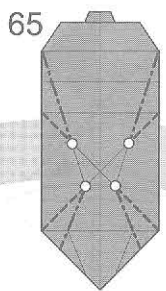
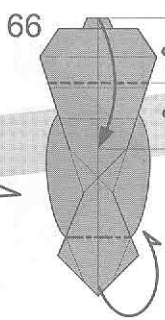

○印を紙面上側凸に  
するように引き寄せる  
(ここから立体的な工程)

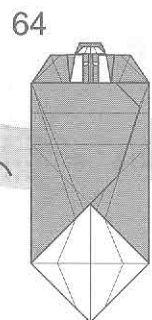

# くつ

創作・作 図 西川 誠司  
Shoues by Seiji Nishikawa  
Diagram: 2013.06.  
Create:2012.10.

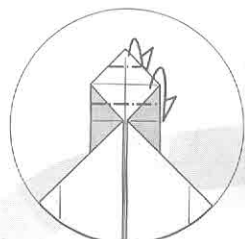

9) やまおり

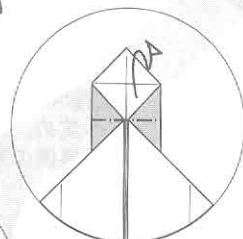
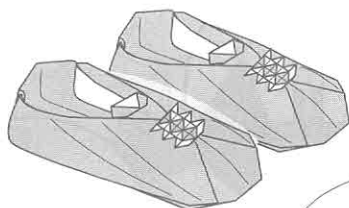

8) おりすじをつける

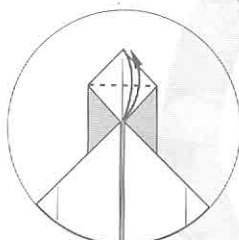

7) おりすじをつける

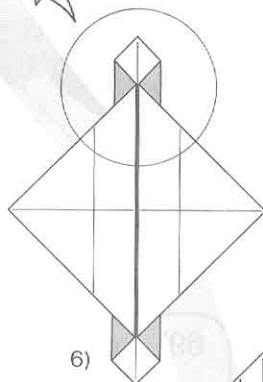
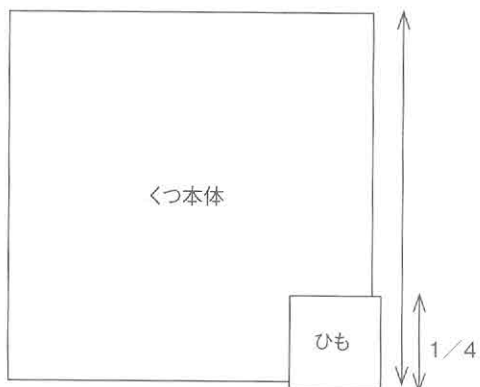

6)

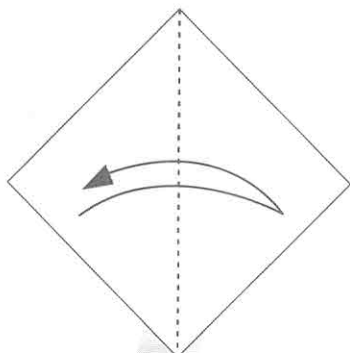

1) おりすじをつける

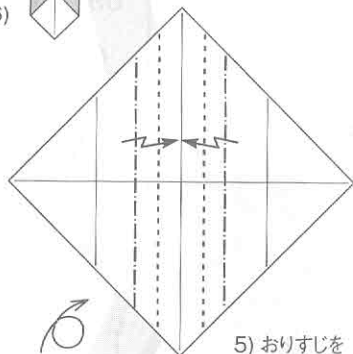

5) おりすじをつける

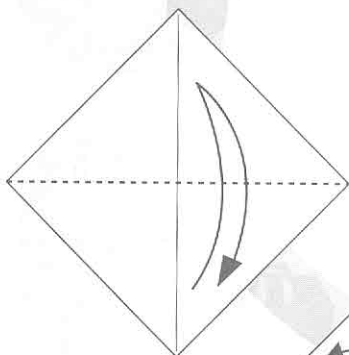

2) おりすじをつける

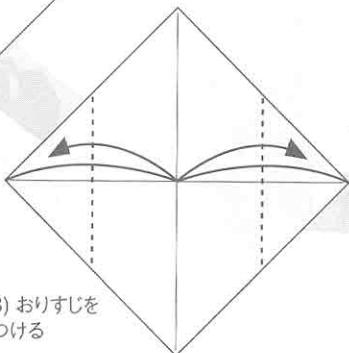

3) おりすじを  
つける

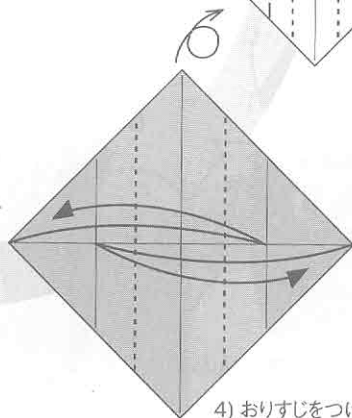

4) おりすじをつける

© SEIJI NISHIKAWA

It is prohibited hard to improve the diagram on the web without permission.

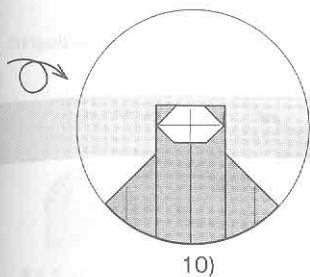

10)

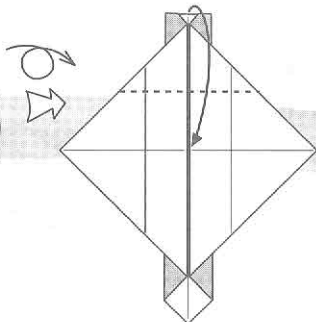

11) 谷折り  
次の図を参照  
(重要!)

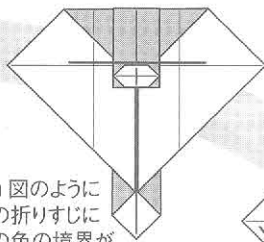

12) 図のように  
下の折りすじに  
上の色の境界が  
沿うように

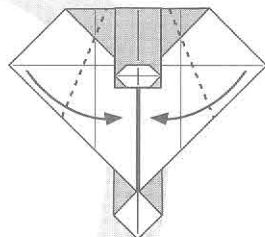

13) 中央に合わ  
せる

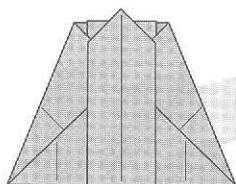

16)13 までもどす

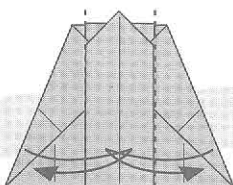

15) 段差に沿うように  
しっかりおりすじを  
つける

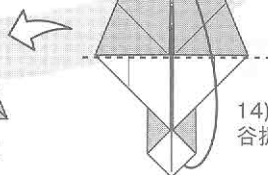

14) 色の境界で  
谷折り

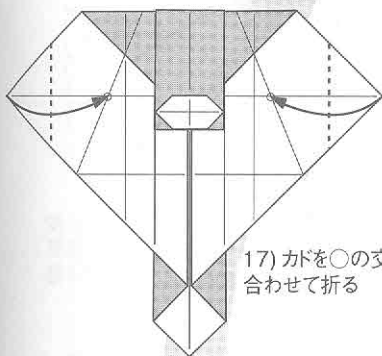

17) カドを○の交点に  
合わせて折る

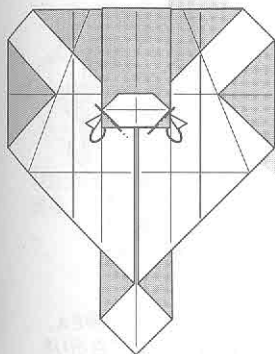

18) 小さいカドを  
中割折り

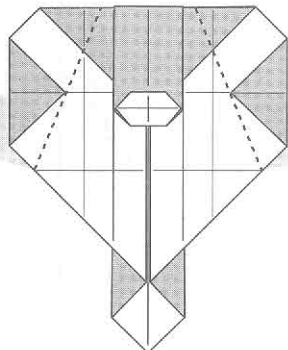

19) ついている折り  
すじで谷折り

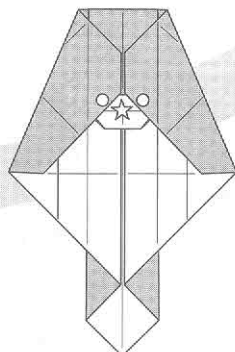

20) ○と☆の重なり  
を入れ替える

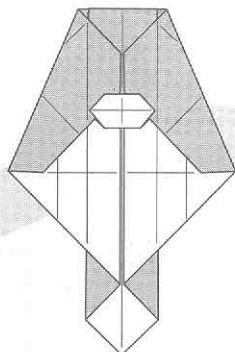

21) 裏返す



© SEIJI NISHIKAWA

It is prohibited hard to improve the diagram on the web without permission.

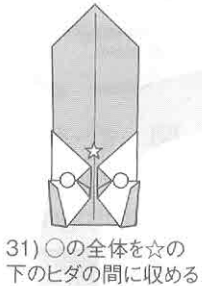

31) ○の全体を☆の下のヒダの間に収める

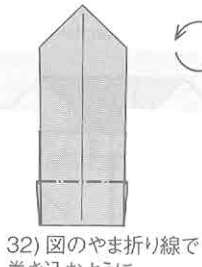

32) 図のやま折り線で巻き込むように

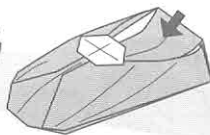

33) しっかり押し込んで形を整える

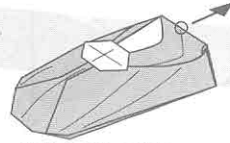

34) ○の後ろを後ろへやや尖らせるように

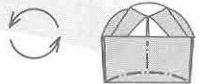

35) 踵のところを丸みをつけて

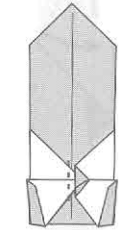

30) 反対側も同様に

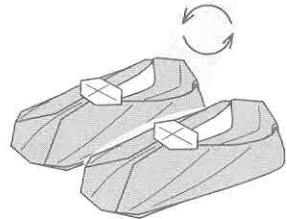

36) 紐なしバージョン出来上がり

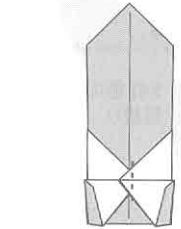

29) 中心のところを少し折り返す

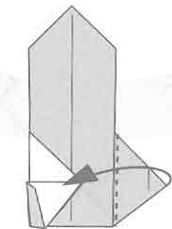

28) 27 を後ろから見たところ。反対側も同様に

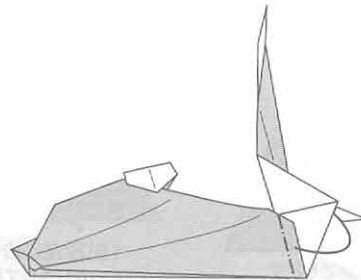

27) 立体のまま飛び出した部分を後ろに折る

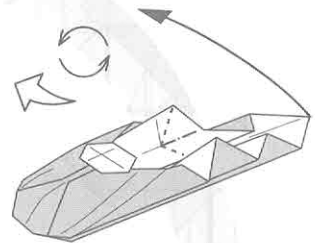

26) 図の山谷線で折り後ろのカドを立体的に立てる

23) カドを中割り折り。左右対称にしても良いが折り加減をわずかに変えて左右のクツに変化を加える。変化をつけ過ぎないことに注意。

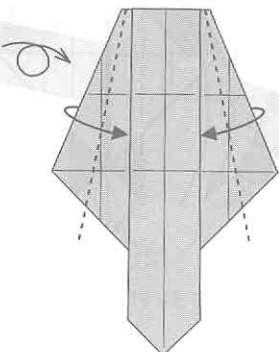

22) 縁をしっかりと段差に合わせるように折る

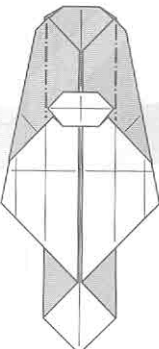
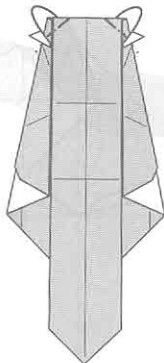

25) ○をしっかり押さえ、中に指を入れて谷折りを90°に立てる

24) おりすじを軽くやま折りに変える

© SEIJI NISHIKAWA

It is prohibited hard to improve the diagram on the web without permission.

ひもパーツ

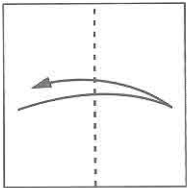

1] おりすじをつける

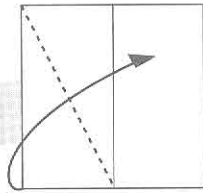

2] カドとおりすじと  
辺の交点を結ぶ線で  
折る

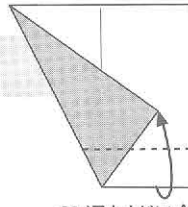

3] 辺をカドに合わせ  
るように折る

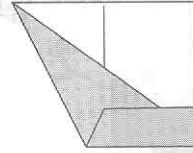

4] 正方形まで戻す

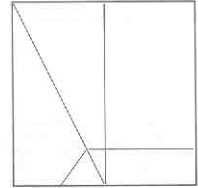

5] 出来た 1/5 の  
おりすじを使って正方形を  
縦横 10等分にする

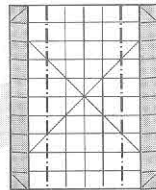

7] 左右を中央に  
合わせるように  
山折り

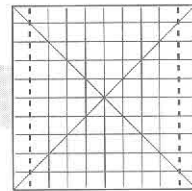

6] 端を一段谷折り

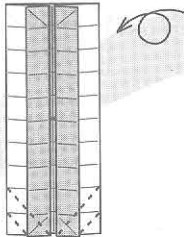

8] 谷折り線で  
巻くように折る

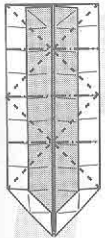

9] 山谷線に従って  
風船の基本形を二つ  
折る要領で

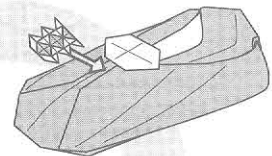
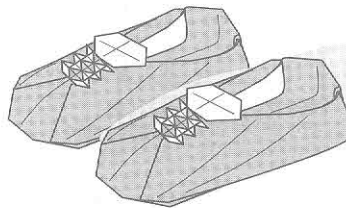

ひもパーツを  
糊で前に貼る

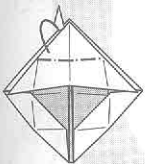

10] カドを後ろに  
折る

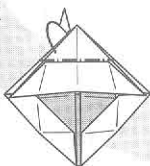

11] もう一つの  
カドも後ろに折る

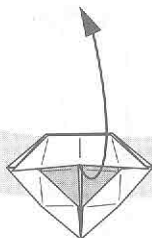

12] 内側をいっば  
いまで広げる

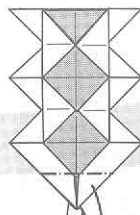

13] カドを後ろに折る

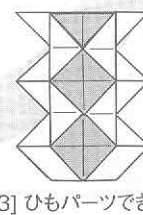

13] ひもパーツできあがり

# ネクタイ付き Yシャツ

創作：2012. 4

創作・折り図： 稲吉秀尚

Model & Diagrams by Hidehisa Inayoshi

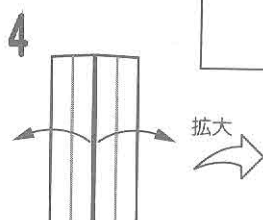
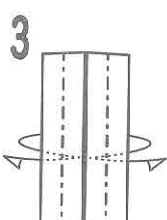
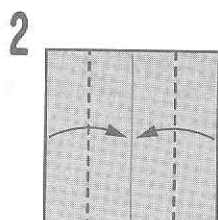
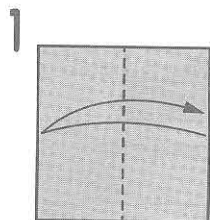
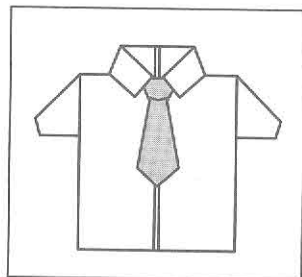

山折りで折りすじをつける

開く

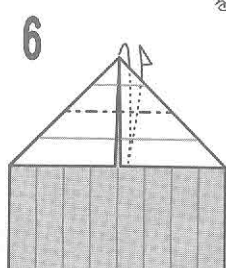
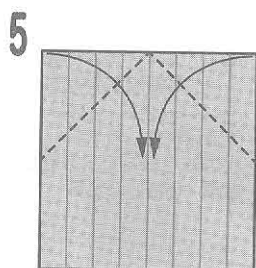

山折りで折りすじをつける

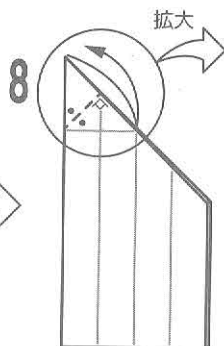
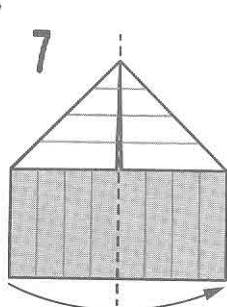

次の図は○内を拡大

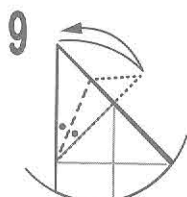

折りすじをつける

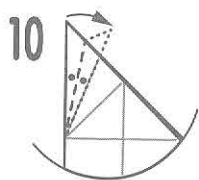

強めに谷折り

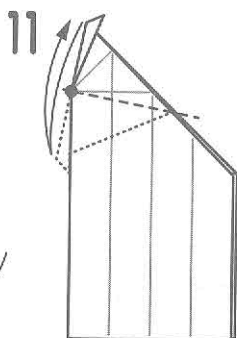

●を支点として、しっかりと折りすじをつけた後、完全に開く

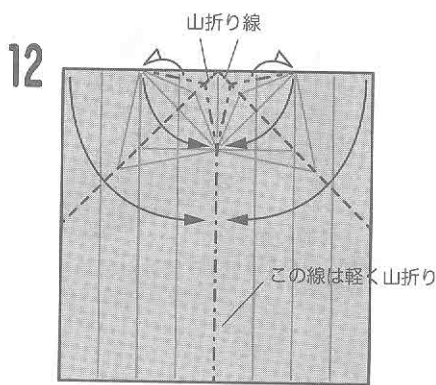

山折り線

この線は軽く山折り

ついている折りすじを利用して「山折り」→「谷折り」の順に折りたたむ (立体的になる)

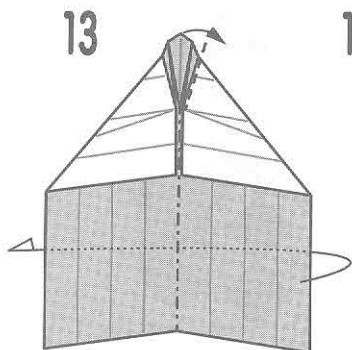

さらに図のように折って平面にする

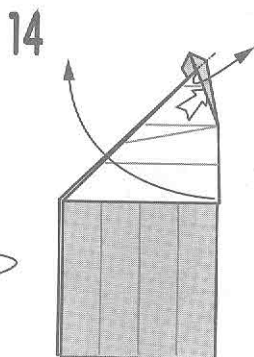

図のように折って上の紙を開く

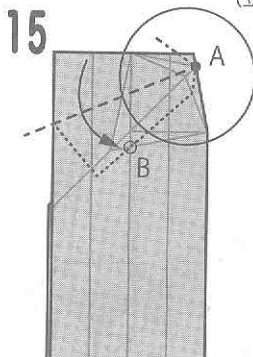

●(A点)を支点として、上のフチが○(B点)を通るように折る(次の図も参考に)

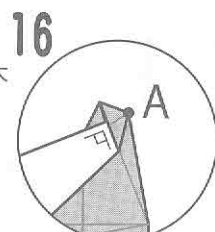

15のA点付近はつられて上がってくるので、図のように処理をする

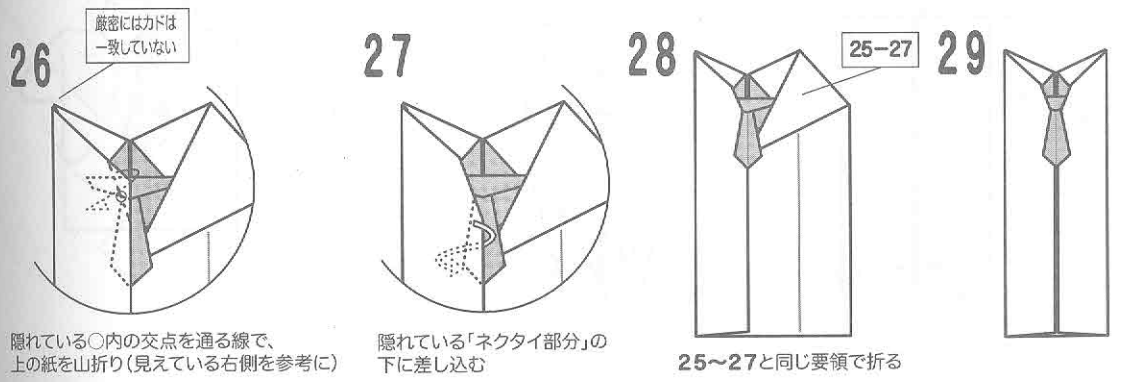
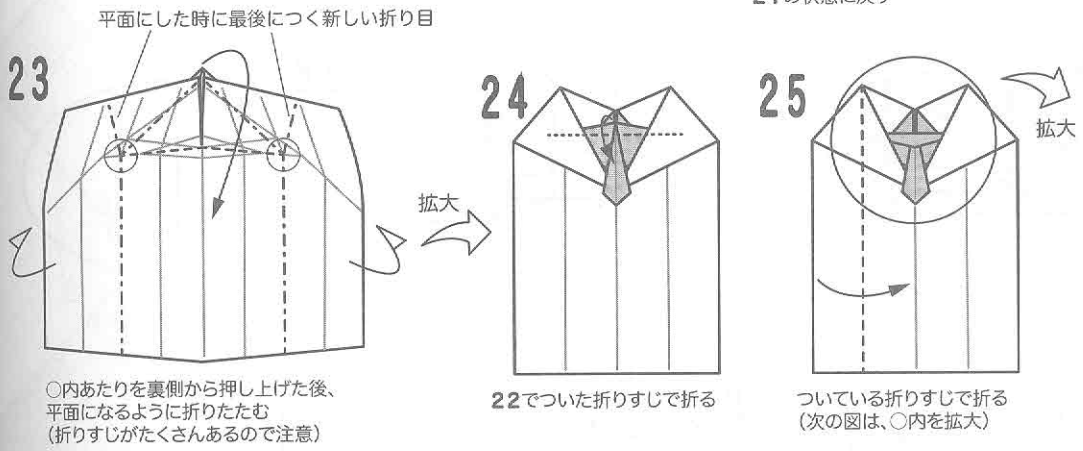
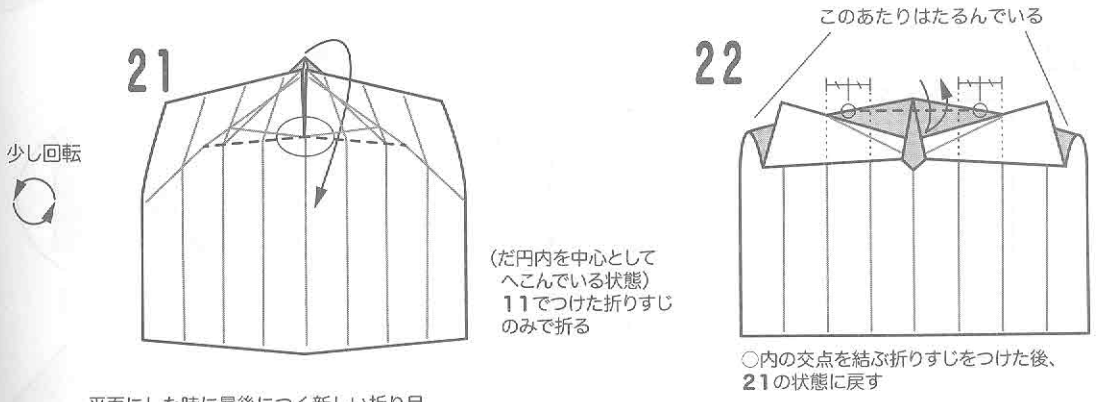
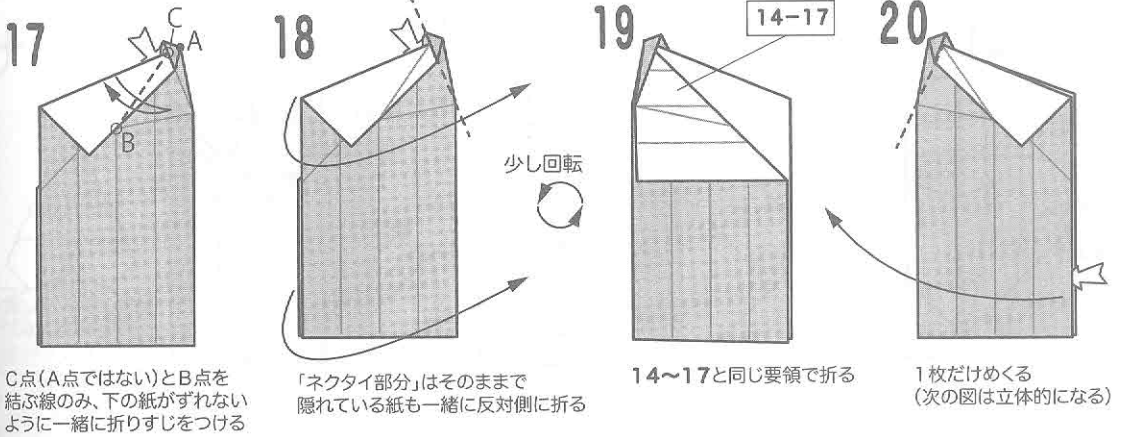

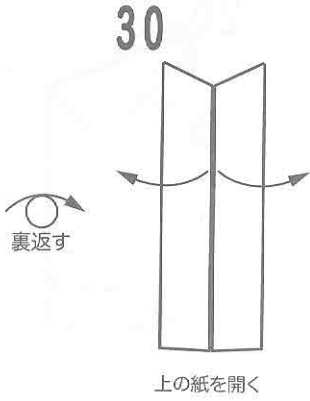

上の紙を開く

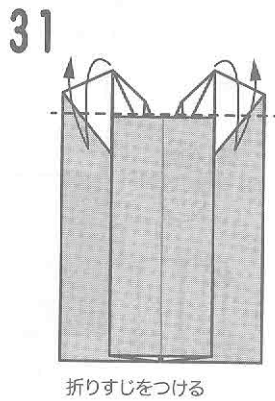

折りすじをつける

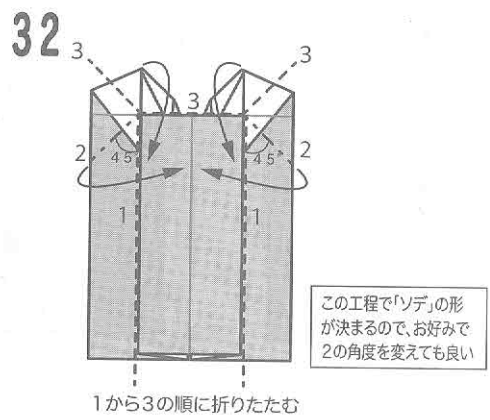

1から3の順に折りたたむ

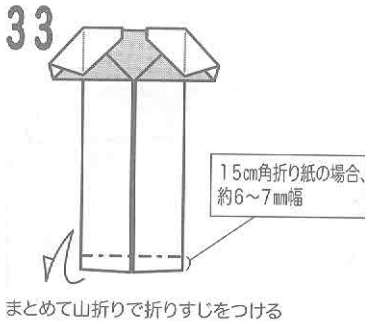

まとめて山折りで折りすじをつける

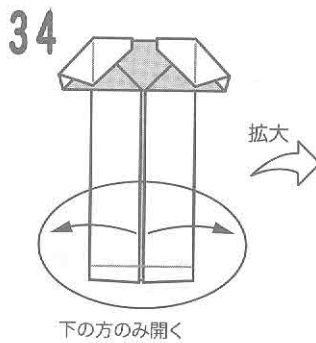

下方のみ開く

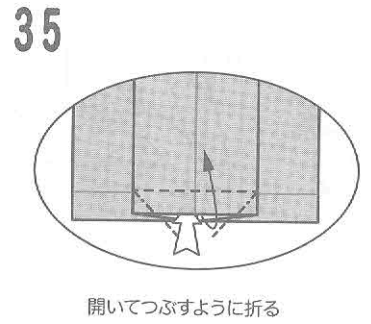

開いてつぶすように折る

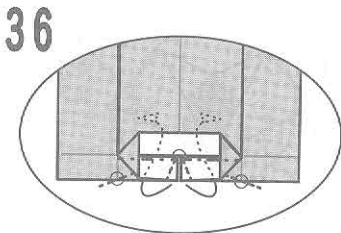

変則的な中わり折りをする(隠れている下の紙は、○を通る斜めの線で折る)

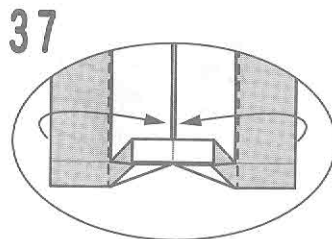

閉じる

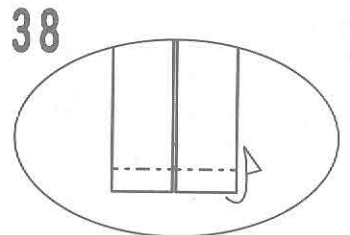

ついている折りすじで折る

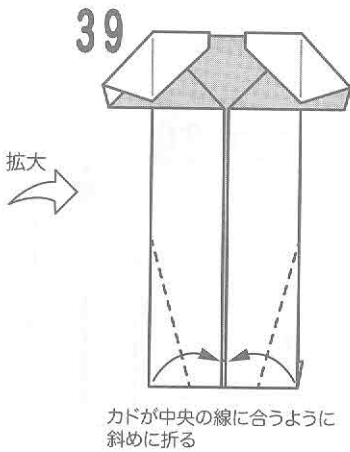

カドが中央の線に合うように斜めに折る

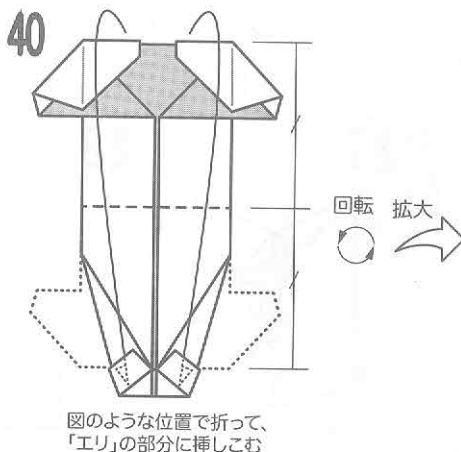

図のような位置で折って、「エリ」の部分に押しこむ

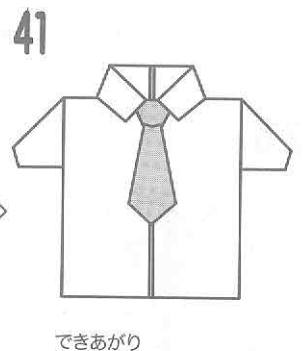

できあがり

# サンタクロース

創作 2012/12/20  
作図 2013/05/19  
山口 之彦

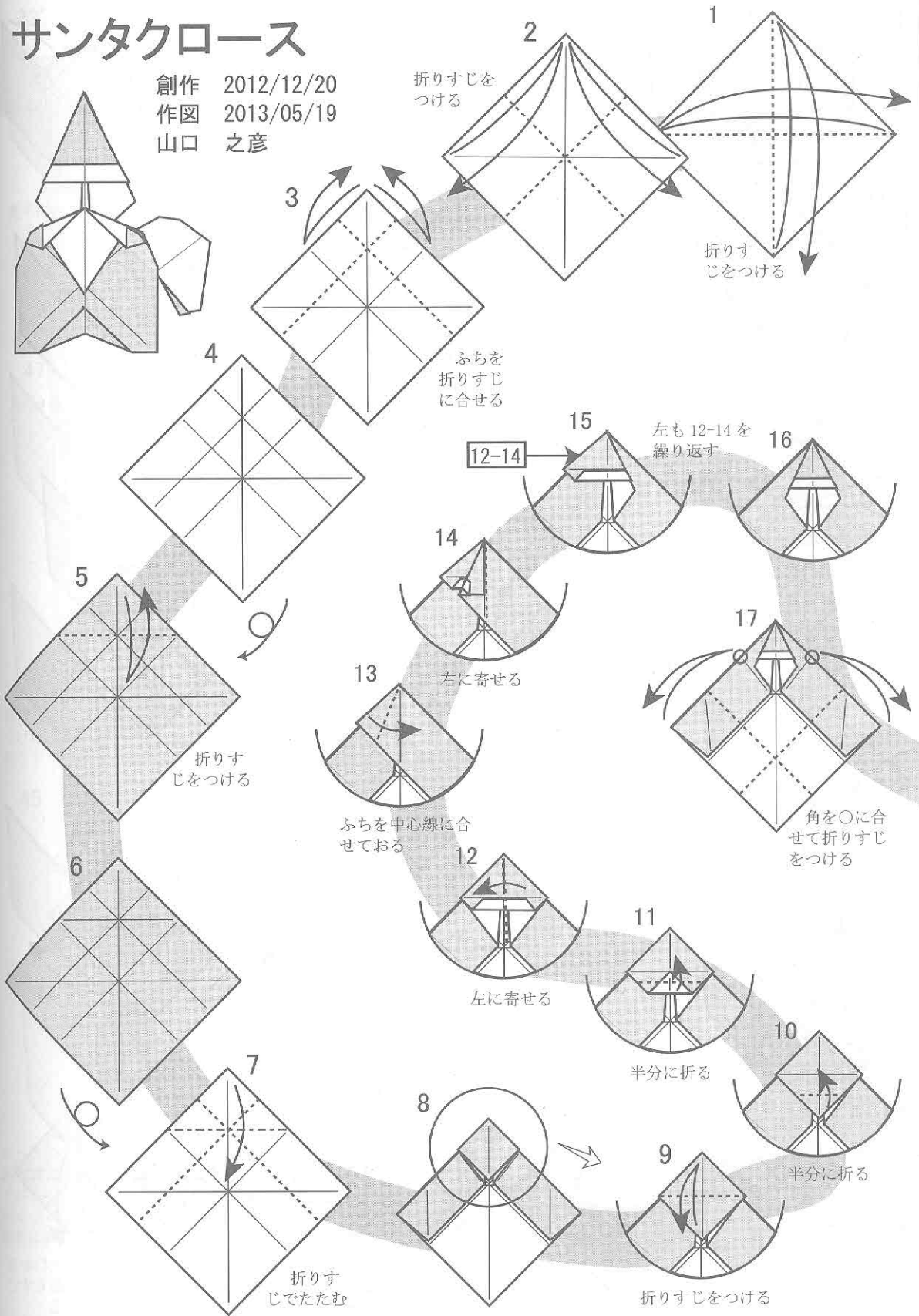
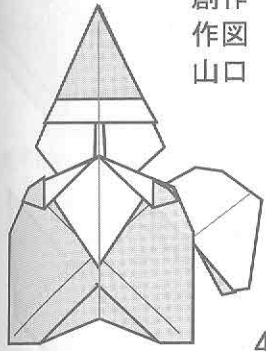

折りすじをつける

折りすじをつける

ふちを折りすじに合せる

左も 12-14 を繰り返す

12-14

右に寄せる

折りすじをつける

ふちを中心線に合せておく

角を○に合わせて折りすじをつける

左に寄せる

半分に折る

半分に折る

折りすじでたたむ

折りすじをつける

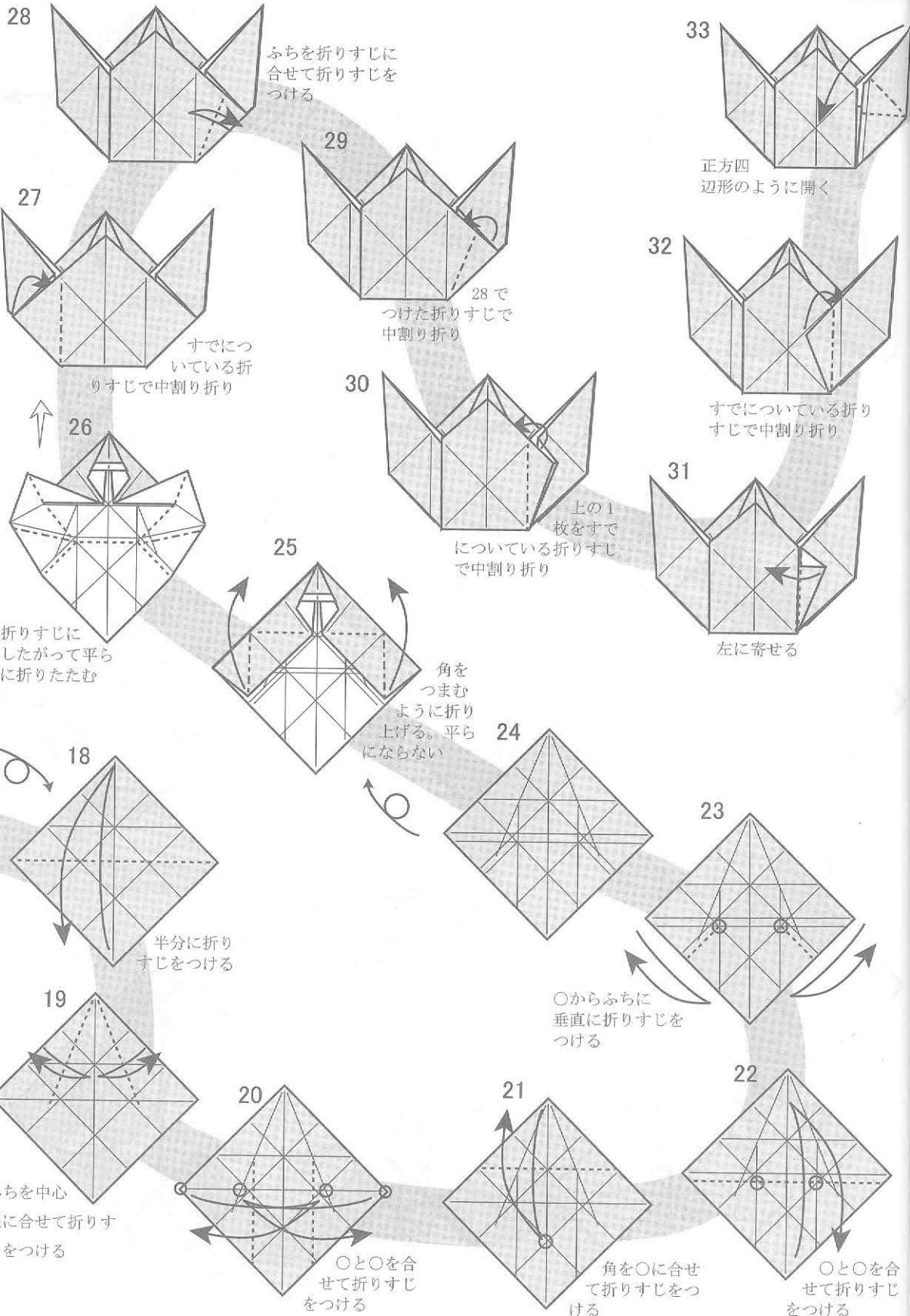

33' (途中図)

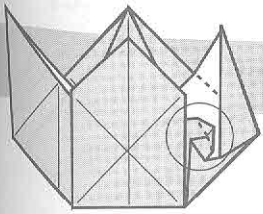

裏(円内)は平らにたたむ

34

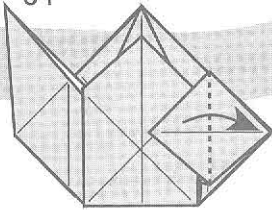

右に半分に折る

35

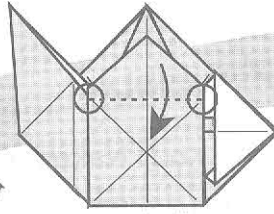

○を結ぶ線で折る

36

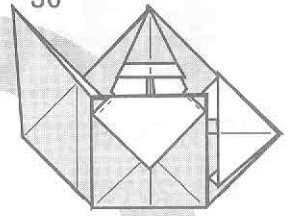

角の三角に沿って折りすじをつける

48

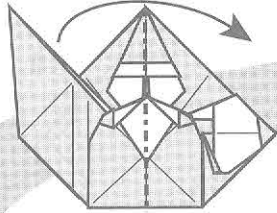

半分に折る

49

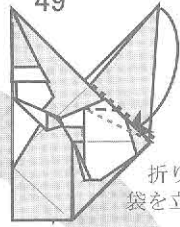

折りすじで袋を立てる

37

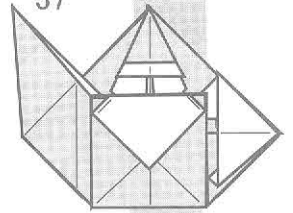

上に折りあげる

47

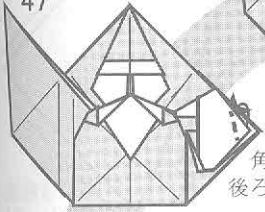

角を少し後ろに折る

50

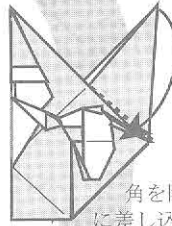

角を隙間に差し込む

38

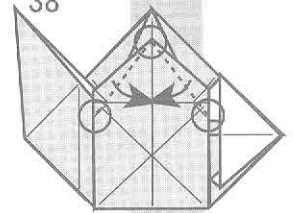

○を結ぶ線で折る

46

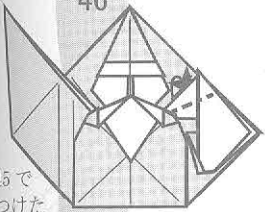

45でつけた折りすじでうしろに折る

53

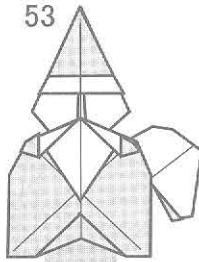

できあがり

51

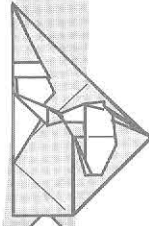

下から指を入れ折りすじで立体にする

39

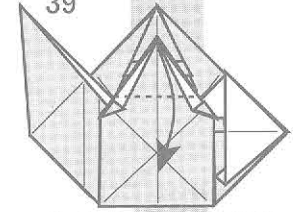

すでにある折りすじで折る

45

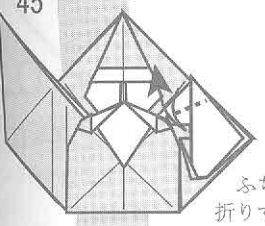

ふちをふちに合せて折りすじをつける

52

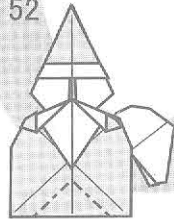

図を参考に中割り折りのように折る

40

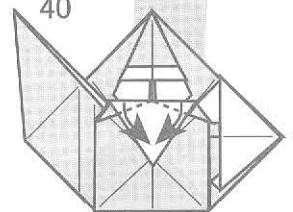

ふちにそって折る

44

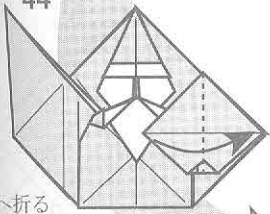

右へ折る  
ふちがつられて上がってくるので45のよにふちを斜めに折る

43

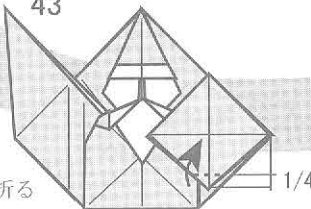

1/4を折る

42

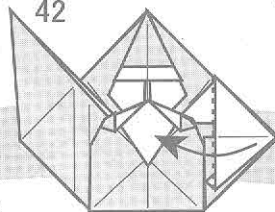

左へ折り返す

41

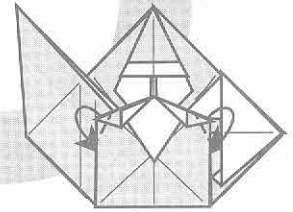

角を少し後ろに折る



# もみじ

Maple Leaf

中川 幸治

Kouji Nakagawa

創作:2010年 6月 作図:2012年 8月

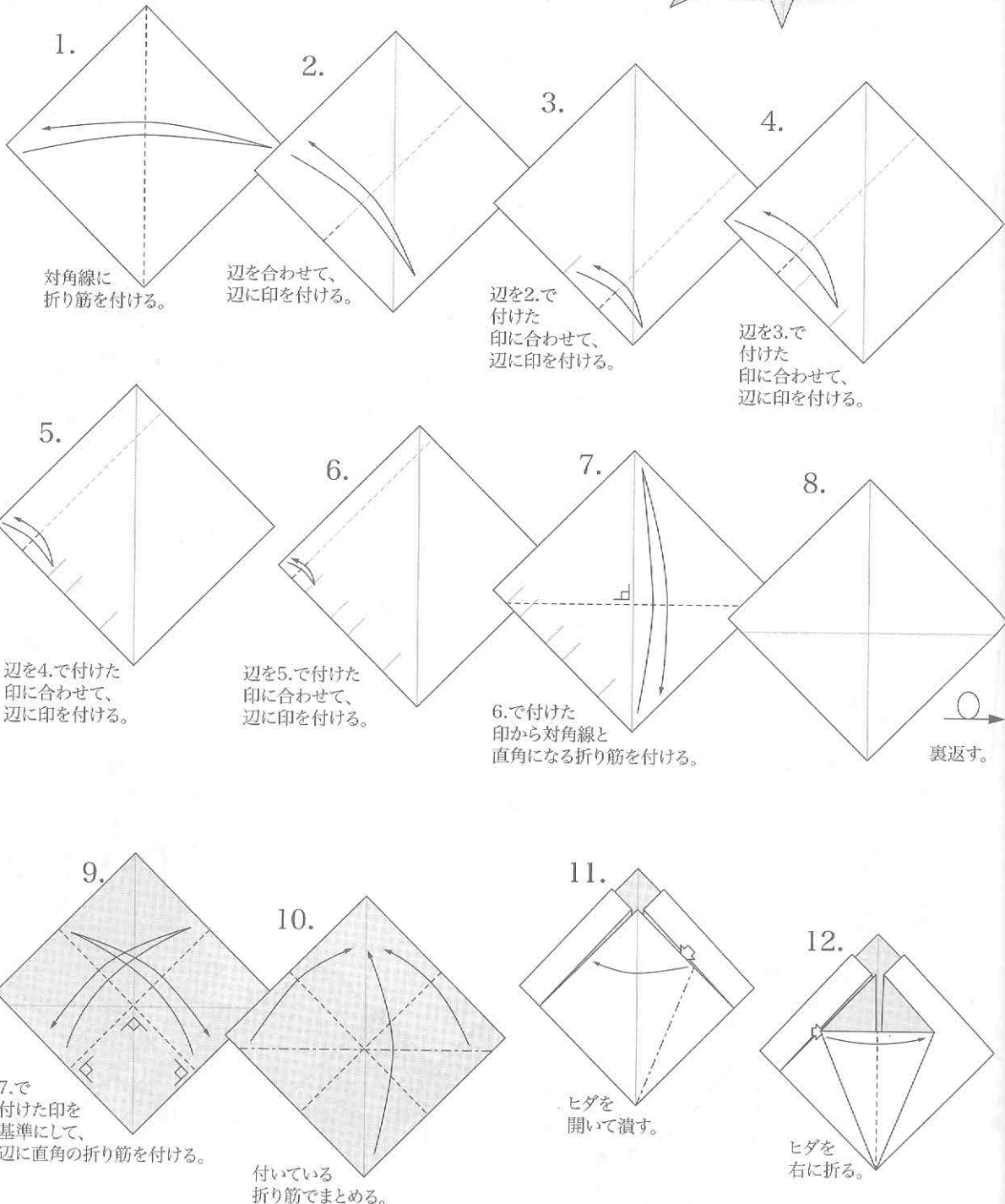
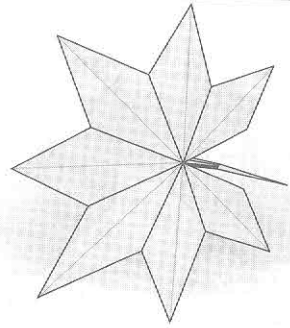

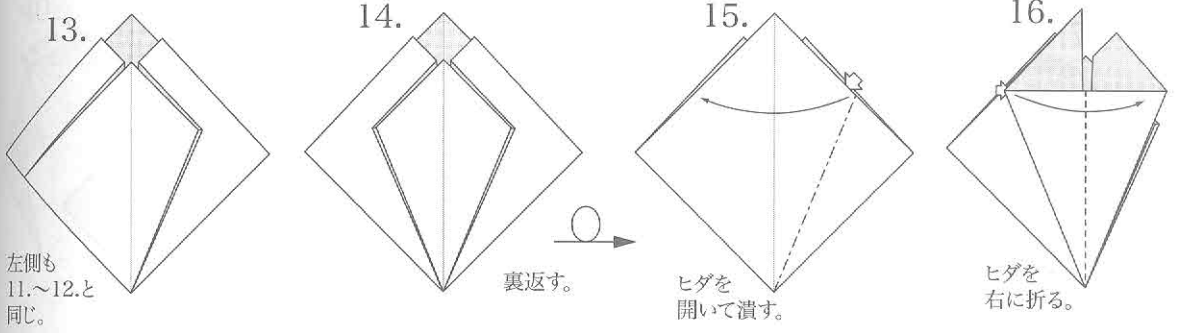

左側も  
11.~12.と  
同じ。

裏返す。

ヒダを  
開いて潰す。

ヒダを  
右に折る。

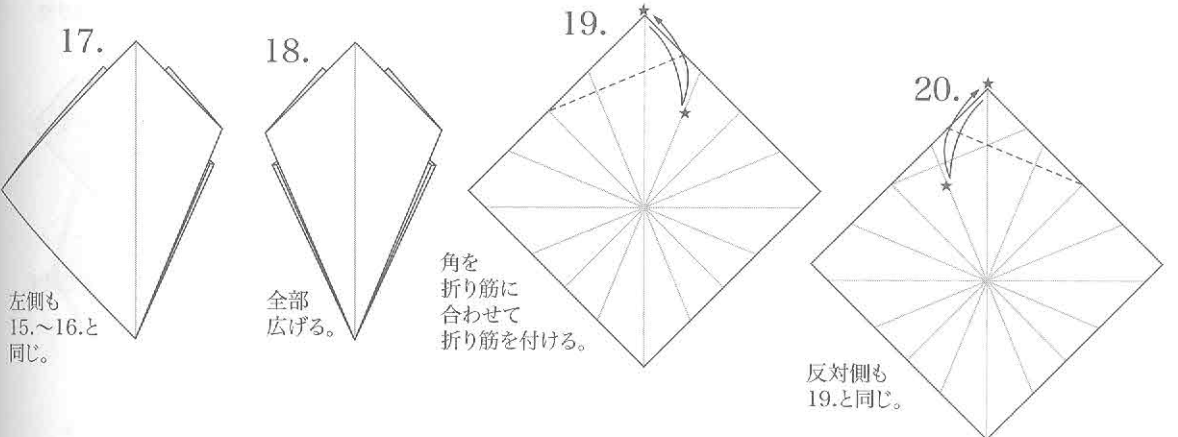

左側も  
15.~16.と  
同じ。

全部  
広げる。

角を  
折り筋に  
合わせて  
折り筋を付ける。

反対側も  
19.と同じ。

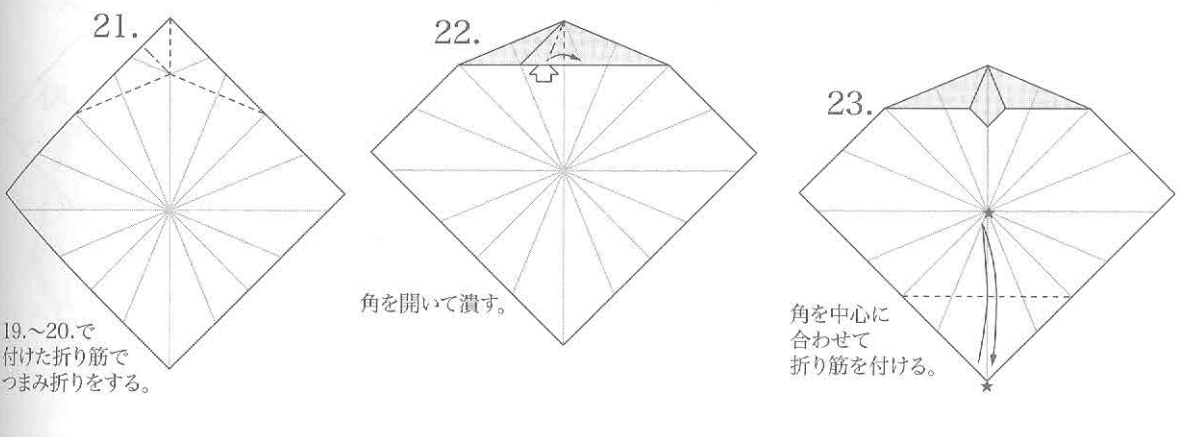

19.~20.で  
付けた折り筋で  
つまみ折りを  
する。

角を開いて潰す。

角を中心に  
合わせて  
折り筋を付ける。

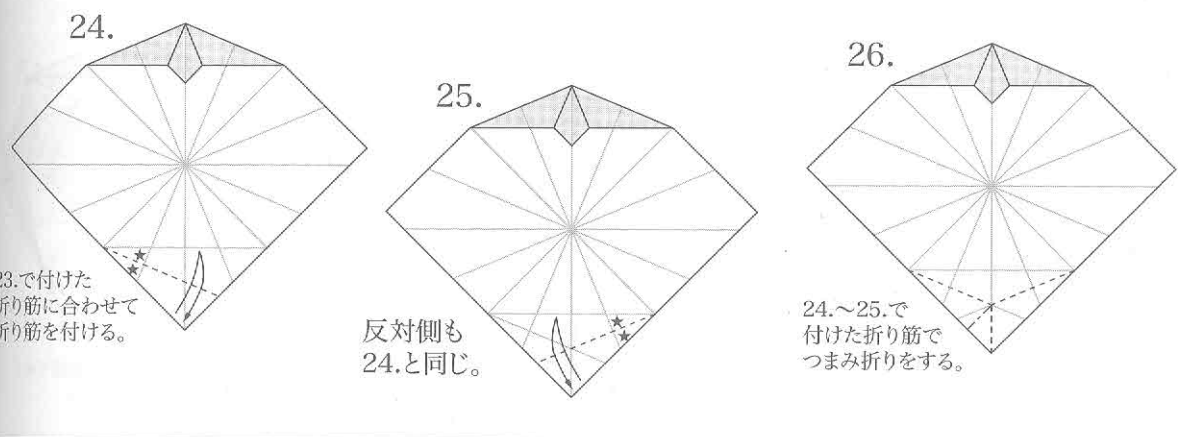

23.で付けた  
折り筋に合わせて  
折り筋を付ける。

反対側も  
24.と同じ。

24.~25.で  
付けた折り筋で  
つまみ折りを  
する。

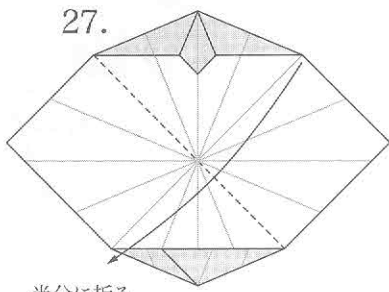

27. 半分に折る。

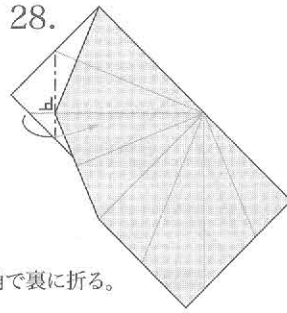

28. 角で裏に折る。

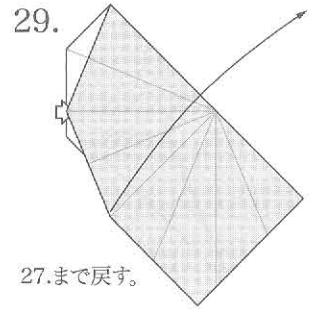

29. 27.まで戻す。

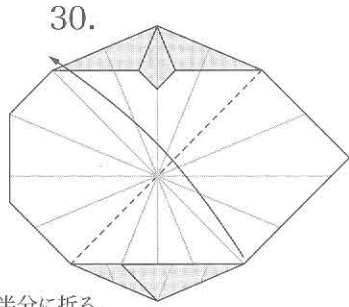

30. 半分に折る。

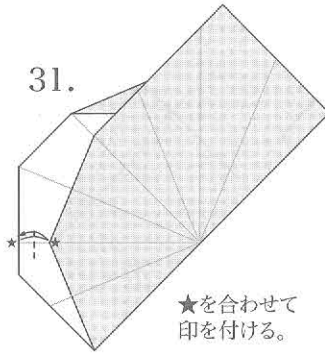

31. ★を合わせて印を付ける。

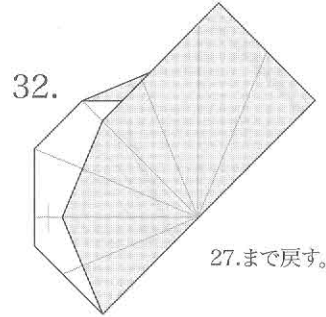

32. 27.まで戻す。

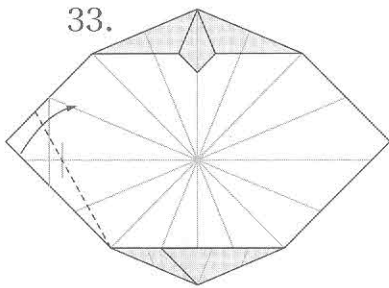

33. 31.で付けた印を通るように折る。

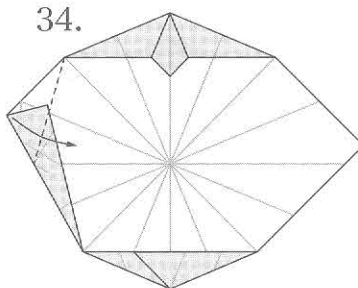

34. 31.で付けた印を通るように折る。

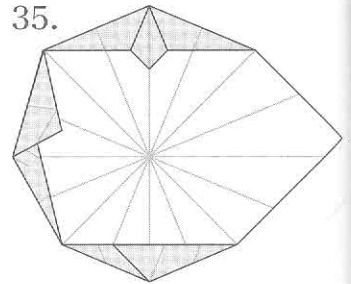

35. 右側も27.~34.と同じ。

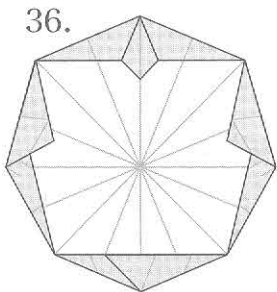

36. 26.でつまみ折りをした部分を広げる。

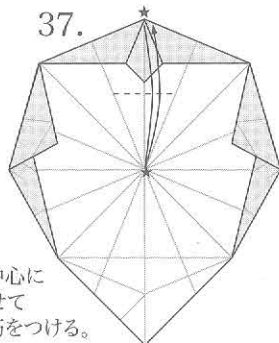

37. 角を中心に合わせて折り筋をつける。

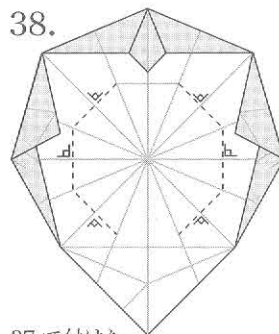

38. 37.で付けた折り筋を基準にして折り筋を付ける。

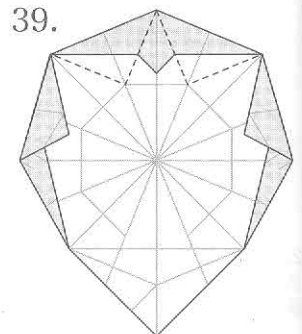

39. 折り筋を付ける。

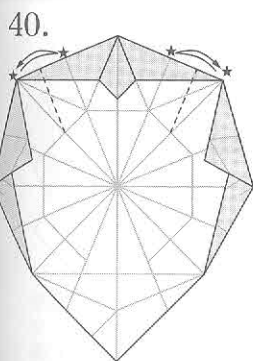

40. 折り筋を付ける。

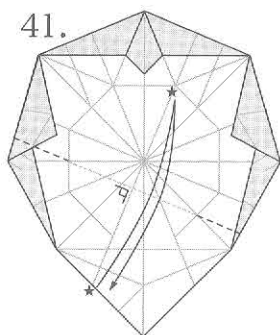

41. 折り筋を付ける。

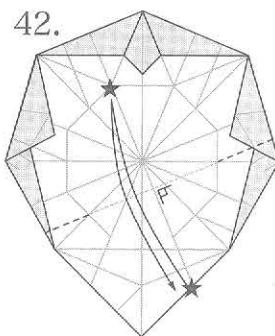

42. 折り筋を付ける。

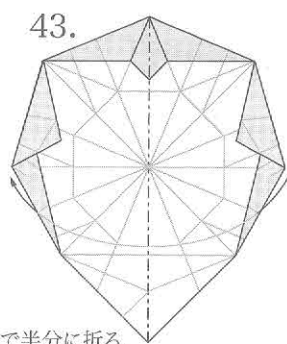

43. 中心で半分に折る。

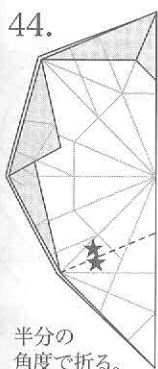

44. 半分の角度で折る。

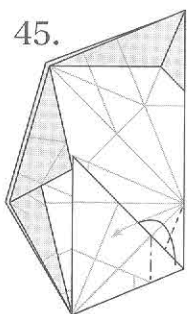

45. 中割り折りをする。

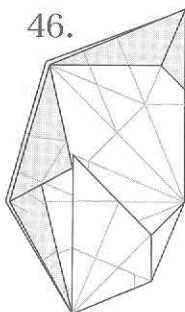

46. 44.まで戻す。

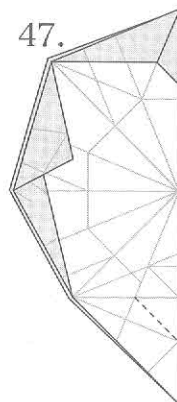

47. 折り筋を付ける。

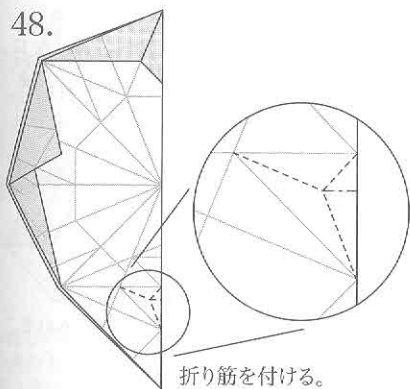

48. 折り筋を付ける。

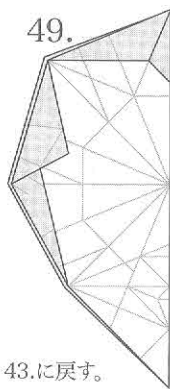

49. 43.に戻す。

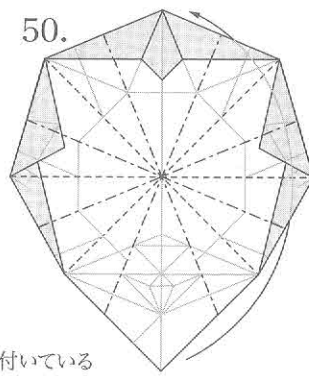

50. 付いている折り筋でたたむ。

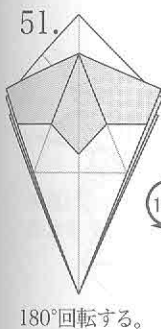

51. 180°回転する。

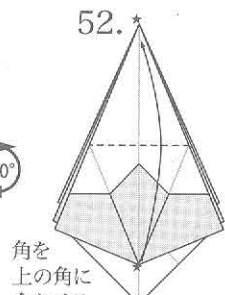

52. 角を上  
の角に  
合わせる。  
中間のヒダが  
起き上がる。

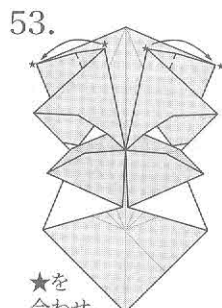

53. ★を  
合わせ、  
付いている折  
り筋で  
平らにする。

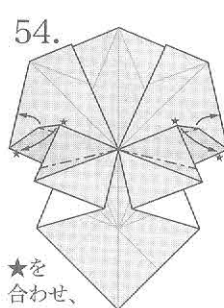

54. ★を  
合わせ、  
平らにする。

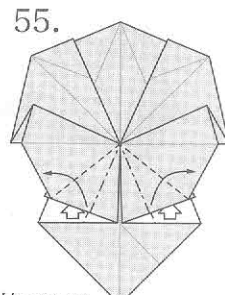

55. 付いて  
いる折  
り筋で  
開いて  
潰す。

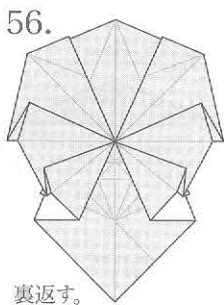

裏返す。

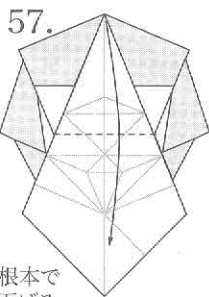

角を根本で  
折り下げる。

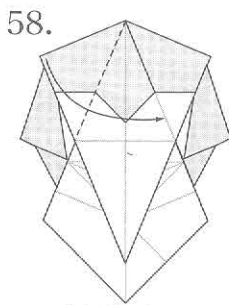

折り筋で折る。

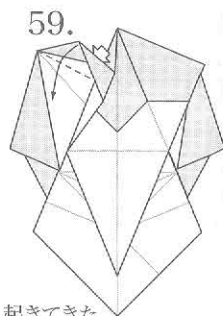

起きてきた  
ヒダを開いて潰す。

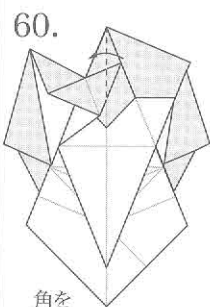

角を  
折り返す。

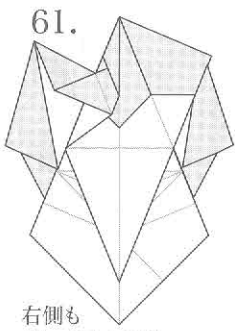

右側も  
58.~61.と同じ。

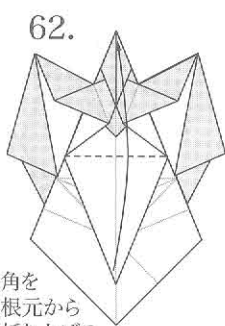

角を  
根元から  
折り上げる。

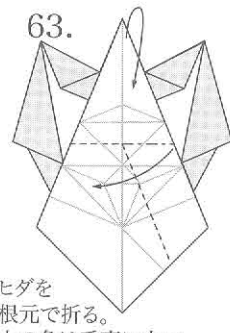

ヒダを  
根元で折る。  
上の角は垂直に立つ。

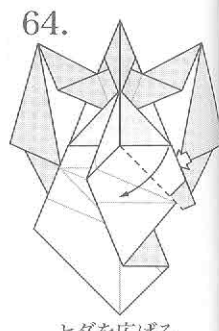

ヒダを広げる。

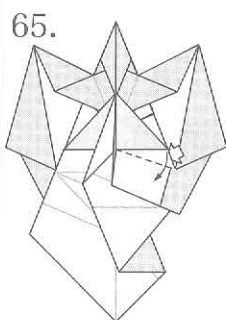

ヒダを広げる。

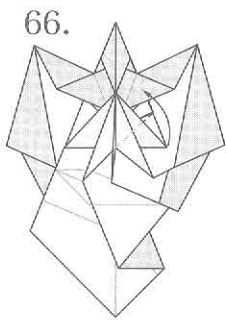

角を折り返す。

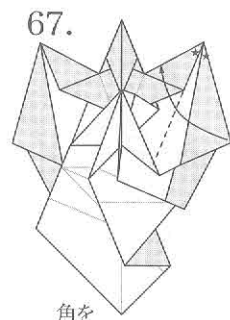

角を  
半分に折る。

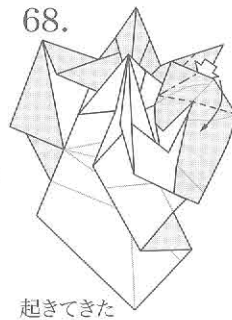

起きてきた  
ヒダを開いて潰す。

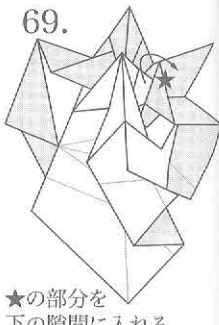

★の部分  
下の隙間に入れる。

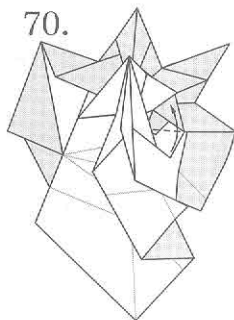

角を折り返す。

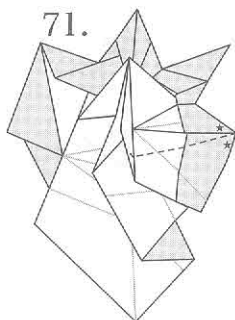

角を半分に折る。

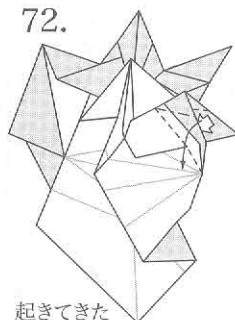

起きてきた  
ヒダを開いて潰す。

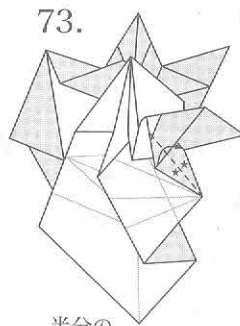

半分の  
角度で折る。

74.

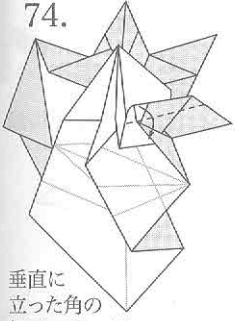

垂直に  
立った角の  
根元の所で折る。

75.

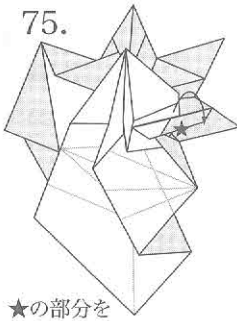

★の部分  
を下の隙間  
に入れる。

76.

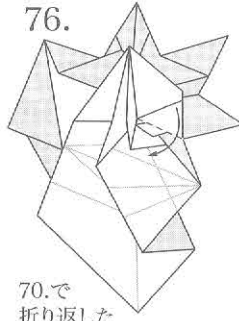

70.で  
折り返した  
角を戻す。

77.

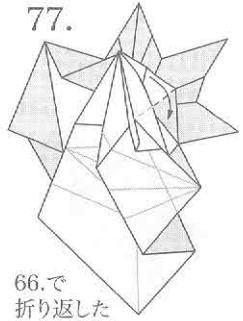

66.で  
折り返した  
角を戻す。

78.

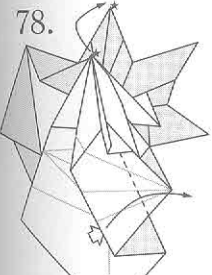

ヒダを  
開くと同時に  
垂直に立っている  
角を上角に合わせる。

79.

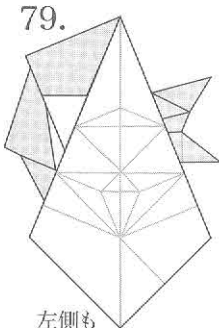

左側も  
63.~78.と同じ。

80.

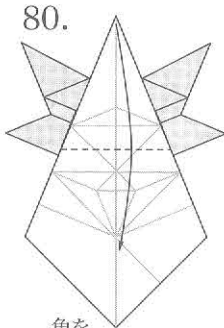

角を  
折り下げる。

81.

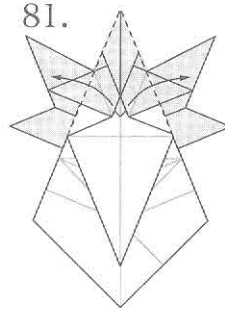

ヒダを外側に開く。

82.

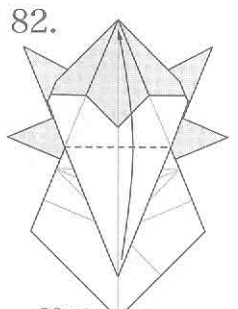

80.で  
折り下げた角を  
元に戻す。

83.

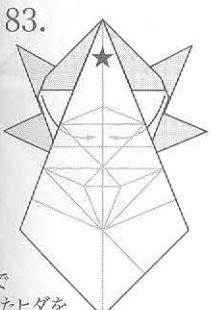

81.で  
開いたヒダを  
★の角の上から2番目の  
隙間に差込み角を固定する。

84.

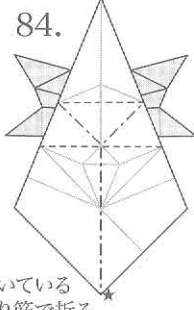

付いている  
折り筋で折る。  
★の角を垂直に立てる。

85.

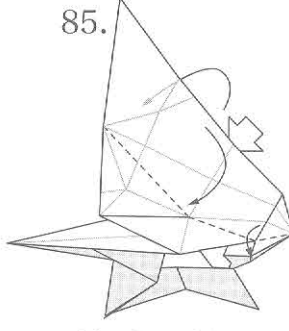

垂直に立った部分  
を軽く開く。

86.

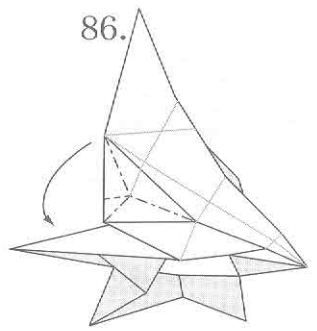

付いている折り筋で  
鶴の基本形に畳む。

87.

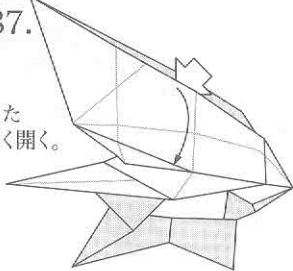

垂直に立った  
部分を大きく開く。

88.

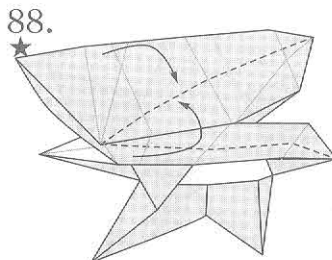

折り筋を使って折る。  
★の角は垂直に立った  
状態のまま。

89.

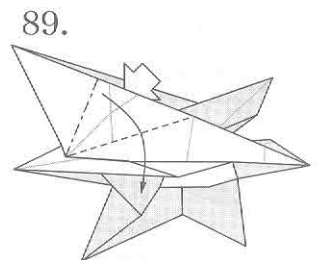

垂直の部分を  
開いて潰す。

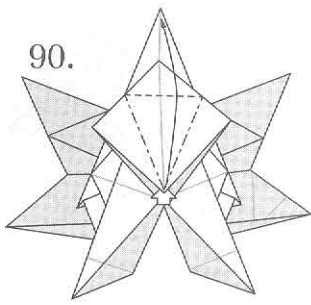

90.

89.で潰した部分で  
鶴の基本形を折る。

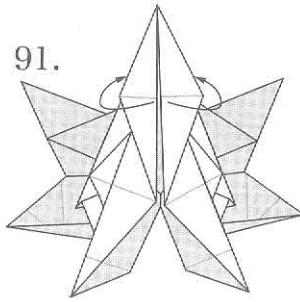

91.

表の紙を引っ張り返す。

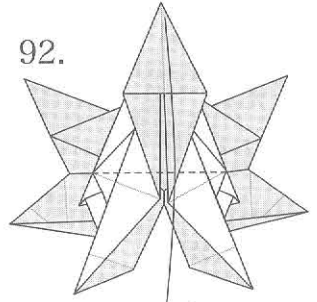

92.

角を根元で  
折り下げる。

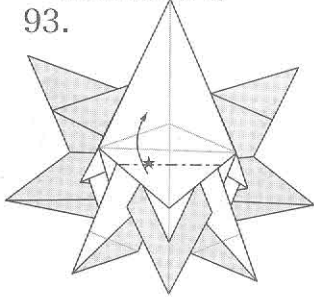

93.

★の角を潰しながら  
上に折り上げる。

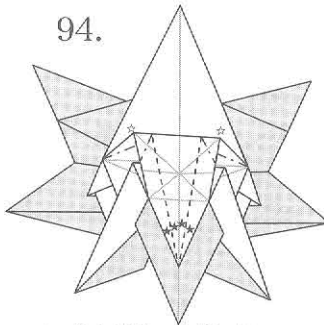

94.

★の角を半分の角度で折る。  
☆の角は平らに潰す。

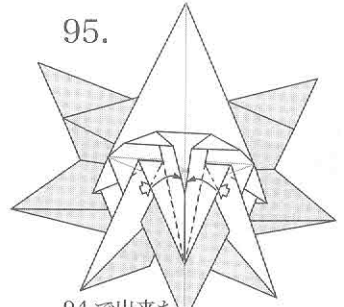

95.

94.で出来た  
縁に沿って開いて潰す。

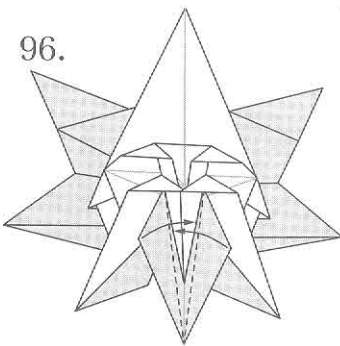

96.

角を細くする。

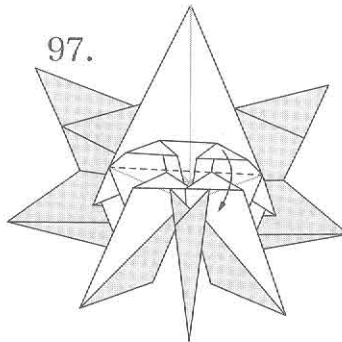

97.

中央の角を  
下に折り下げる。

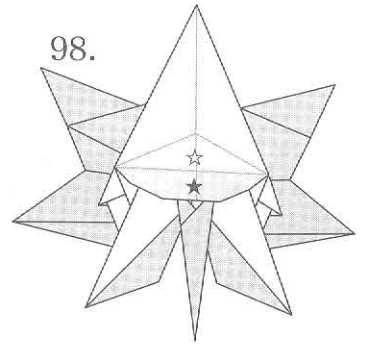

98.

★の角をClose sink で  
☆の下に押し込む。

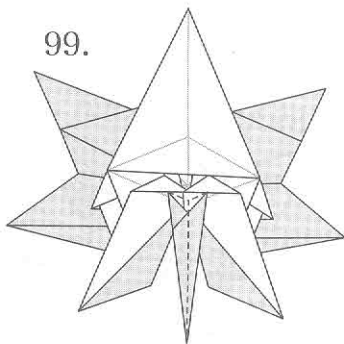

99.

角を摘んで立てつつ  
細くする。

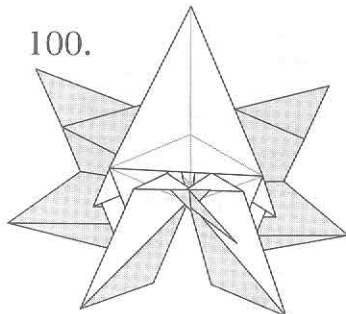

100.

裏返す。

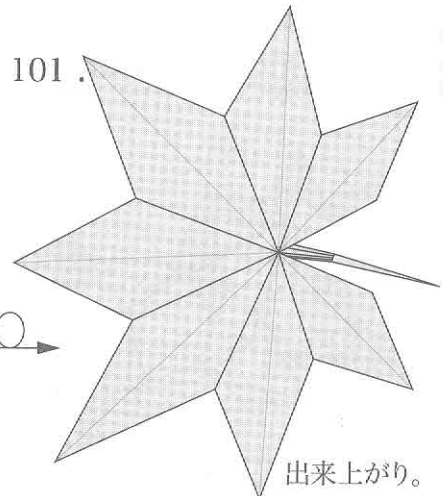

101.

出来上がり。

# トビハゼ

mudskipper by Hiroo Kamo

作・図 加茂弘郎

創作 / 2013.1.26 作図 / 2013.6.23

※ 紙のうら面を手前にして折り始める

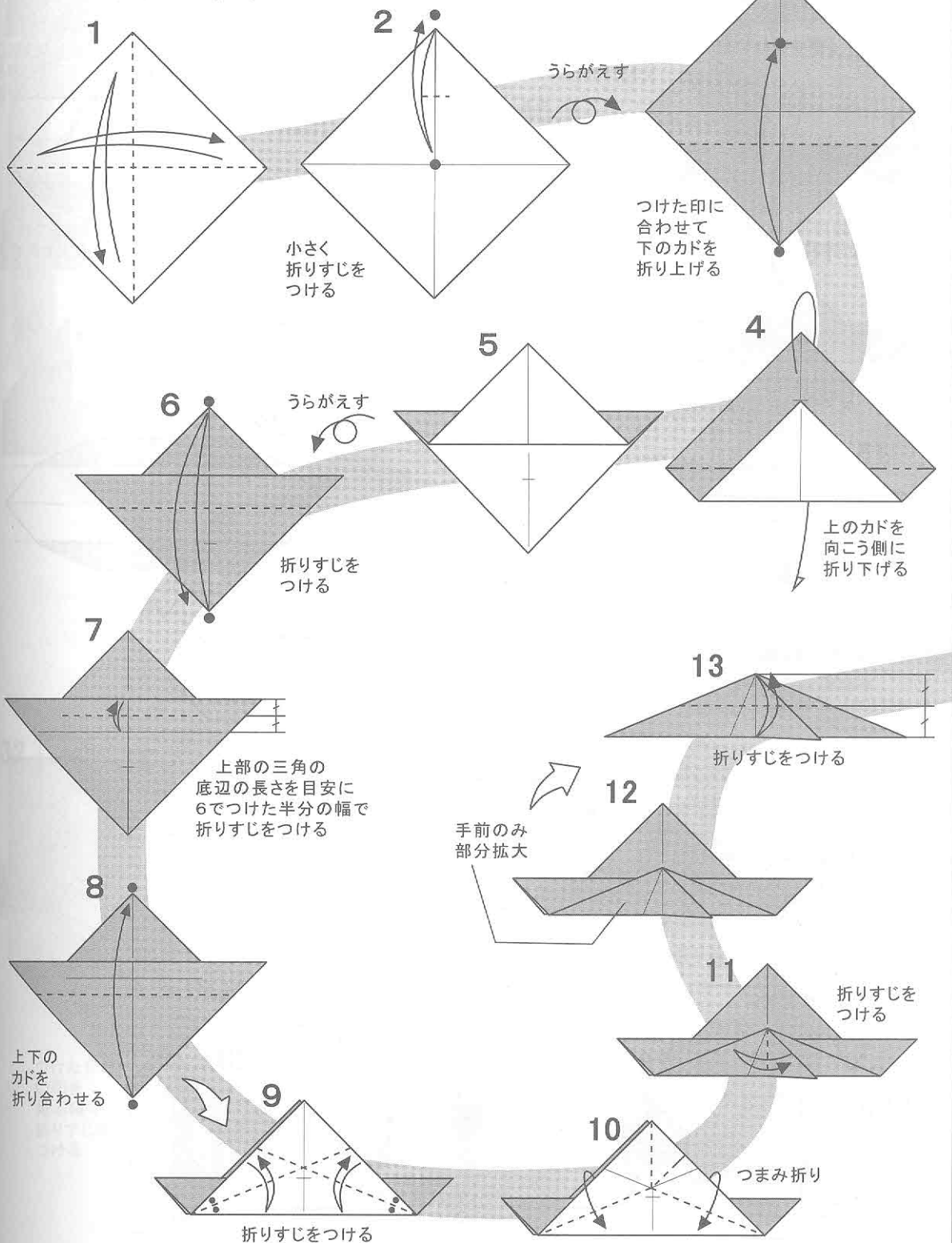



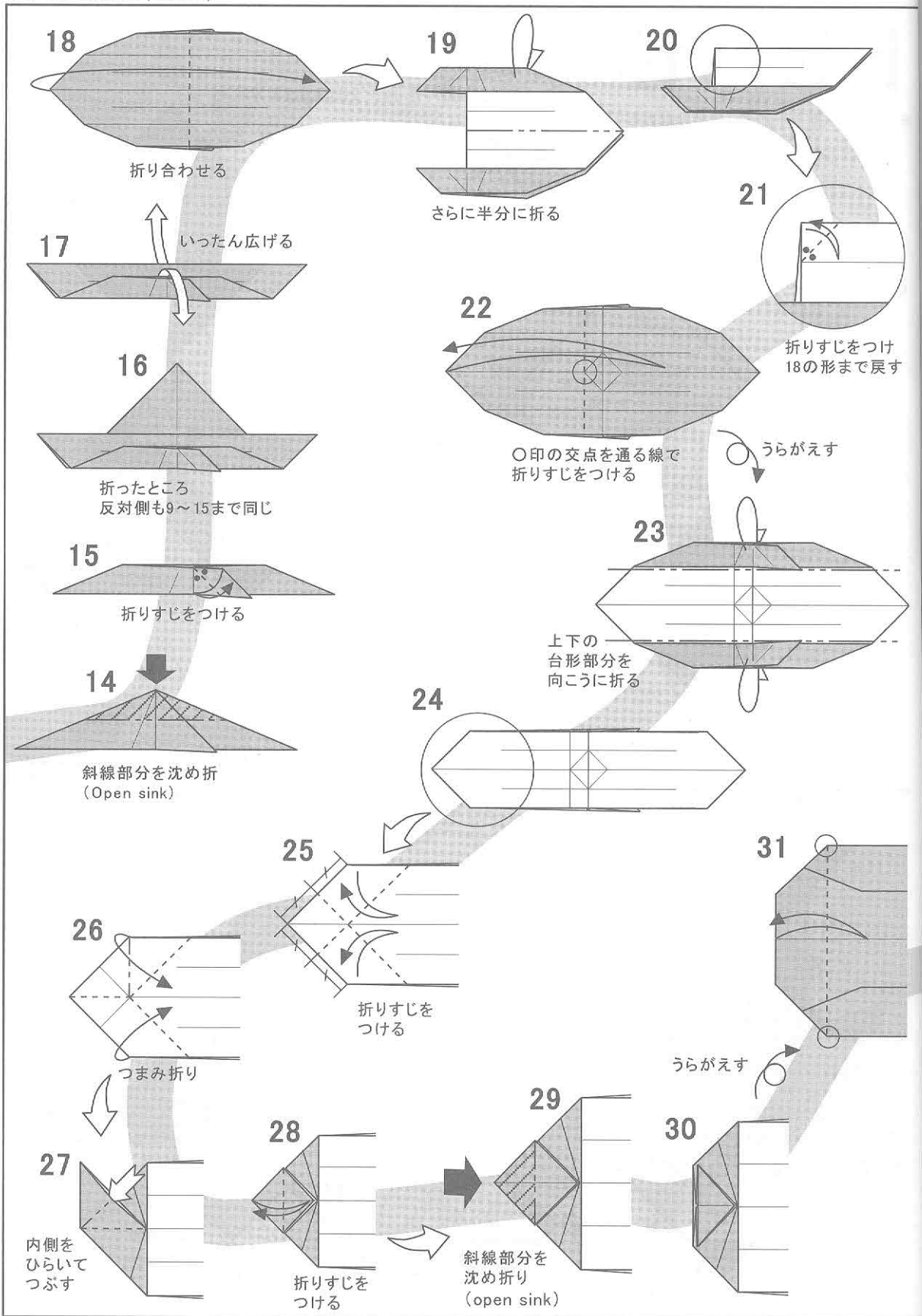

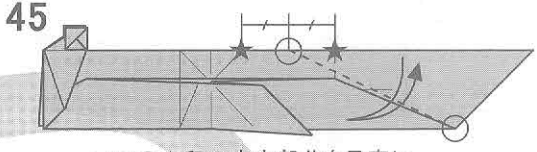
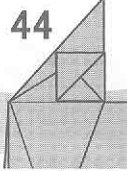
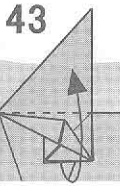
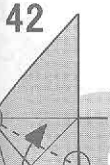
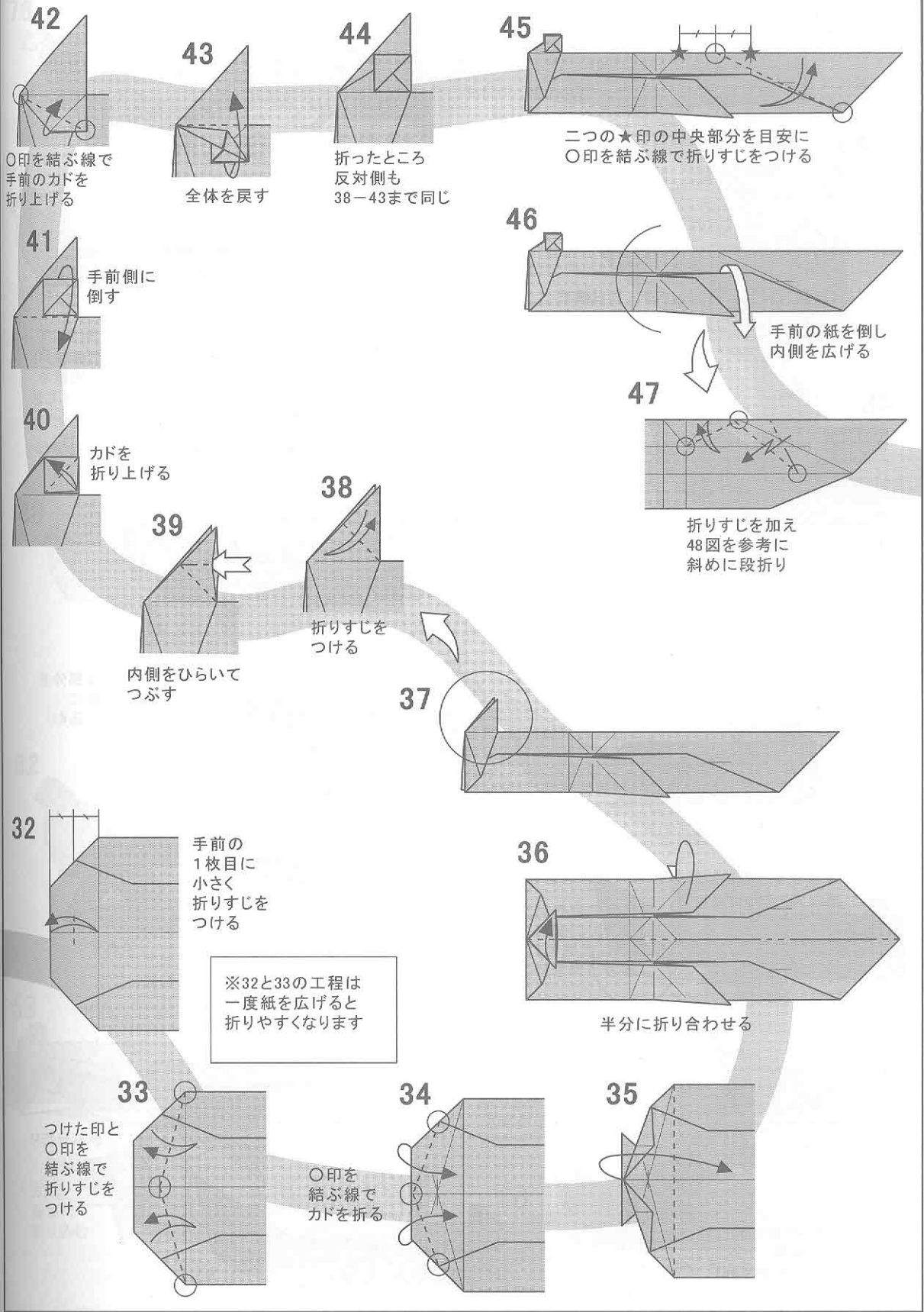

二つの★印の中央部分を目安に  
○印を結ぶ線で折りすじをつける

○印を結ぶ線で  
手前のカドを  
折り上げる

全体を戻す

折ったところ  
反対側も  
38-43まで同じ

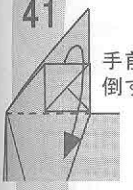

手前側に  
倒す

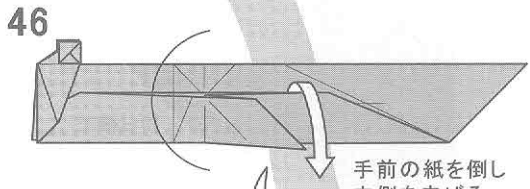

手前の紙を倒し  
内側を広げる

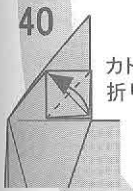

カドを  
折り上げる

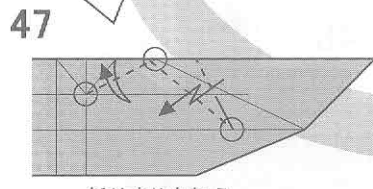

折りすじを加え  
48図を参考に  
斜めに段折り

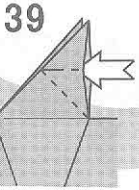

内側をひらいて  
つぶす

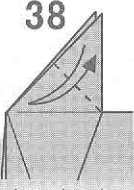

折りすじを  
つける

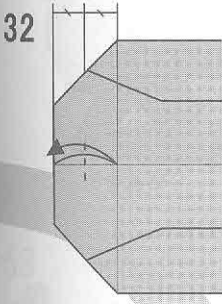
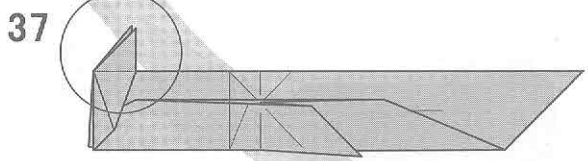

手前の  
1枚目に  
小さく  
折りすじを  
つける

※32と33の工程は  
一度紙を広げると  
折りやすくなります

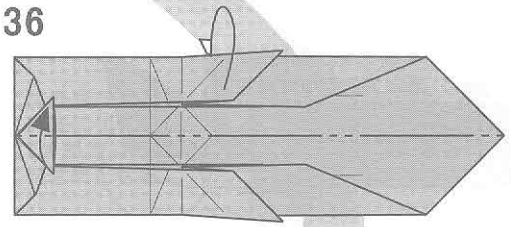

半分に折り合わせる

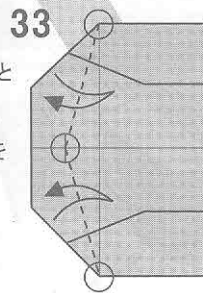

つけた印と  
○印を  
結ぶ線で  
折りすじを  
つける

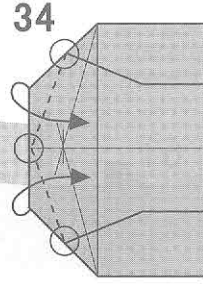

○印を  
結ぶ線で  
カドを折る

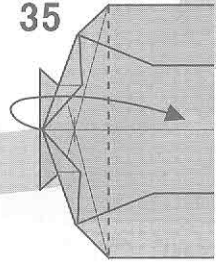

50

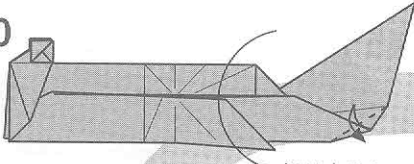

折りすじをつける

51

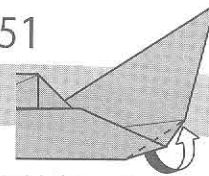

カドを裏返してかぶせ折り

折ったところ  
反対側も  
50~52まで  
同じ

52

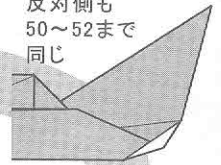

49

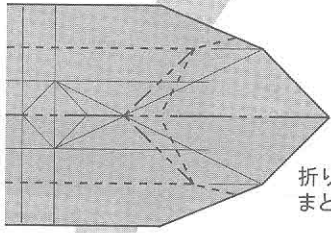

折り線で  
まとめる

53

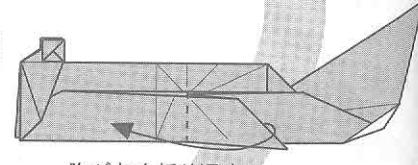

胸びれを折り返す

54

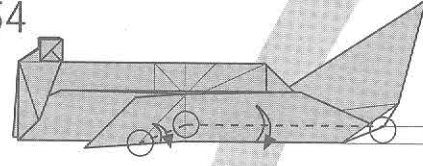

○印を  
結ぶ線で  
折りすじを  
つける

※平行

48

直角

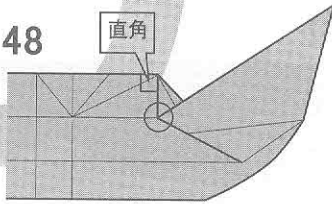

折りすじがいたら  
いったん広げる

55

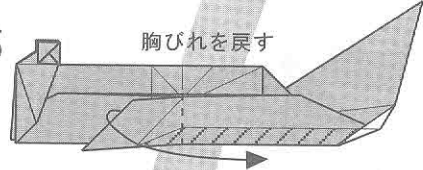

胸びれを戻す

56

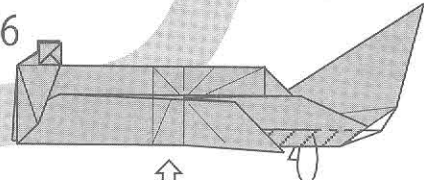

斜線部分を  
内側に  
折り込む

57

反対側も  
53~57まで同じ

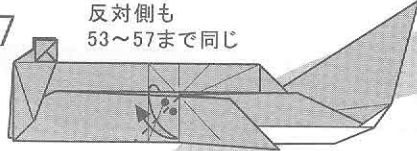

折りすじをつける

58

手前の紙2枚に  
折りすじをつける

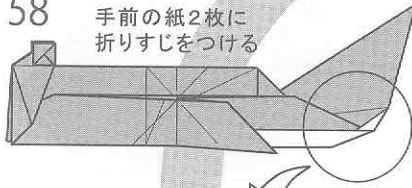

胸びれを  
下から  
見たところ

59

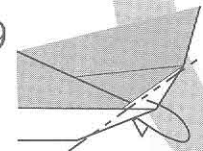

カドを折り込む

62

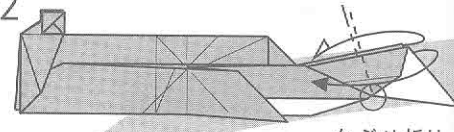

かぶせ折り

60

カドを折り込む  
反対側も  
59~60まで  
同じ

61

尾びれの根元から  
中わり折り

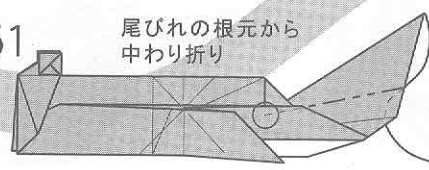

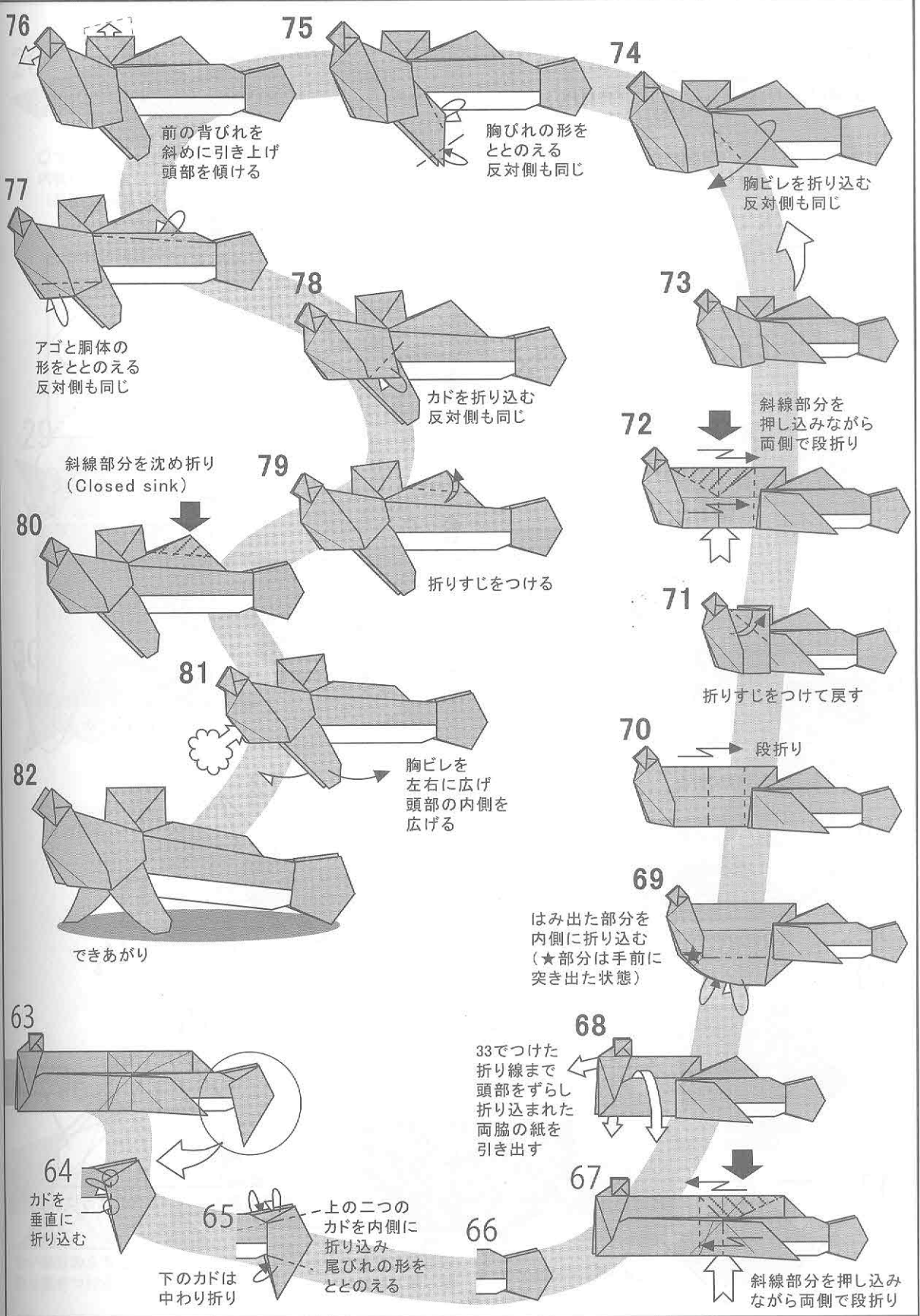

76 前の背びれを斜めに引き上げ 頭部を傾ける

75 胸びれの形をととのえる 反対側も同じ

74 胸ビレを折り込む 反対側も同じ

77 アゴと胴体の形をととのえる 反対側も同じ

78 カドを折り込む 反対側も同じ

73 斜線部分を押し込みながら 両側で段折り

79 斜線部分を沈め折り (Closed sink)

80 折りすじをつける

72 折りすじをつけて戻す

81 できあがり

82 胸ビレを左右に広げ 頭部の内側を広げる

71 折りすじをつけて戻す

70 段折り

69 はみ出た部分を内側に折り込む (★部分は手前に突き出した状態)

68 33でつけた折り線まで 頭部をずらし 折り込まれた両脇の紙を引き出す

64 カドを垂直に折り込む

65 上の二つのカドを内側に折り込み 尾びれの形をととのえる 下のカドは中わり折り

67 斜線部分を押し込みながら 両側で段折り

# さめ

各務 均

Shark

Kakami Hitoshi

創作 2007年 4月

作図 2013年 6月

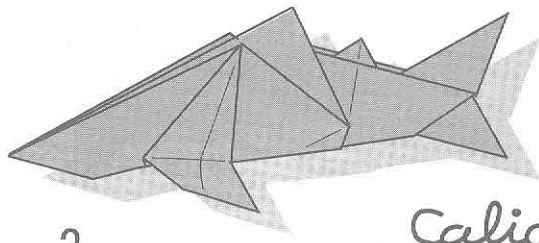

1

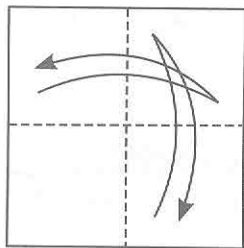

折り筋をつける

2

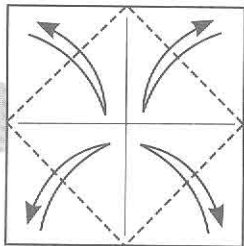

折り筋をつける

3

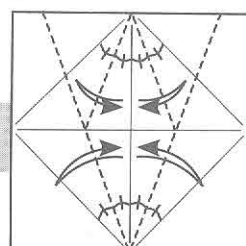

折り筋をつける

4

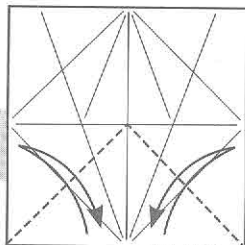

折り筋をつける

Calico

7

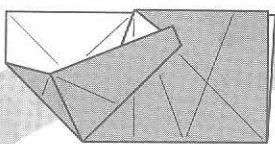

途中の図

6 ↓

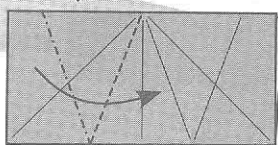

開いてつぶすように折る

5

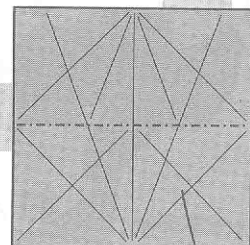

後ろに山折り

8

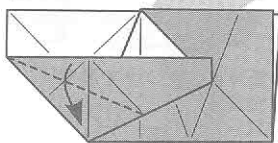

次の図を参考に  
ふちを合わせるように折る

9



次の図を参考に  
右側から自然にたたむ

10

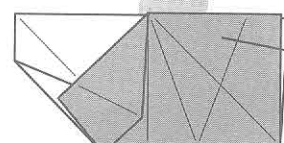

6-9

反対側も6~9と  
同じように折る

11

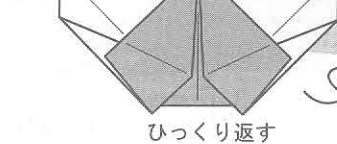

ひっくり返す

13

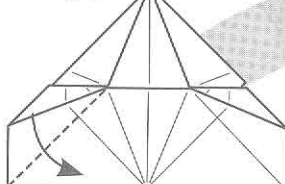

ついている折り筋で  
谷折り

12

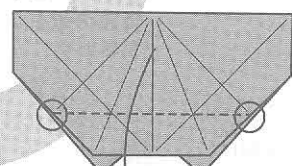

○で囲んだ点を  
結ぶ線で谷折り

14

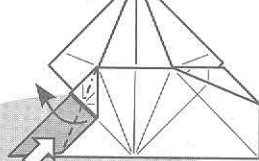

上から2枚目のところを  
開いてつぶすように折る

15

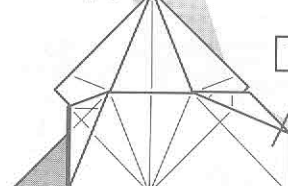

反対側も13~14と同じように折る

13-14

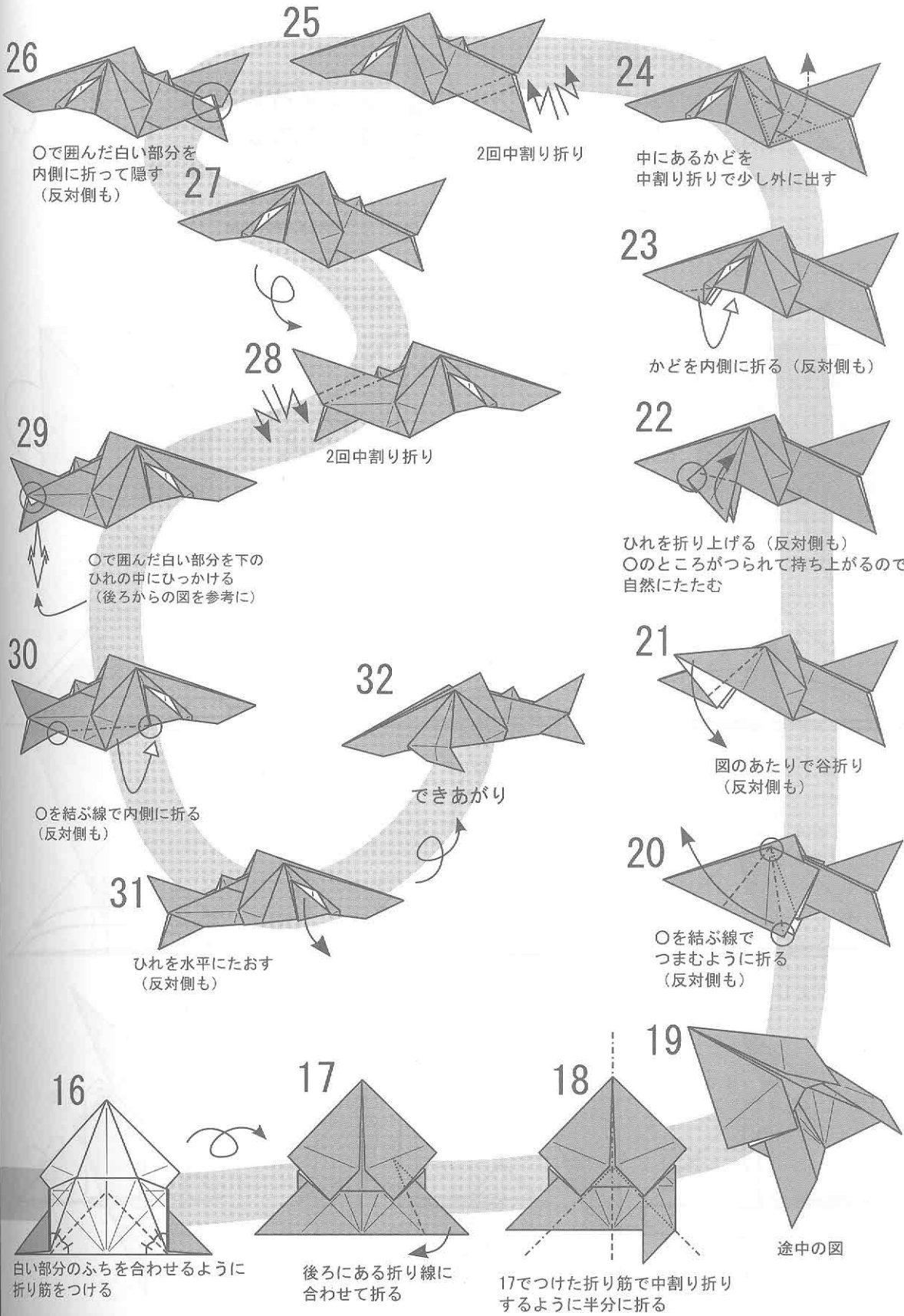

26  
○で囲んだ白い部分を  
内側に折って隠す  
(反対側も)

2回中割り折り

24  
中にあるかどを  
中割り折りですし外に出す

23  
かどを内側に折る (反対側も)

29  
○で囲んだ白い部分を下の  
ひれの中にひっかける  
(後ろからの図を参考に)

2回中割り折り

22  
ひれを折り上げる (反対側も)  
○のところがつられて持ち上がるので  
自然にたたむ

30  
○を結ぶ線で内側に折る  
(反対側も)

できあがり

21  
図のあたりで谷折り  
(反対側も)

31  
ひれを水平にたおす  
(反対側も)

20  
○を結ぶ線で  
つまむように折る  
(反対側も)

16  
白い部分のふちを合わせるように  
折り筋をつける

17  
後ろにある折り線に  
合わせて折る

18  
17でつけた折り筋で中割り折り  
するように半分に折る

19  
途中の図

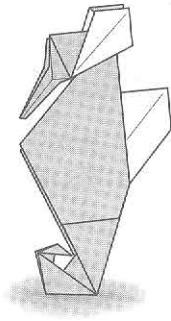

タツノオトシゴ  
Sea horse

前川淳  
MAEKAWA Jun

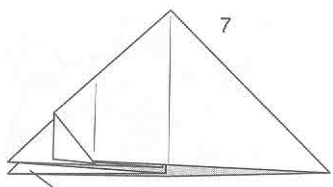
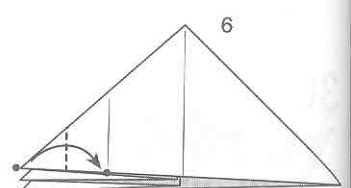
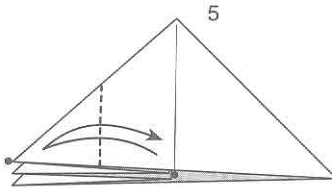
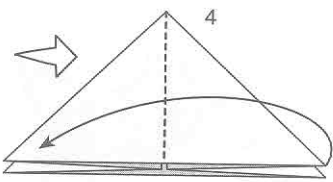
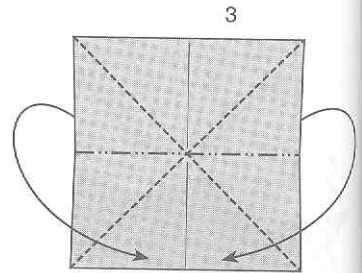
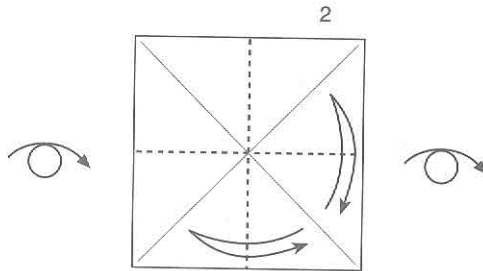
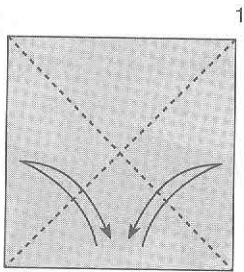

うらがえして、5-6と同じ

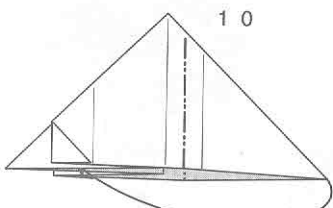
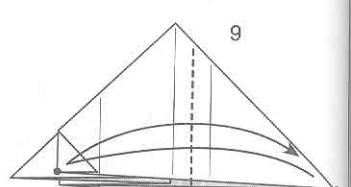
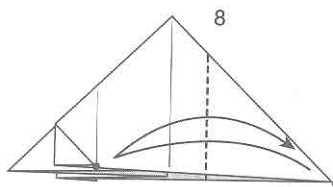

工程9の折り目で  
中割り折り。

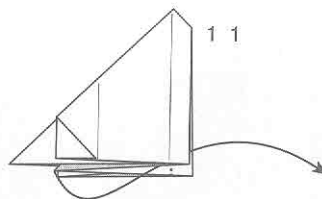

工程8の折り目で  
中割り折り。

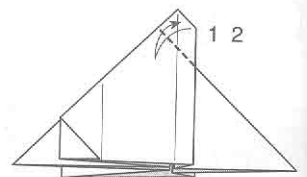

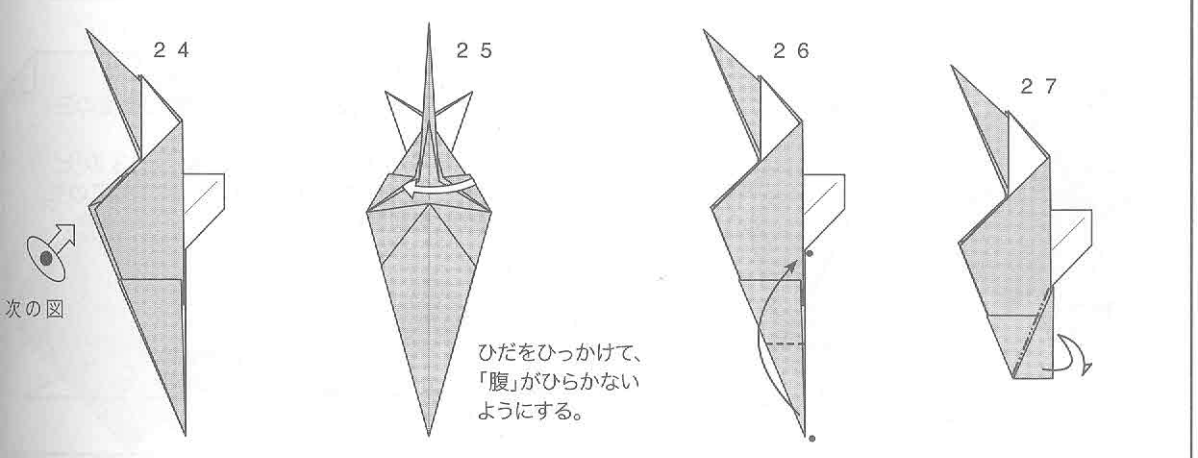
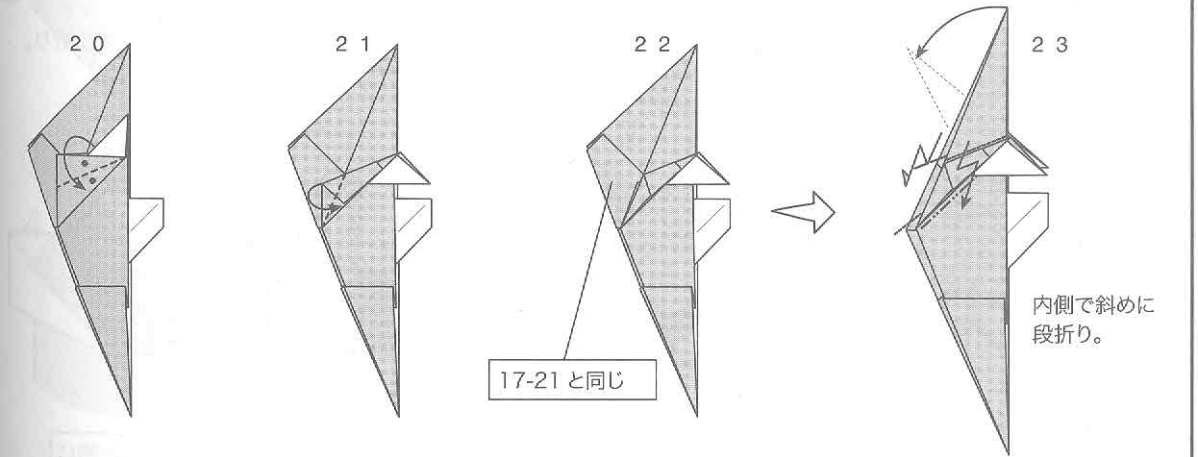
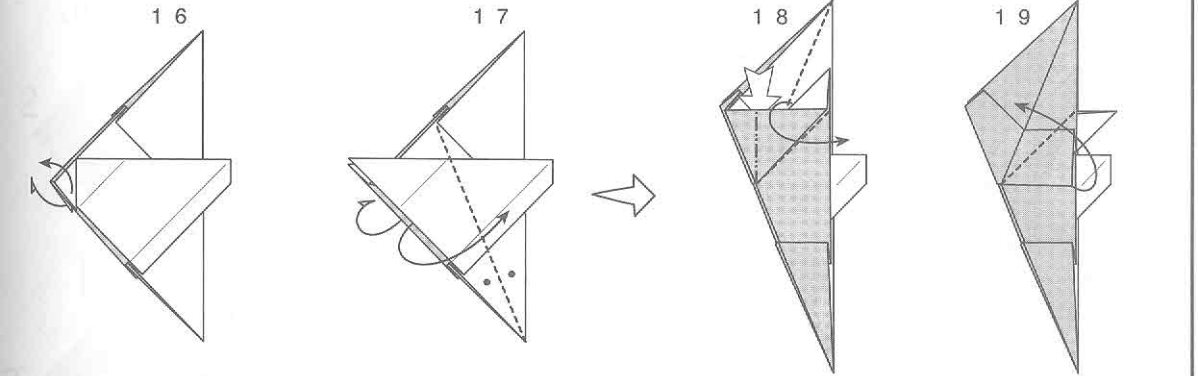
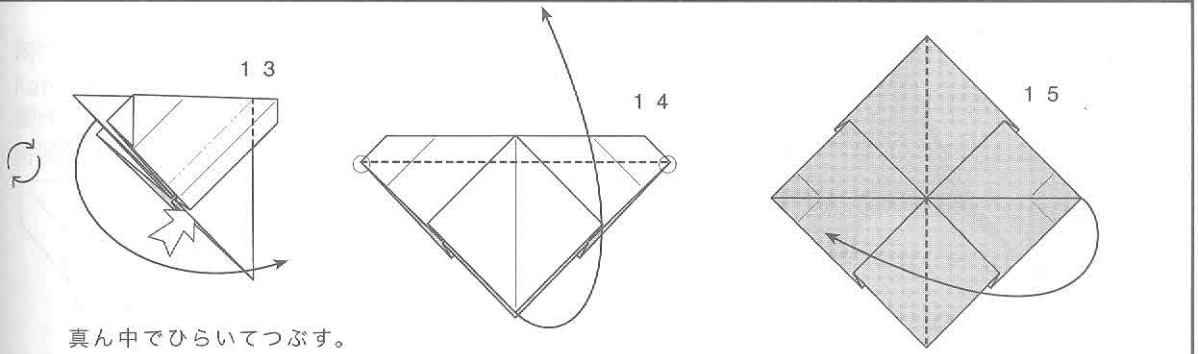



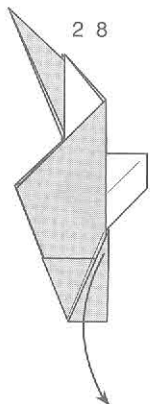

28

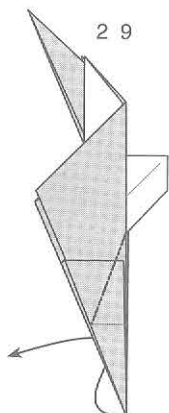

29

中割り折り。

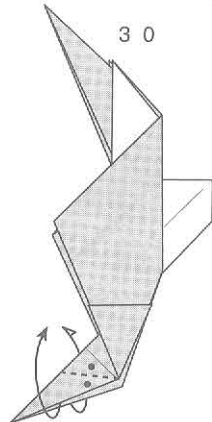

30

かぶせ折り。

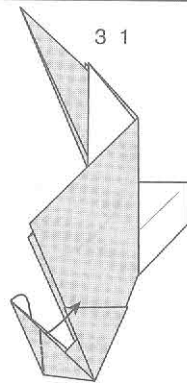

31

中割り折り。

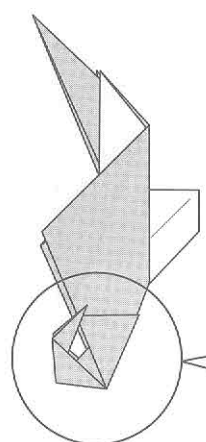

32

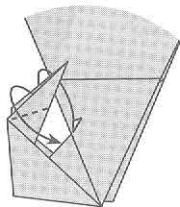

かぶせ折り。

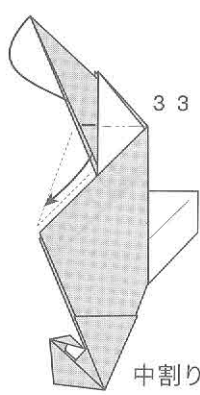

33

中割り折り。

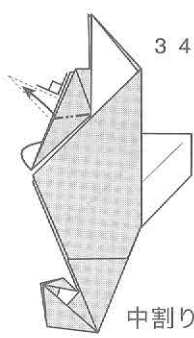

34

中割り折り。

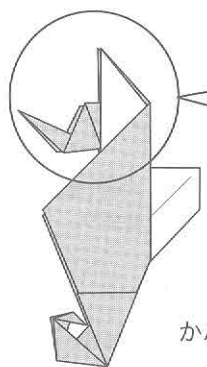

35

かぶせ折り。

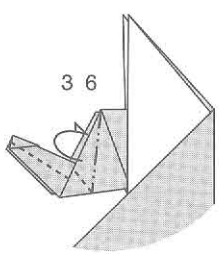

36

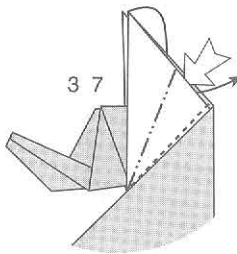

37

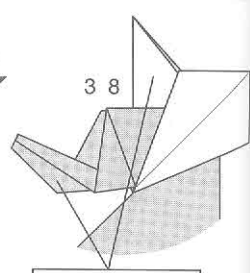

38

36-37と同じ

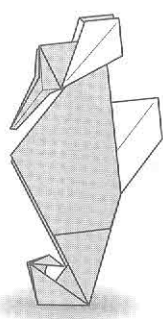
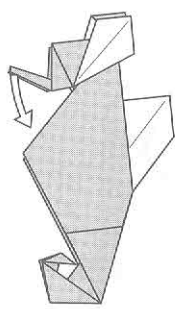

自立します。  
「立つの!オトシゴ」

折り鶴などでなじみの、22.5度、67.5度、90度の三角形(図左)は、辺の比率でいうと、 $1 : 2.41... : 2.61...$  になります。これは、5:12:13の「ピタゴラス三角形」(図右)にきわめて近い比率です。このモデルは、この近似を利用しています。

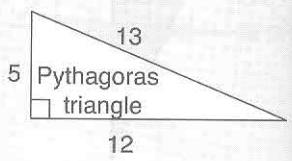
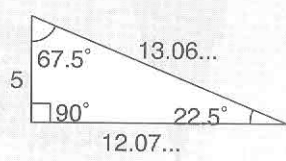

創作&折図 山北克彦  
Katsuhiko Yamakita  
創作 2012. 11 月  
折図 2013. 6 月

# イルカ

Dolphin

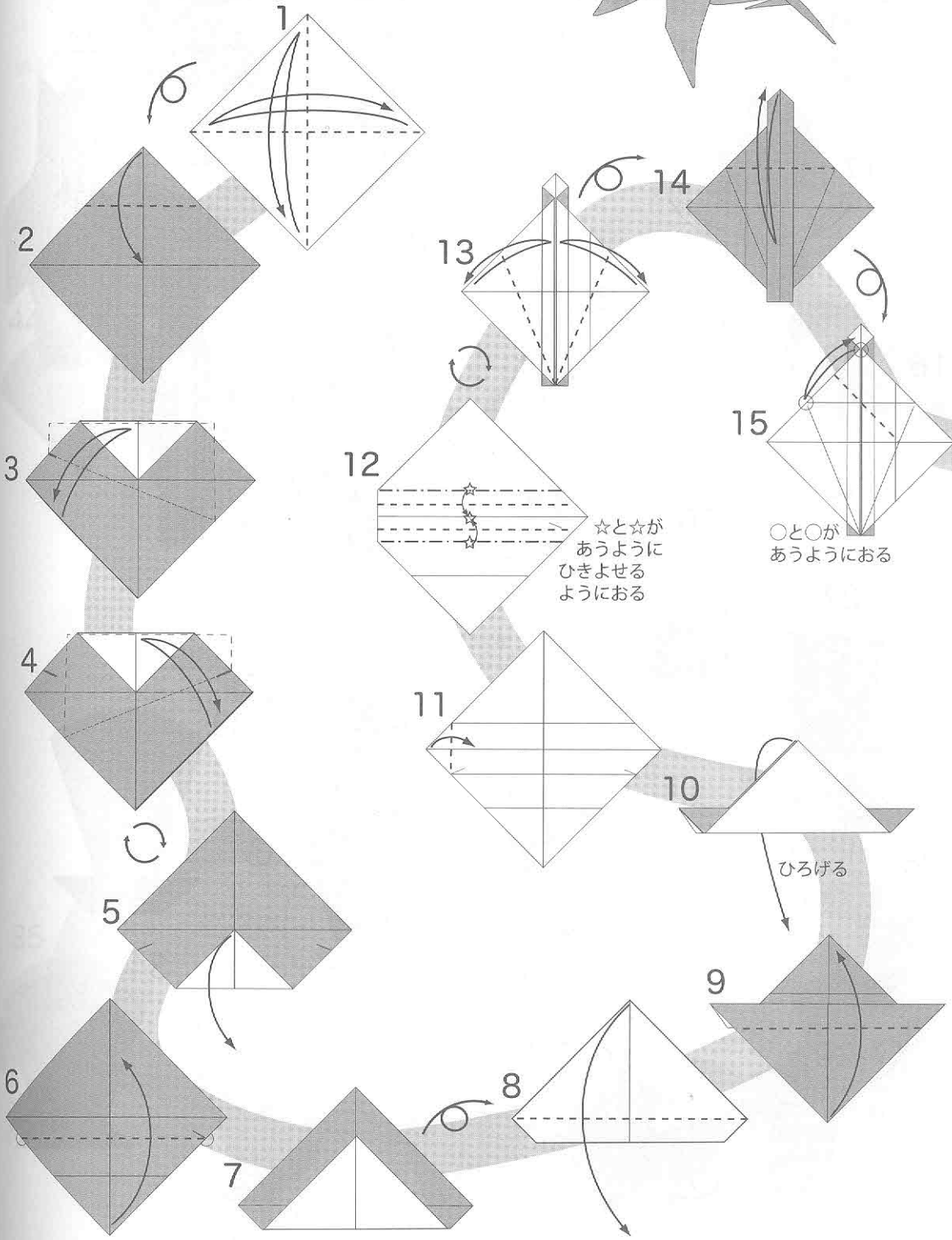
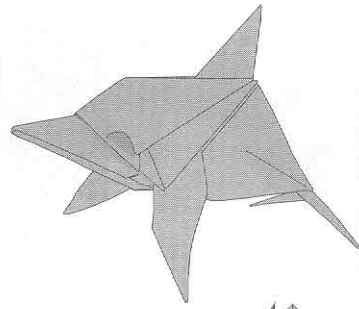

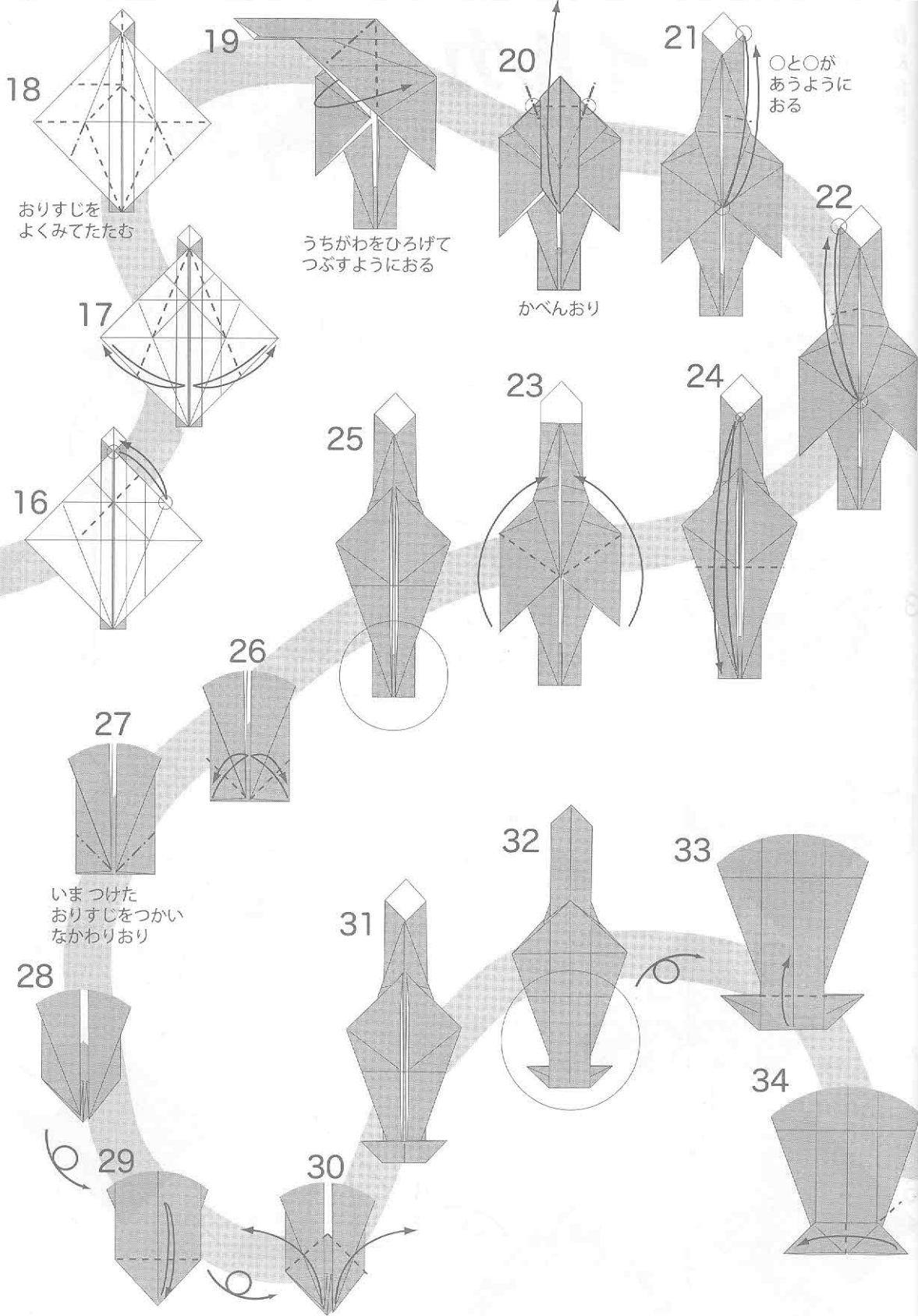

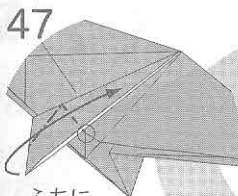

47  
ふちに  
そっておりあげる  
おきあがってきた  
かみもおなじ

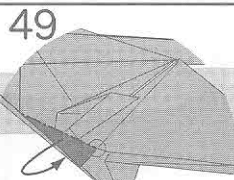
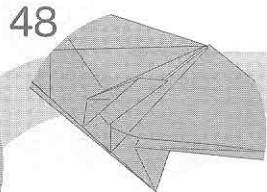

49  
うらがわへおる

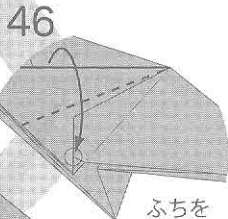
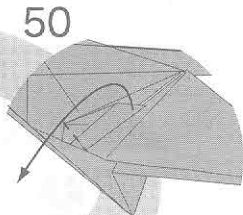

46  
ふちを  
○にあわせる

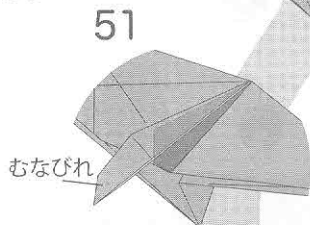
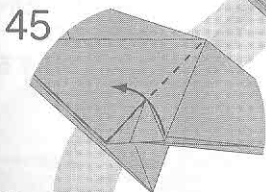

51  
「むなびれ」と「▽」の  
そうを 入れかえる。

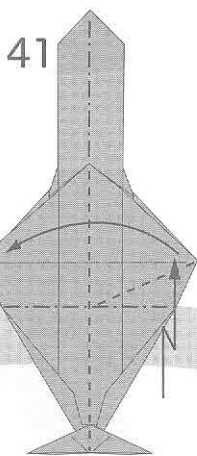
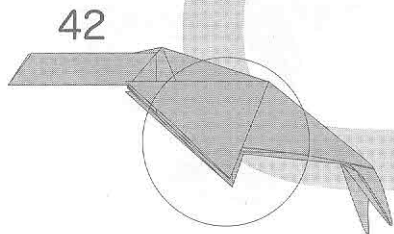
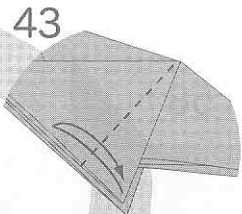
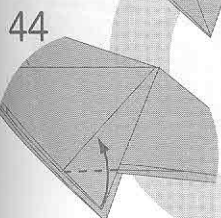

41  
つぎの「ず」の  
ようにおりたたむ

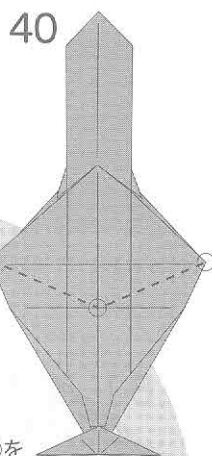

40  
○と○を  
むすぶせんでおりすじを  
つける

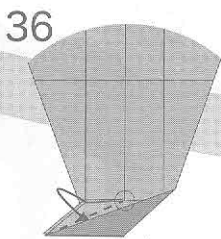
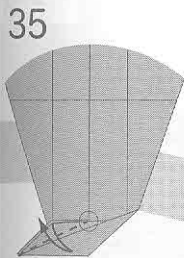

36  
■のうちがわへ  
いれこむ

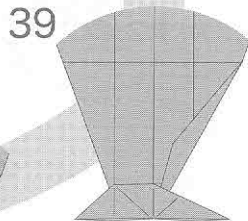
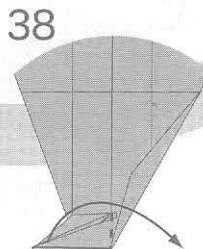
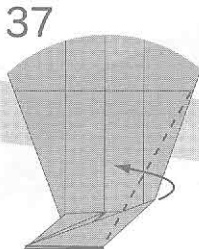

39  
ひだりがわも  
おなじようにおる  
(34~38)

55

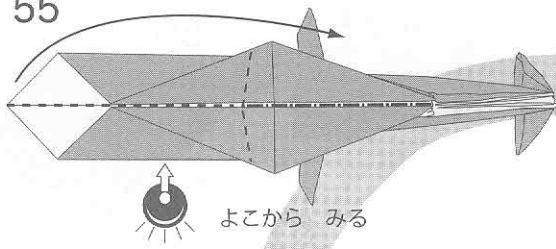

よこから みる

56

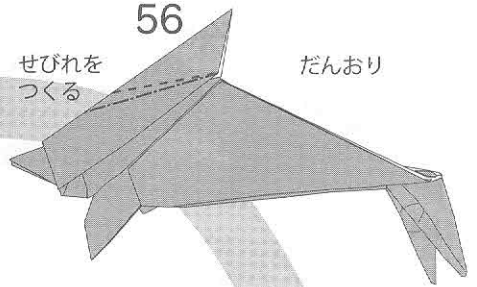

せびれを  
つくる

だんおり

54

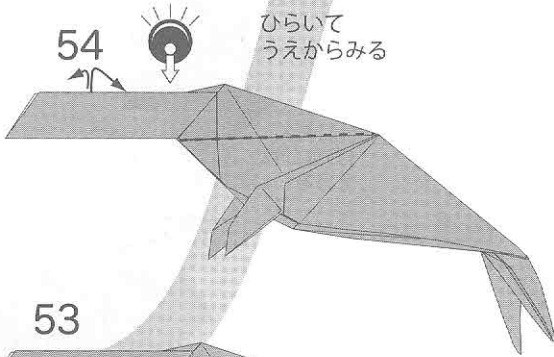

ひらいて  
うえからみる

せびれ

ひだを なかへ  
さしこむ  
(のりづけするとよい)

57

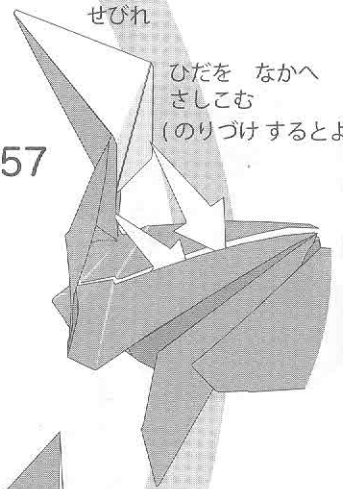

53

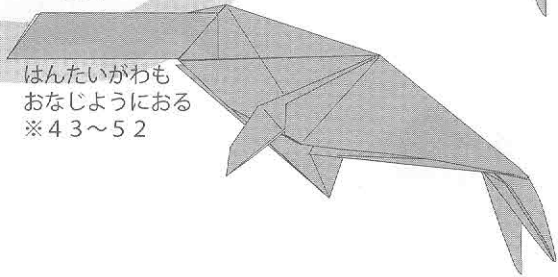

はんたいがわも  
おなじようにおる  
※43~52

58

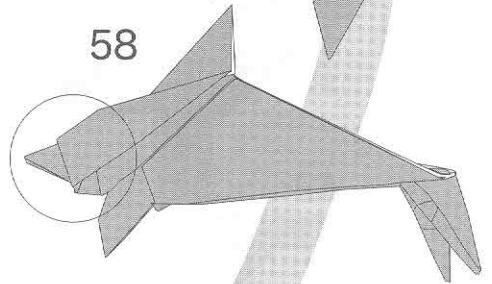

60

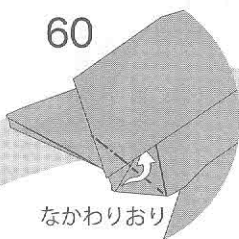

なかわりおり

59

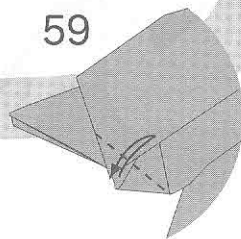

61

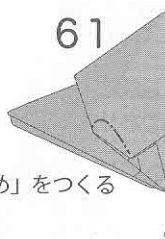

「め」をつくる

62

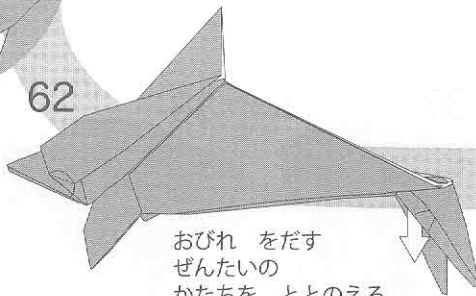

おびれ をだす  
ぜんたいの  
かたちを ととのえる

63

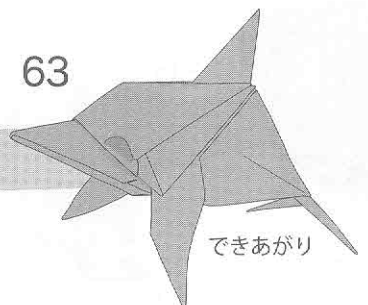

できあがり

# タマカイ

## Giant grouper

\*推奨用紙サイズ: 35 cm

\*のりづけを使用

創作・折図 柏村卓朗

Model and Diagrams: KASHIWAMURA Takuro

Designed in Feb. 2013 Diagrammed in Mar. - Apr. 2013

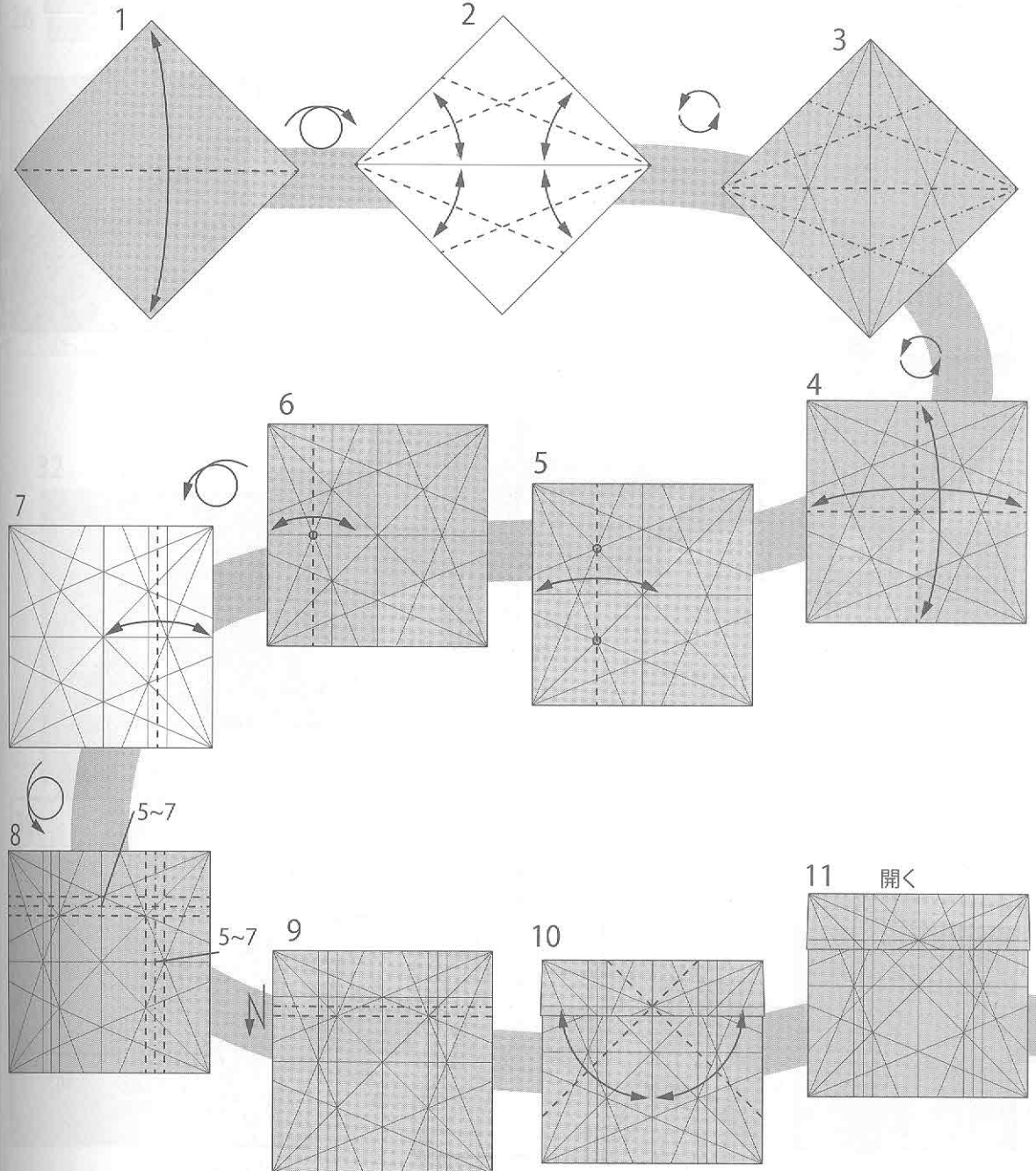
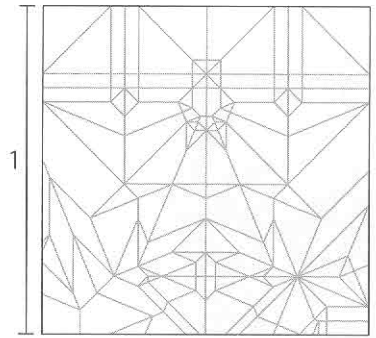
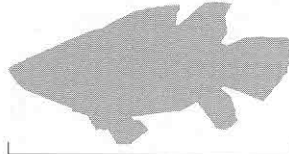

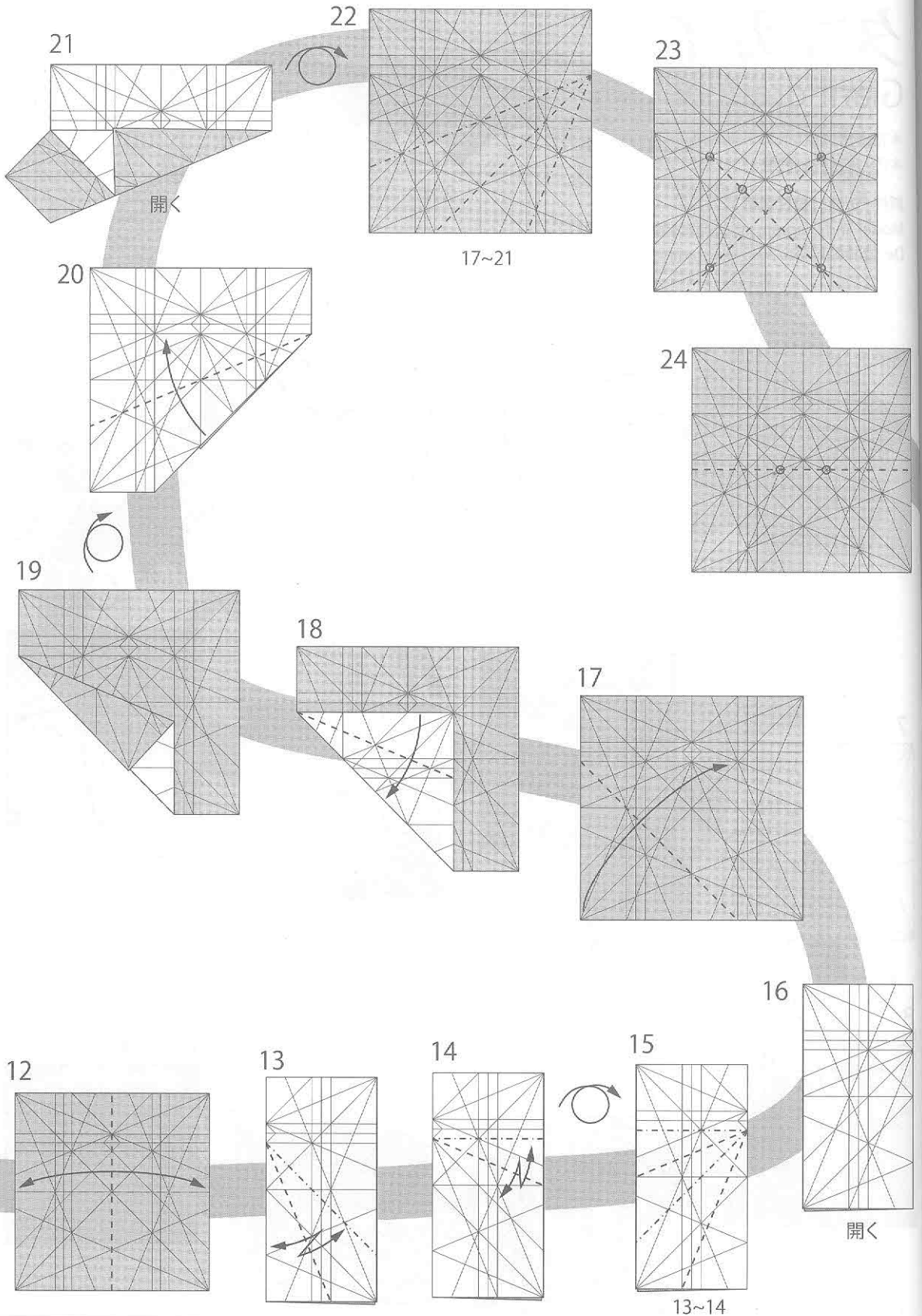

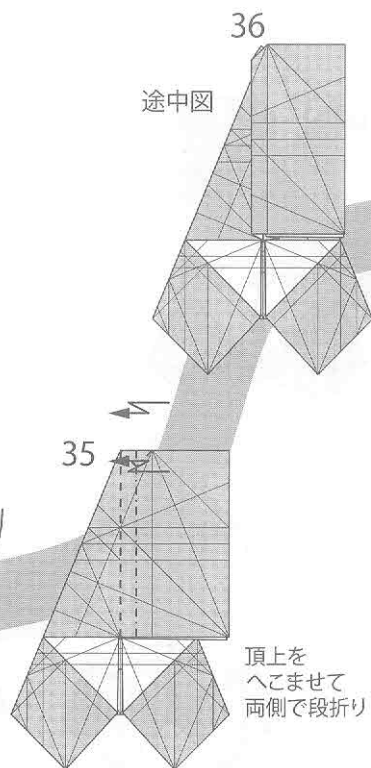
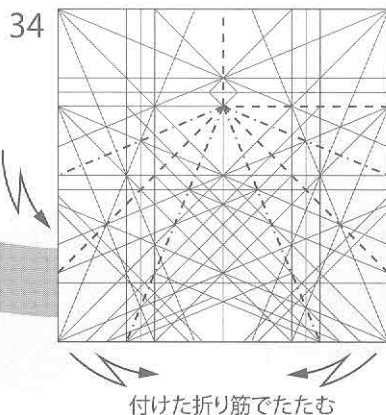
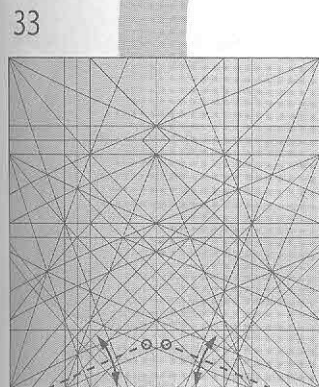
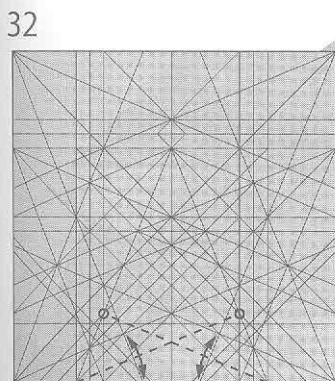
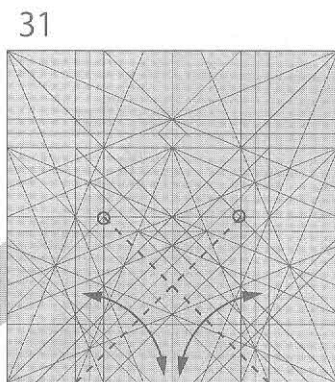
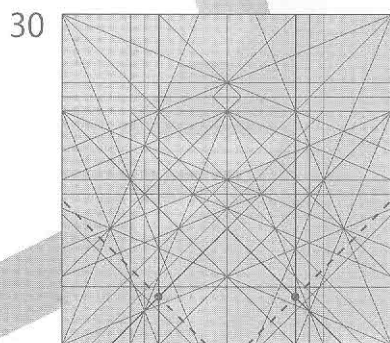
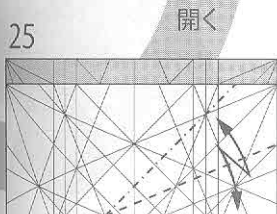
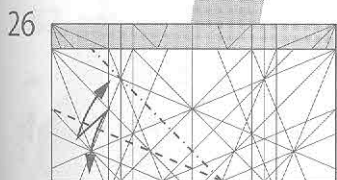
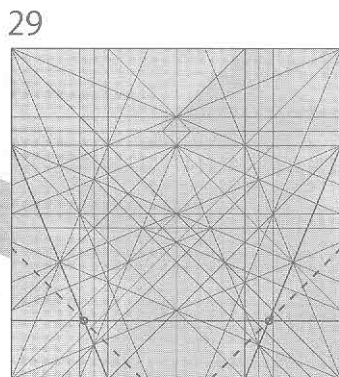
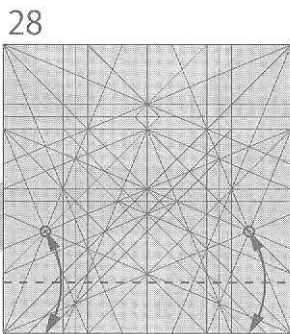
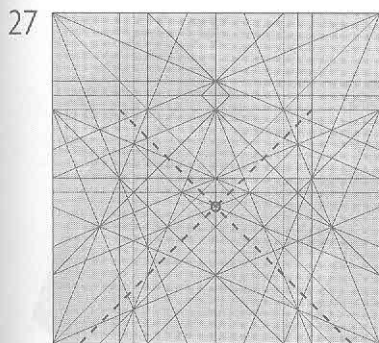



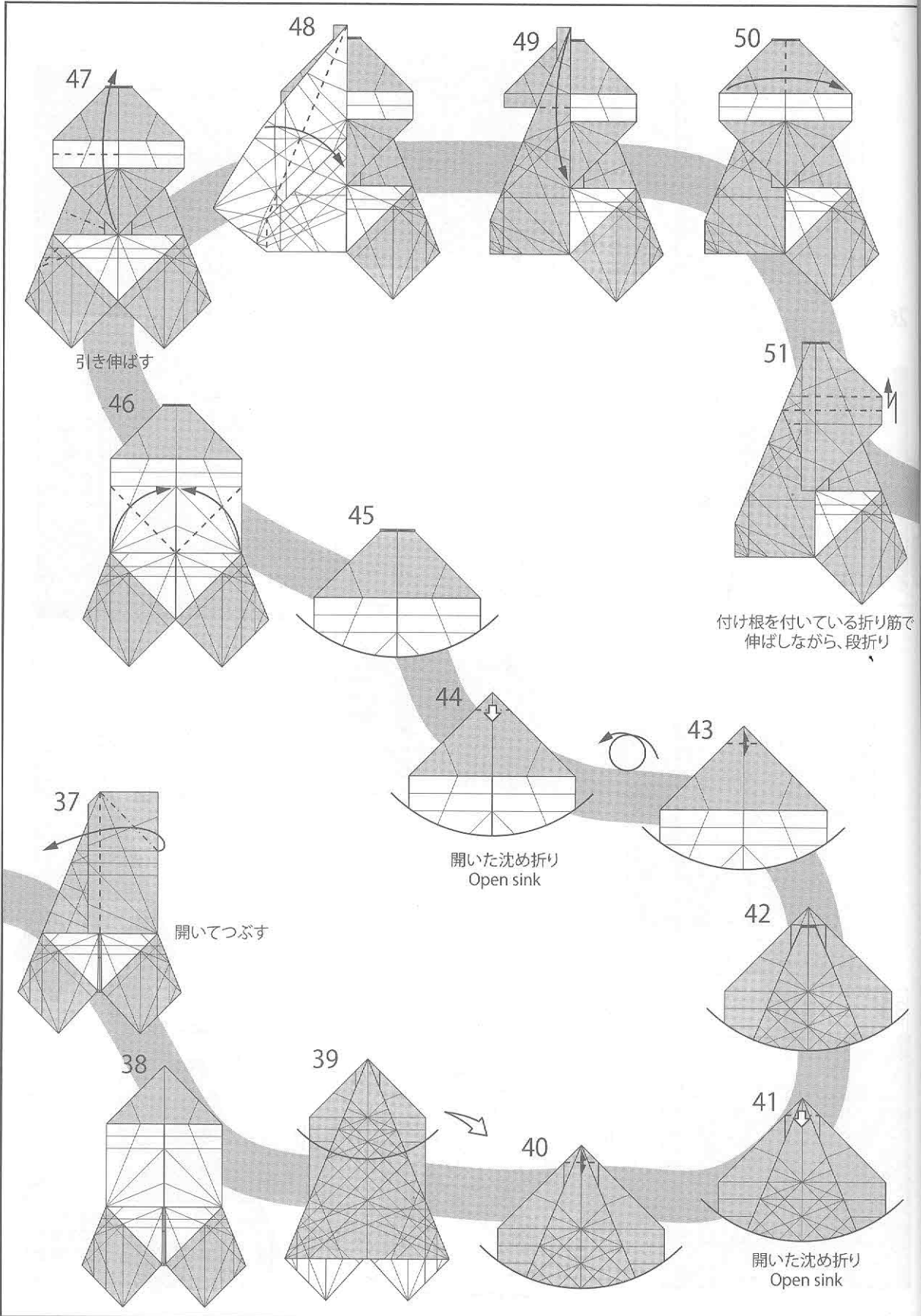

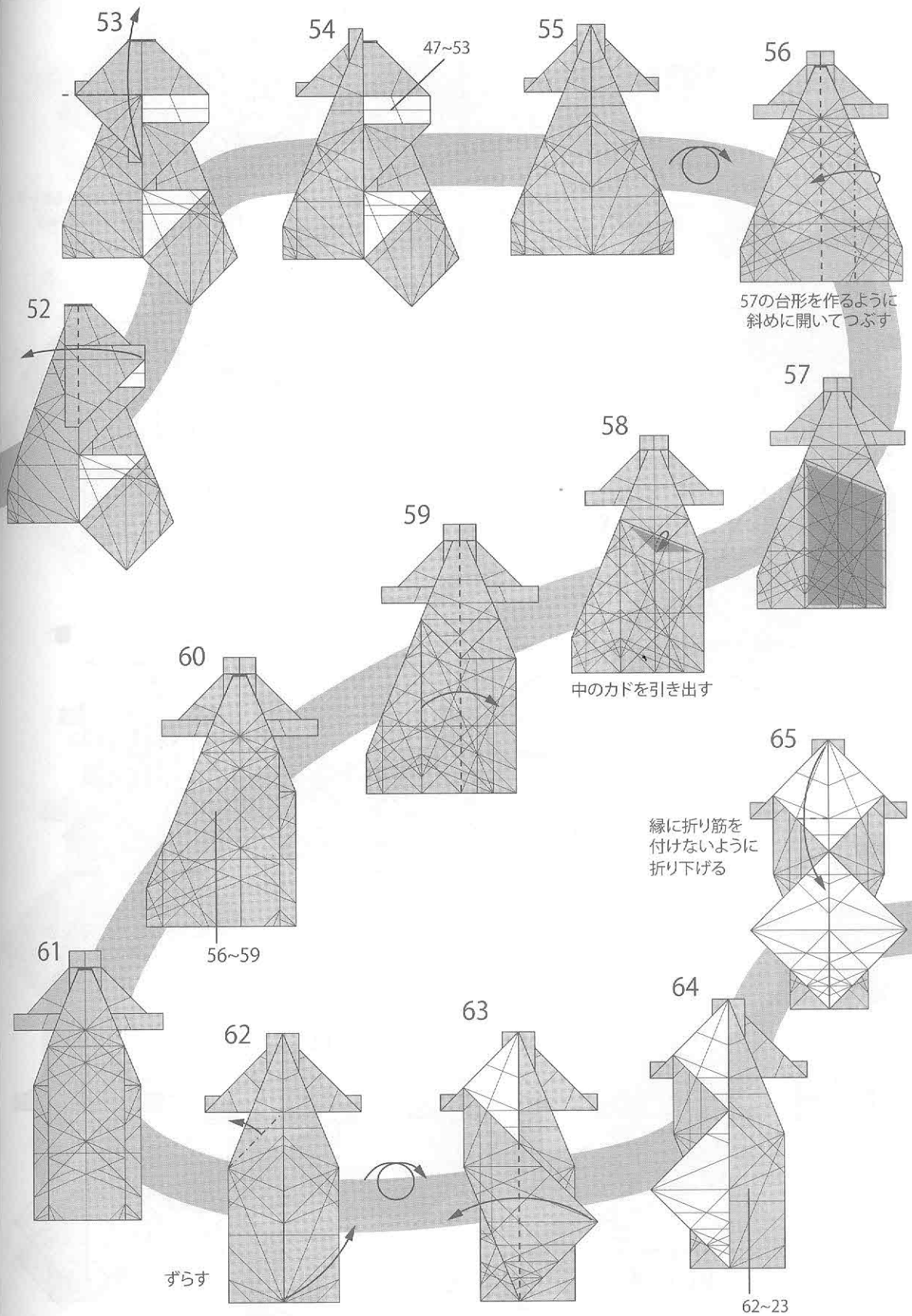

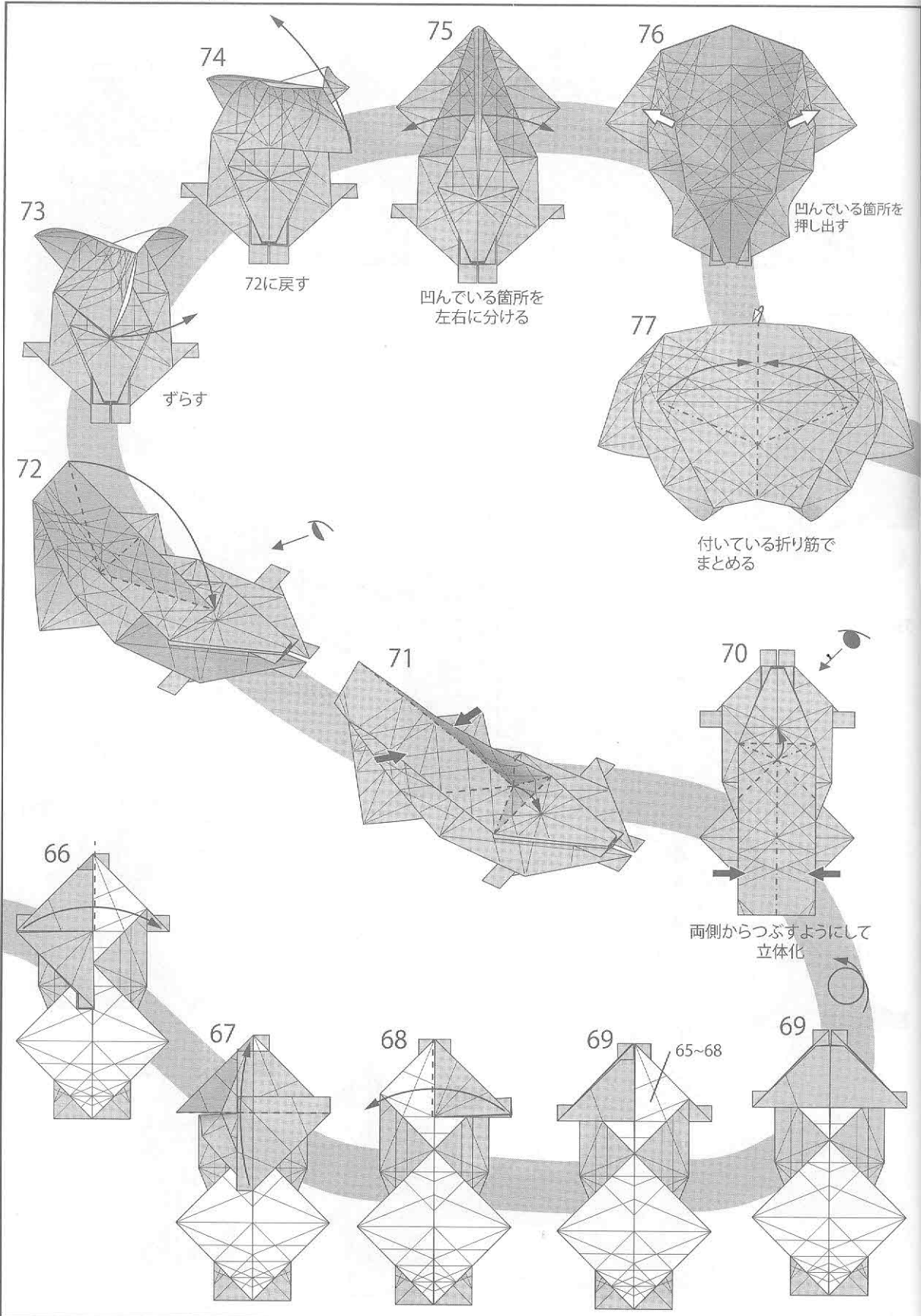

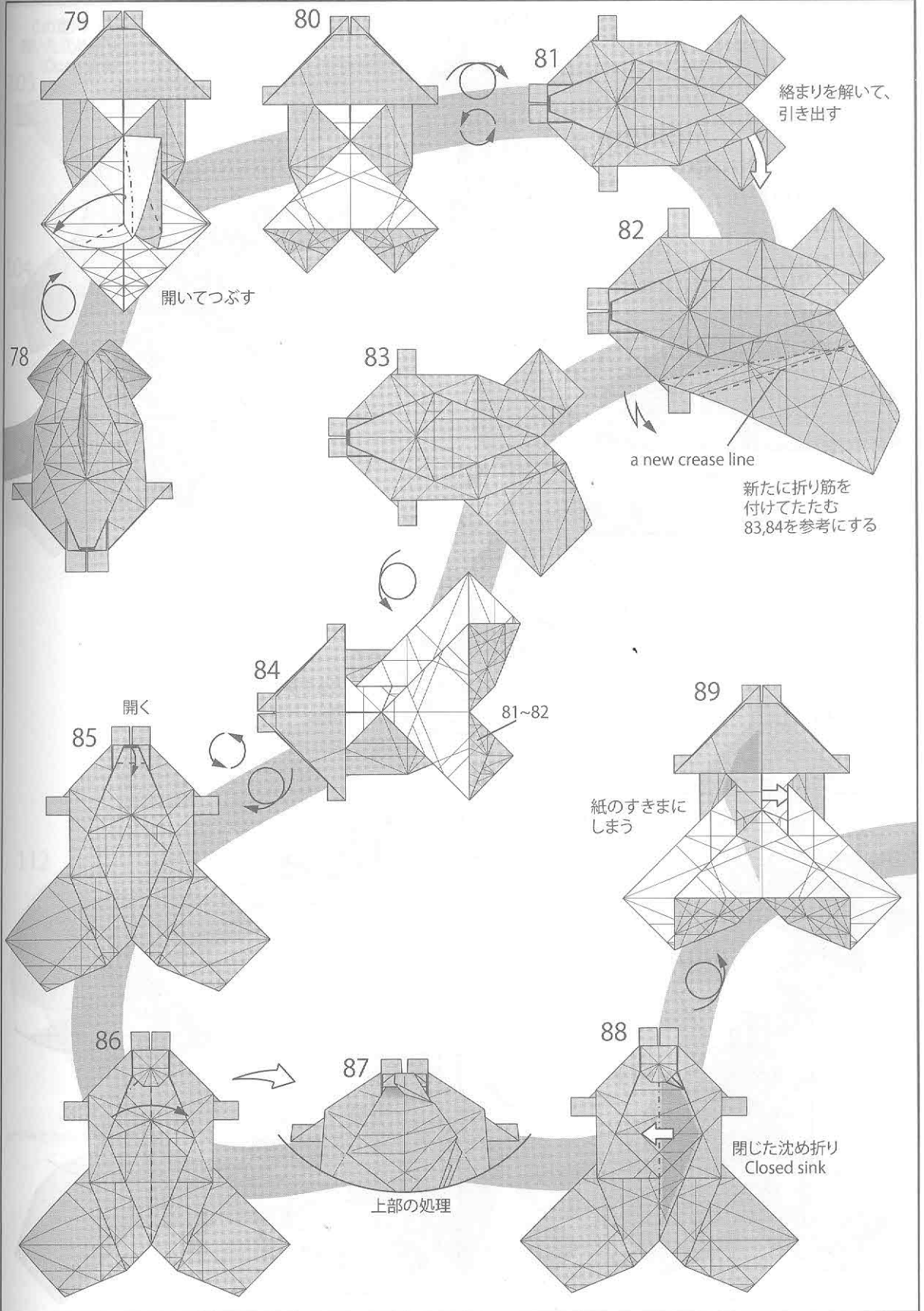

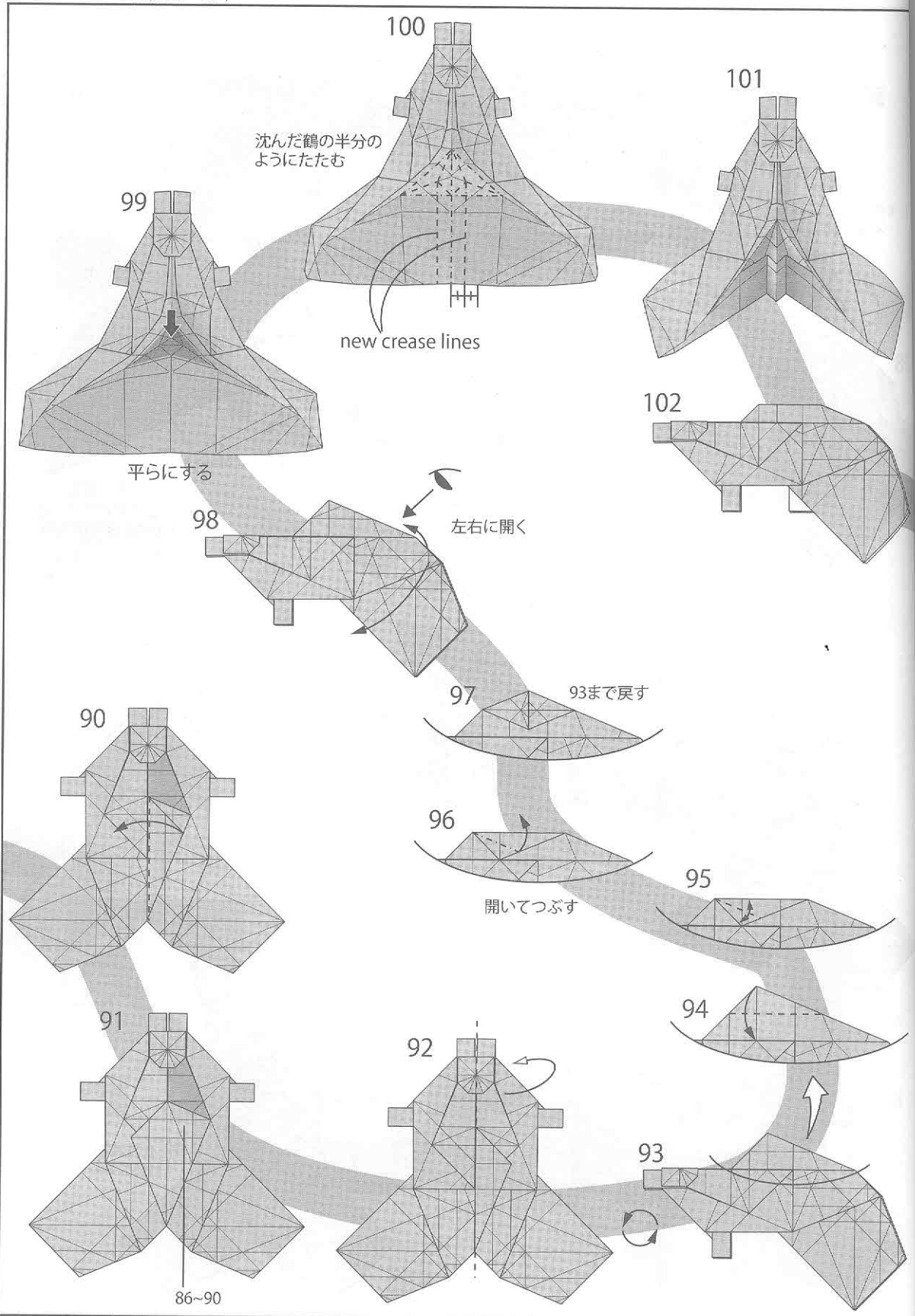

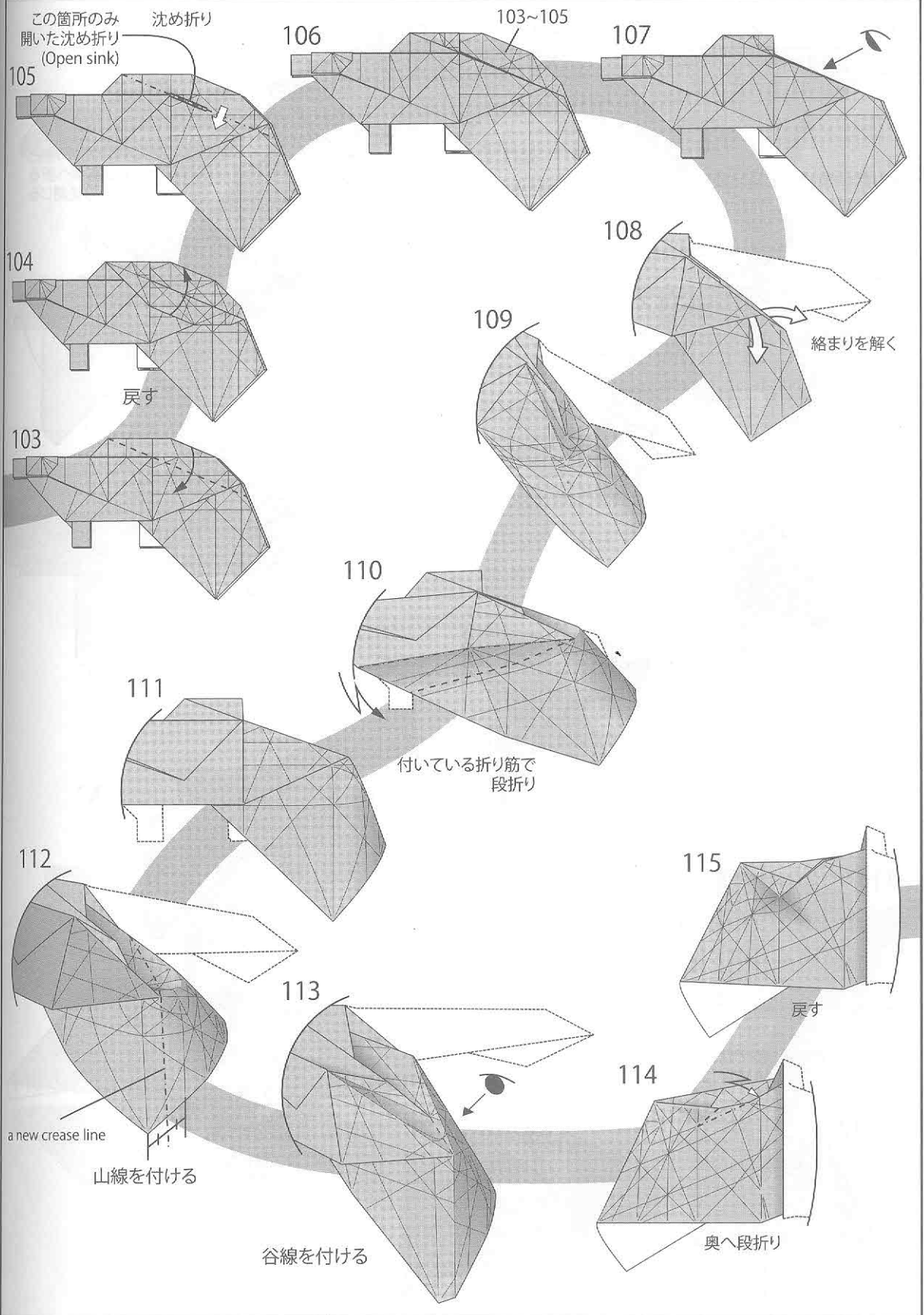

124

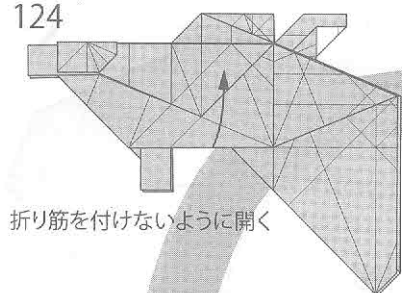

折り筋を付けないように開く

125

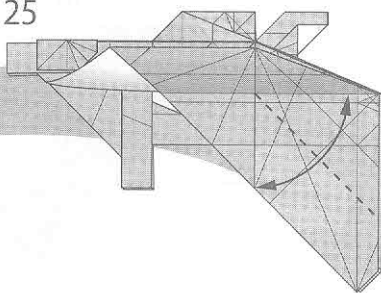

この縁と125で付けた折り筋と  
合わせて裏側へ折る  
その後閉じる

123

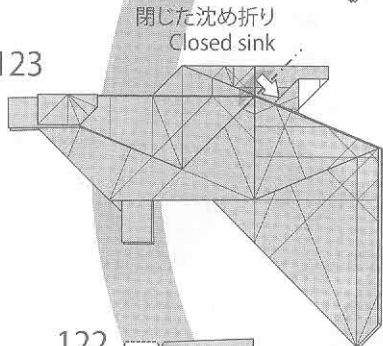

閉じた沈め折り  
Closed sink

126

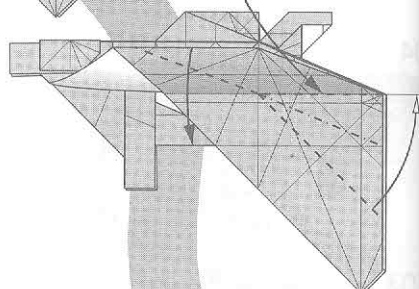

122

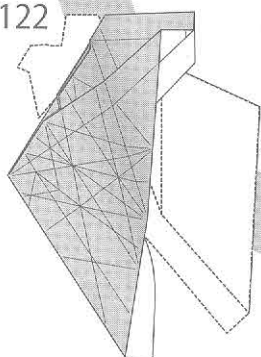

121

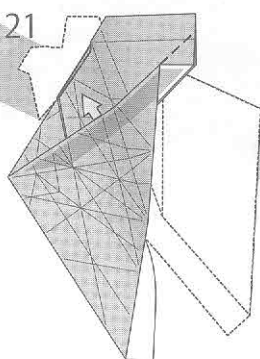

127

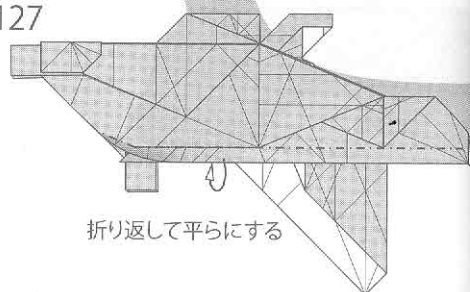

折り返して平らにする

116

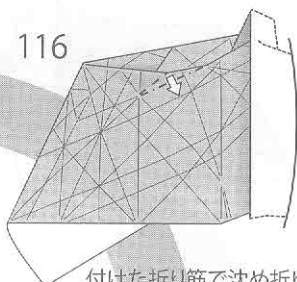

付けた折り筋で沈め折り  
Open sink

120

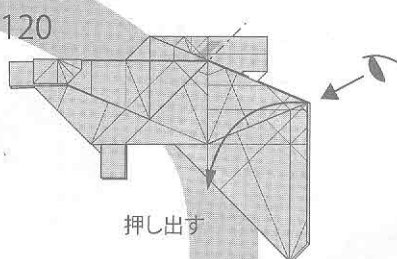

押し出す

117

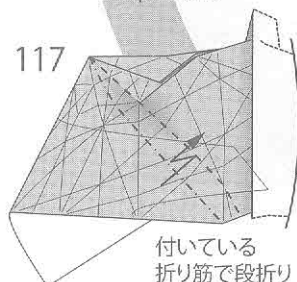

付いている  
折り筋で段折り

119

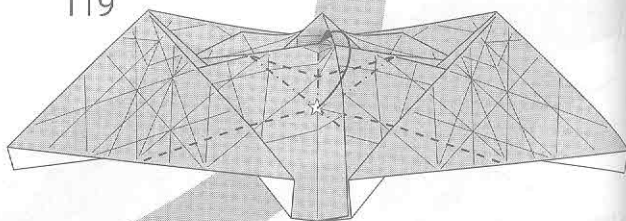

☆を回転させるようにして  
凹みに入れる

118

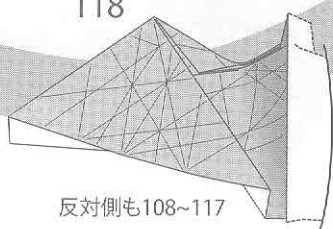

反対側も108~117

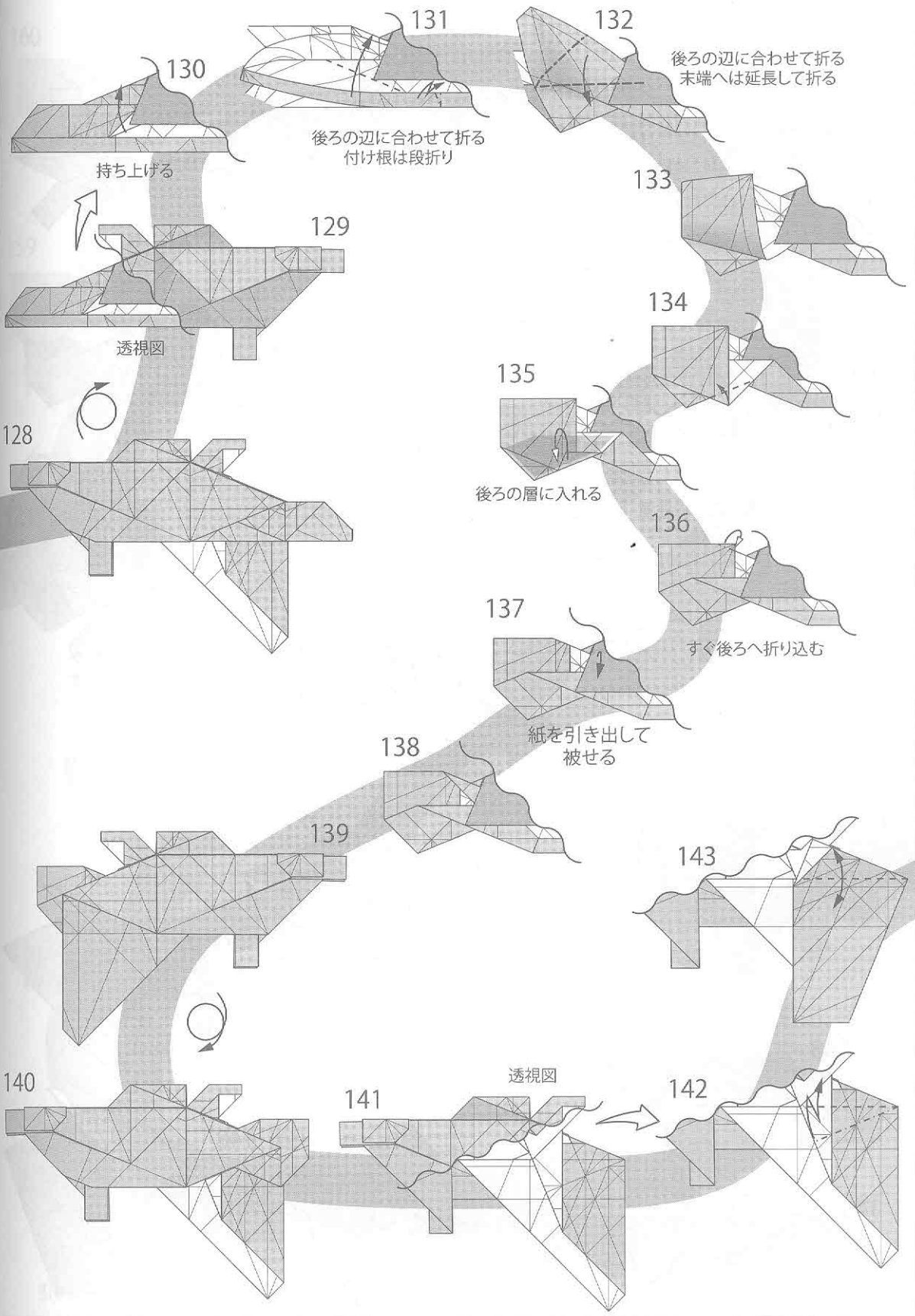

持ち上げる

後ろの辺に合わせて折る  
付け根は段折り

後ろの辺に合わせて折る  
末端へは延長して折る

透視図

後ろの層に入れる

すぐ後ろへ折り込む

紙を引き出して  
被せる

透視図



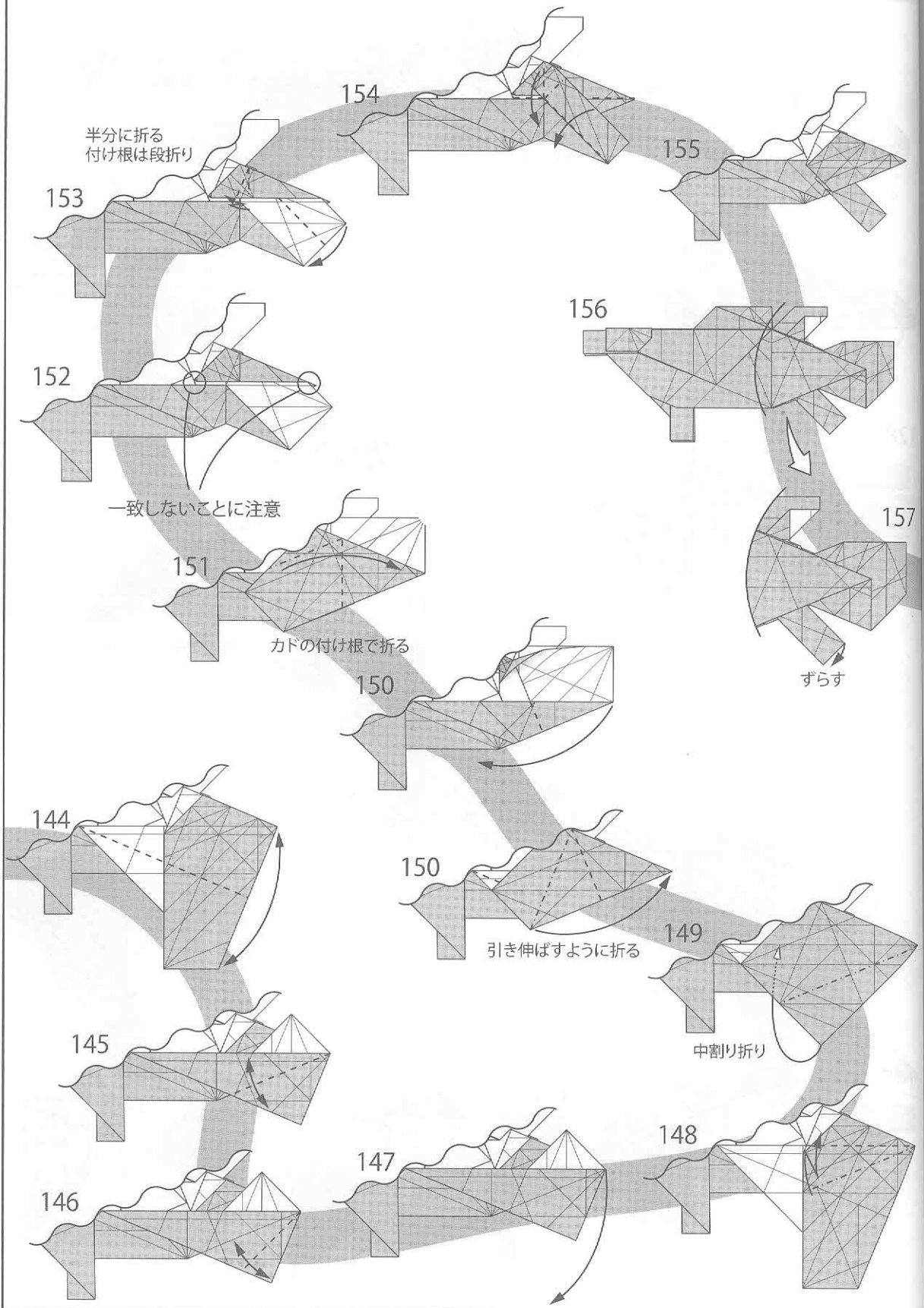

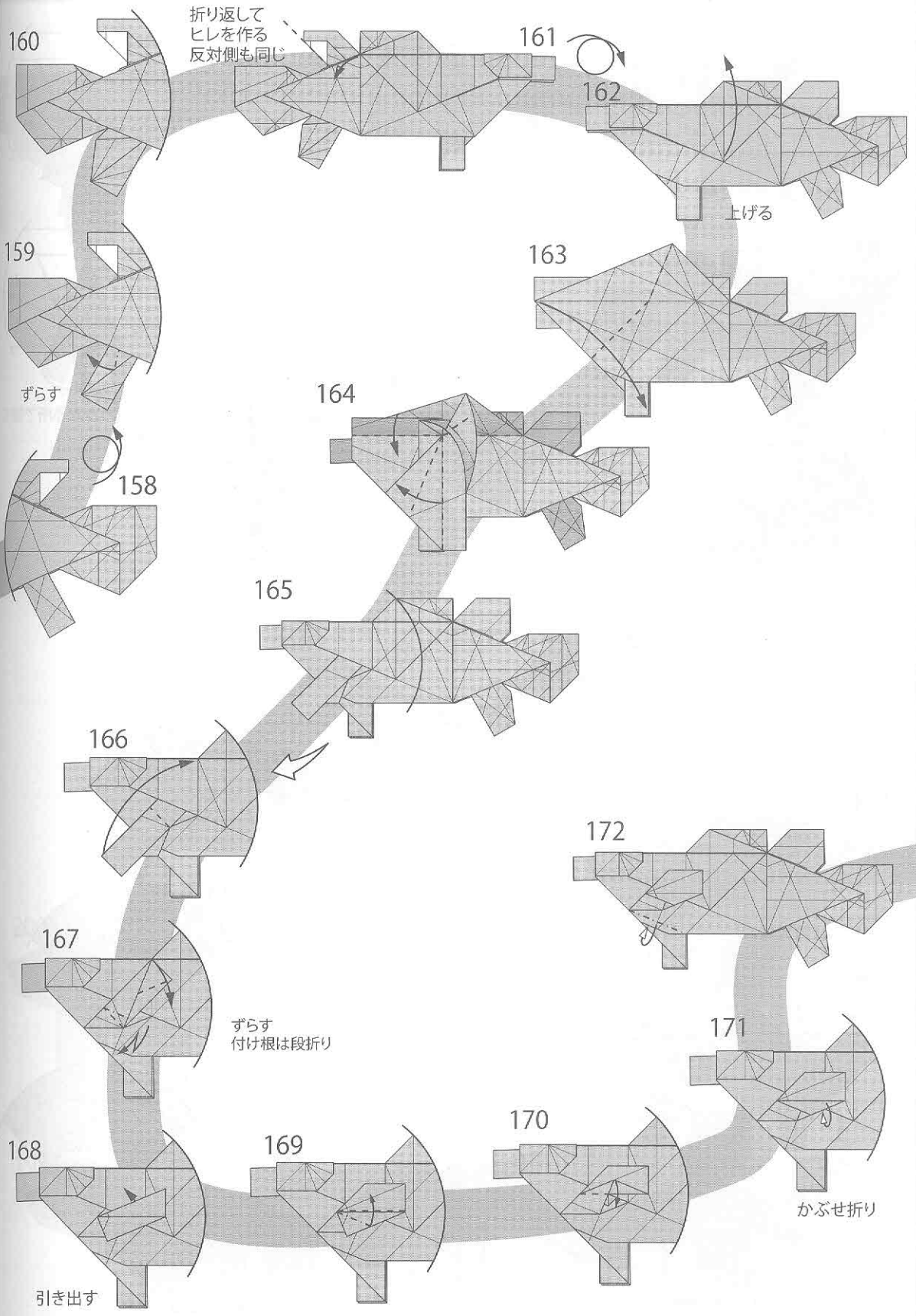

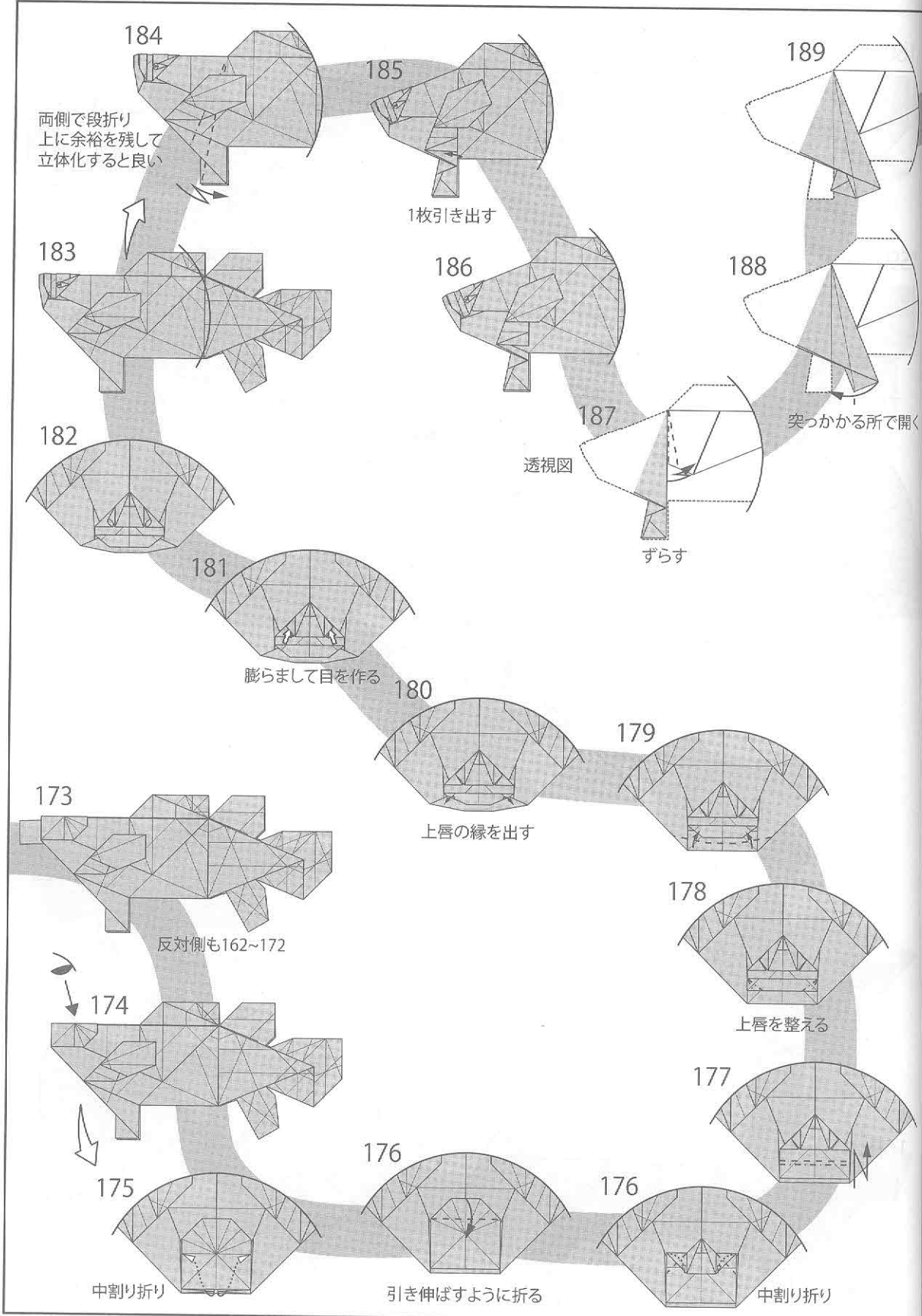



# ティーバッグのカエル Tea-bag Frog

創作：2013/1/10 作図：2013/5/9

小野友彰 (By Tomoaki ONO)

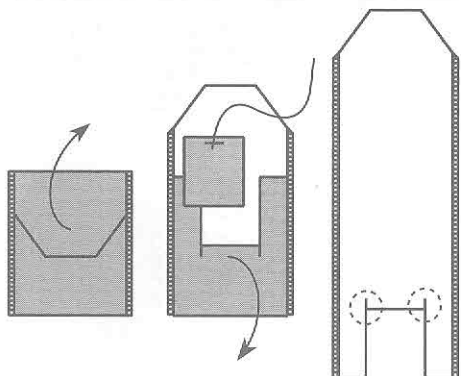

左右の圧着部は  
綺麗に切取る。

根元に3~4mm  
の切込みがある  
タイプが好適。  
但し、これがな  
くても折れます

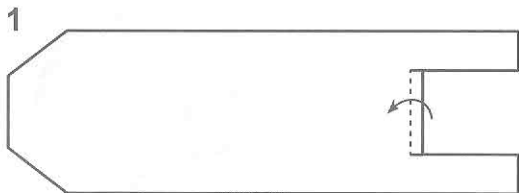

切込みがない場合は2から始める

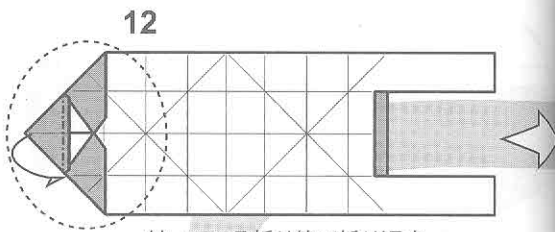
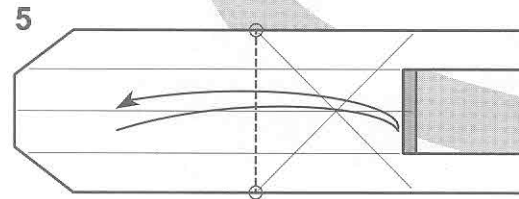
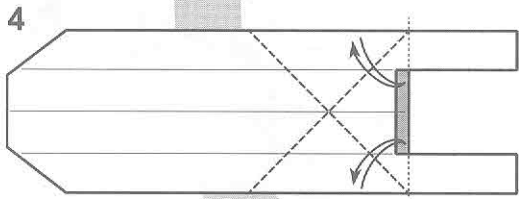
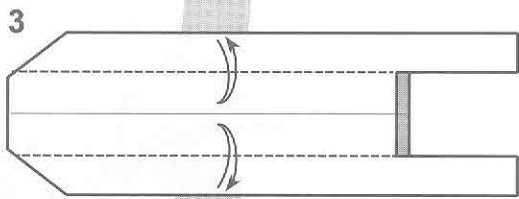
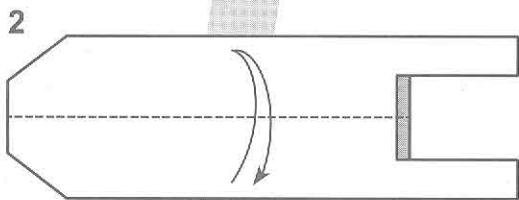

付いている折り筋で折り返す  
(次図は破線部分の拡大図)

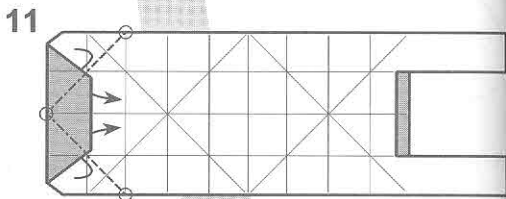

中割り折り(2ヶ所)

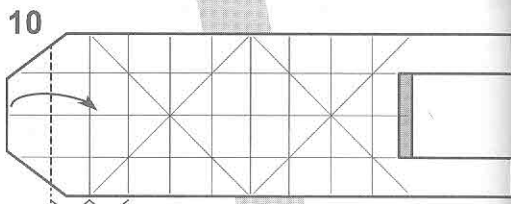

同じ幅のところで折り返す。  
この位置は、包み紙ごとに誤差が出るが  
気にせずに進めて問題ない(はず)。

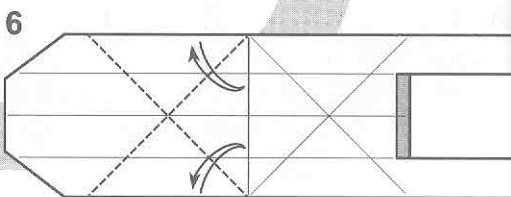
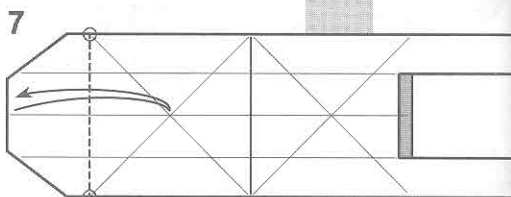
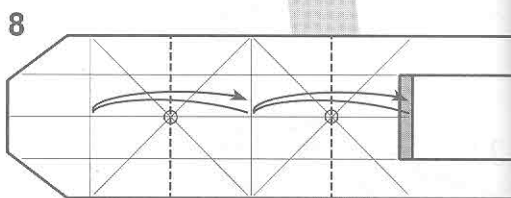
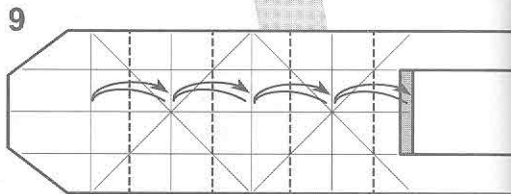

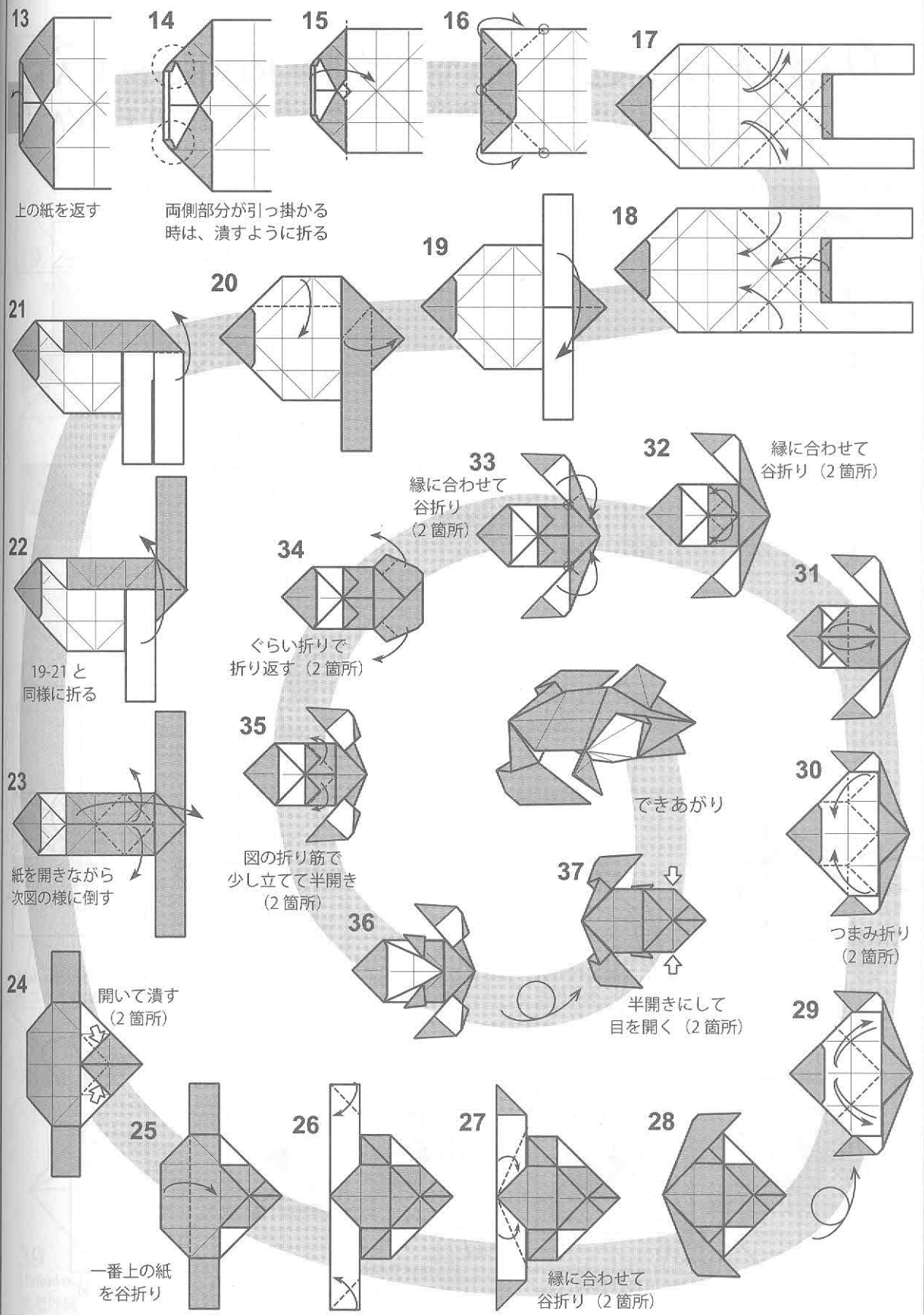

上の紙を返す

両側部分が引っ掛かる時は、潰すように折る

19-21 と同様に折る

紙を開きながら次図の様に倒す

開いて潰す (2箇所)

一番上の紙を谷折り

33 縁に合わせて谷折り (2箇所)

34 ぐらい折りで折り返す (2箇所)

35 図の折り筋で少し立てて半開き (2箇所)

できあがり

37 半開きにして目を開く (2箇所)

32 縁に合わせて谷折り (2箇所)

31 つまみ折り (2箇所)

28 縁に合わせて谷折り (2箇所)

# りぼんねこ

松井 英里香

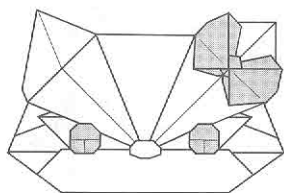

# RIBBON CAT MATSUI ERIKA

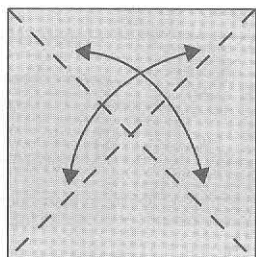

1

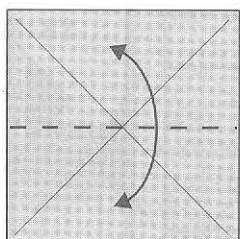

2

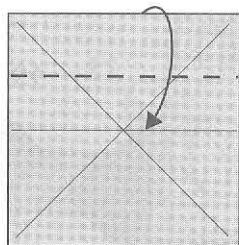

3

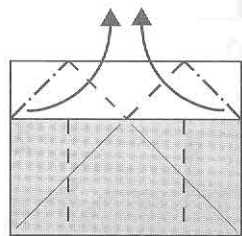

4 Rabbit ear.

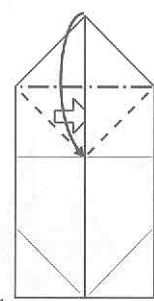

5 Squash fold both.  
四角につぶす

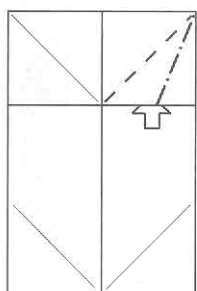

6 Squash fold.  
つぶす

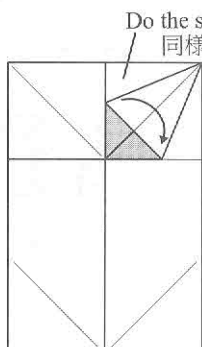

7 Fold the layer to the right.  
めくってたおす

Do the same.  
同様

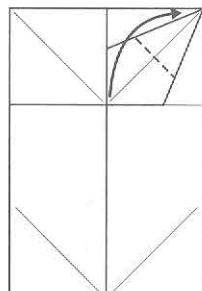

8 Fold the corner up while squash folding.  
かどを持ち上げて図のようにつぶす

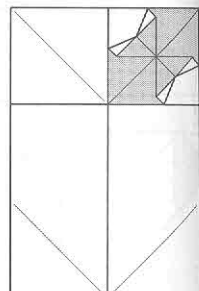

9

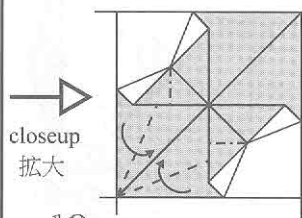

closeup  
拡大

10 Fold like reverse-fold.  
中割折りのように折る

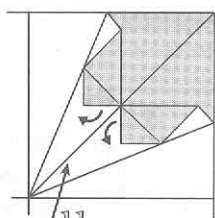

11 Pull out a little.  
少し引き出す

Cover all the color here.  
隙間があかないように

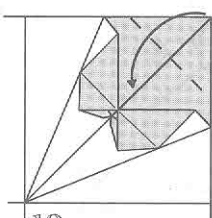

12 Fold as indicated.  
ぐらい折り

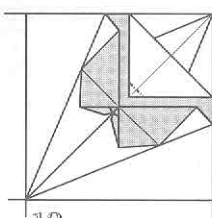

13 Fold the corner a little.  
先を少し折り込む

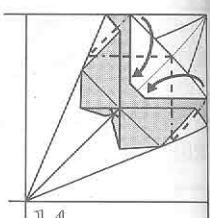

14 Fold like reverse-fold.  
中割折りのように折る

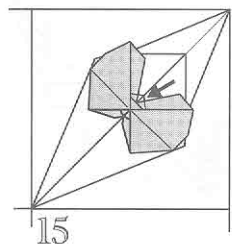

15 Fold a little as indicated.  
少し折り込む

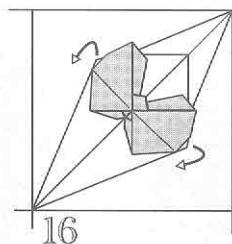

16 Fold to hide white parts  
out of the ribbon.  
白いところを隠す

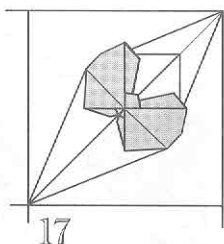

17 Finished Ribbon.  
りぼん完成

Finish  
closeup

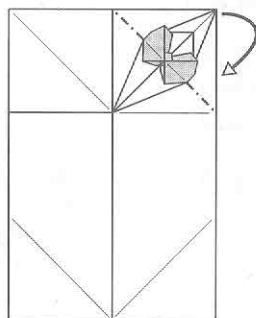

18 Mountain fold.

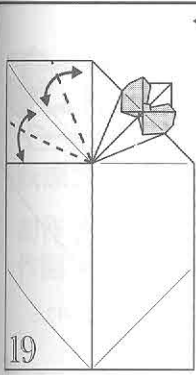

19

Fold and unfold.

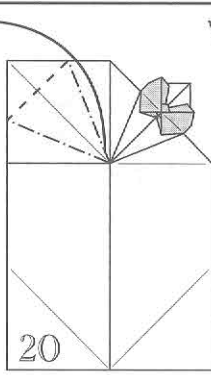

20

Petal fold.  
花弁折り

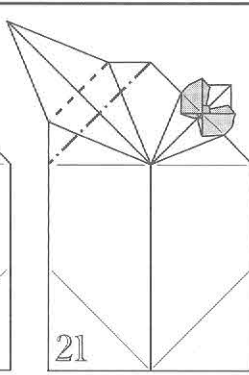

21

Pleat. 段折り

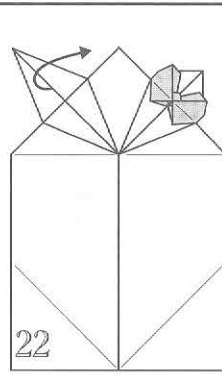

22

Unfold & flatten.

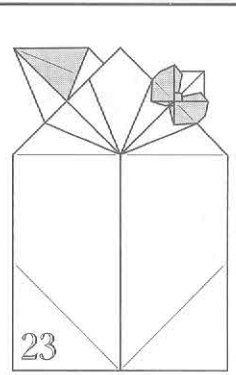

23

Repeat on the left.  
反対側も同じ

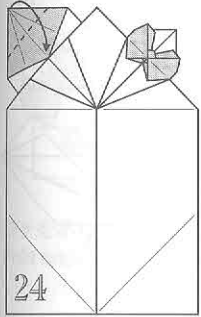

24

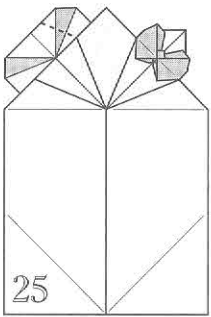

25

Fold along existing crease.  
既についているおりすじ  
を使って折る

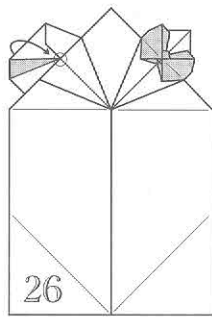

26

Fold the edge  
to the point.  
ふちが点を通る  
ように折る

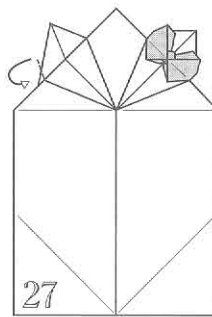

27

Fold along existing crease.  
既についているおりすじ  
を使って折る

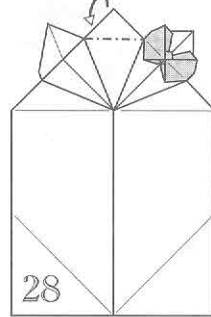

28

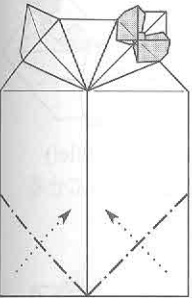

29 Reverse fold both.  
両方とも中割折り

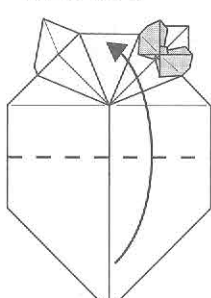

30

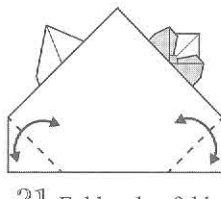

31 Fold and unfold.

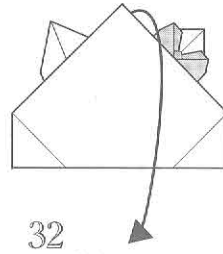

32 Unfold.

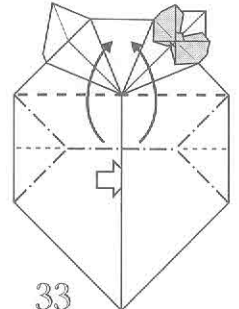

33

Fold the flaps up as indicated.  
横から押してひだをつくる

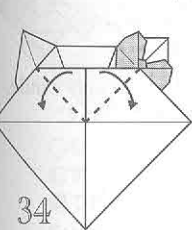

34

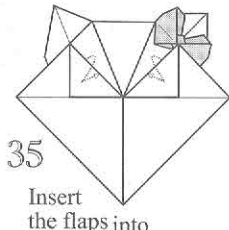

35

Insert  
the flaps into  
the pockets  
ポケットにしまう

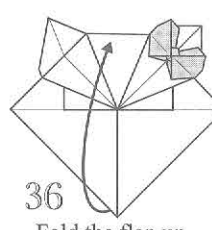

36

Fold the flap up.  
一枚めくる

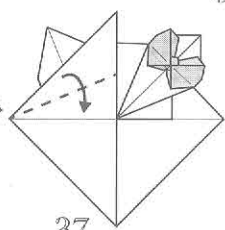

37

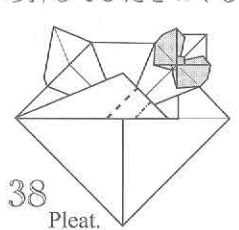

38

Pleat.  
1/3の幅で段折り

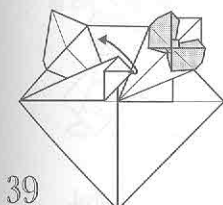

39

Unfold only the tip  
先だけ開く

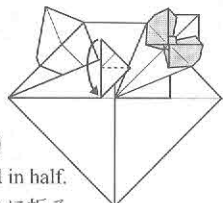

40

Fold in half.  
半分に折る

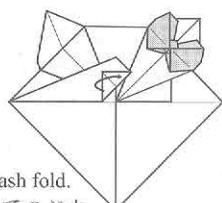

41

Squash fold.  
開いてつぶす

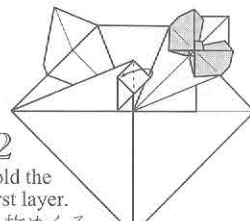

42

Fold the  
first layer.  
一枚めくる



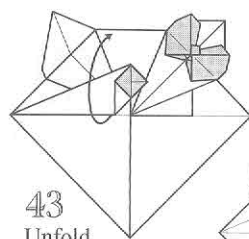

43 Unfold.

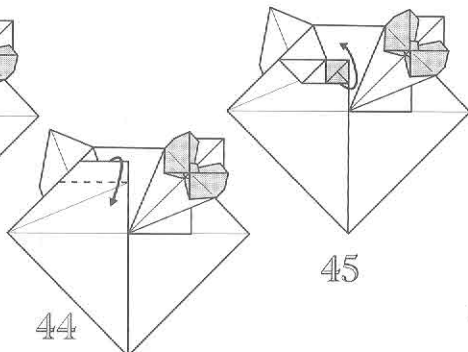

44

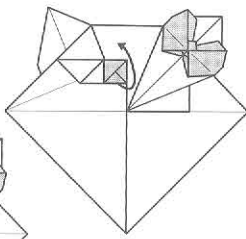

45

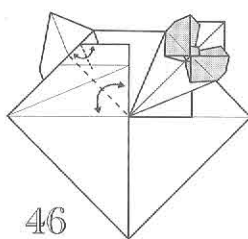

46 Fold and unfold. x2  
図のようにおりすじをつける

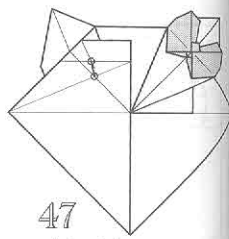

47 点と点を  
結ぶ線をつける

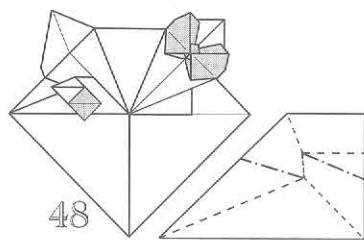

48 Insert the layer  
into the pocket.  
ポケットにしまう

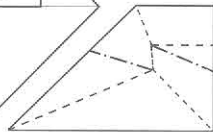

47 48  
in progress...  
このように折りたたむ

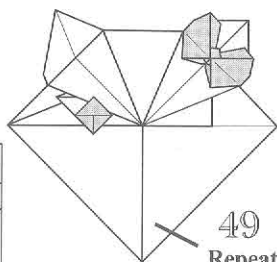

49 Repeat.  
反対側も同じ

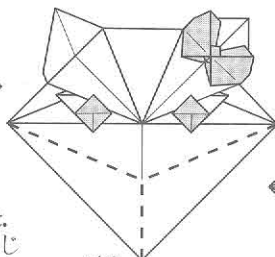

50 Rabbit ear.

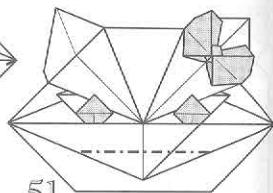

51 Open sink.

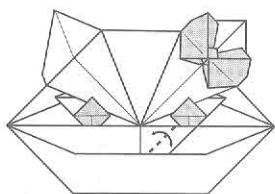

52 Fold and unfold.

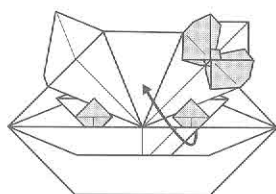

53 Fold the flap up  
while squash folding.  
上に向けてつぶす

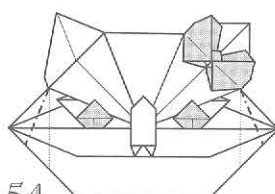

54 Mountain fold as indicated.  
図の位置で折り込む

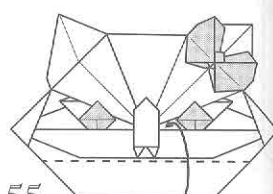

55 (cover the line a little!)  
下の線に少しかぶせるとよい

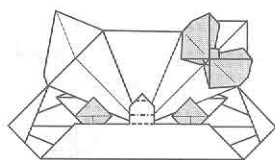

56 Pleats.  
段折り

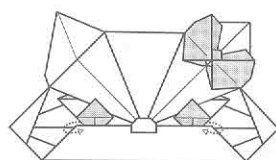

57 Pull out the layers.  
引き出す

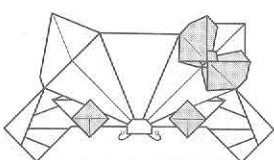

58 Fold a little.  
少しけずる

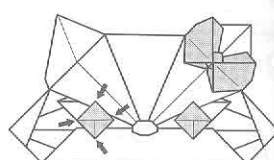

59 Fold the corners a little.  
四隅を折り込む

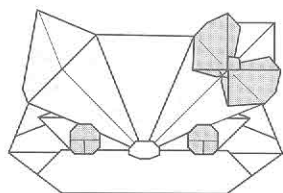

62 Completed  
できあがり

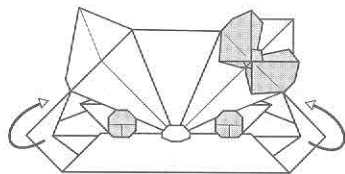

61 Fold the flaps behind.  
向こう側に折る

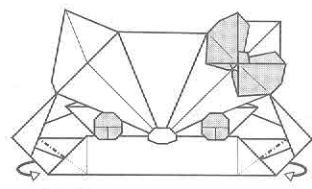

60 Mountain fold as indicated.  
図の位置で折り込む

# にわとり Rooster

萩原元 / Gen Hagiwara

創作 / Model

11/2012

作図 / Diagram

04/2013

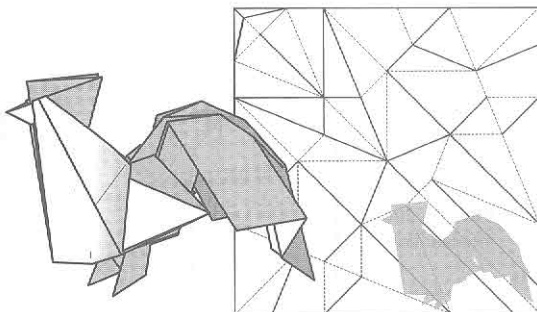

Rooster by Gen Hagiwara

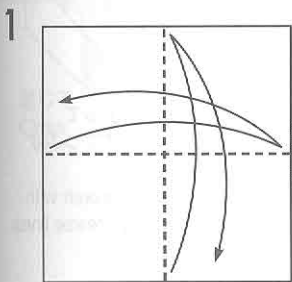

フチをあわせて半分に折り筋をつける  
Fold edges to edges and unfold.

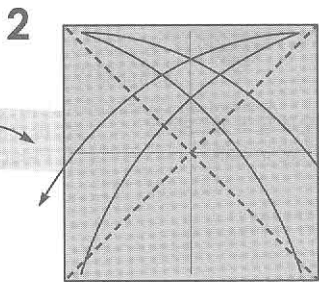

対角線に折り筋をつける  
Fold diagonals and unfold.

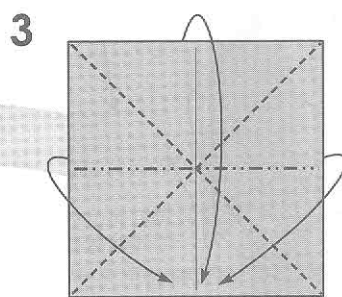

折り筋をつかってたたむ  
Collapse with existing crease lines.

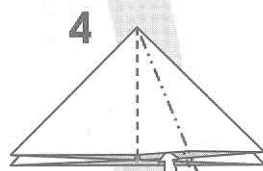
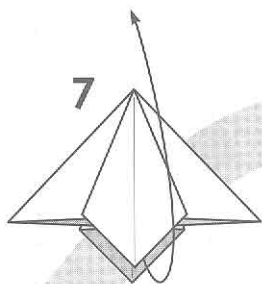

内側をひろげて  
つぶすように折る  
Open and squash.

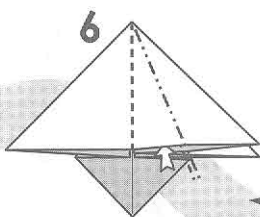

内側をひろげて  
つぶすように折る  
Open and squash.

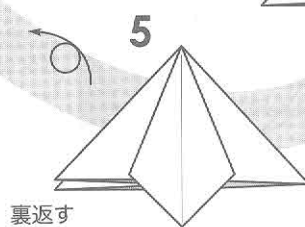

裏返す  
Turn over.

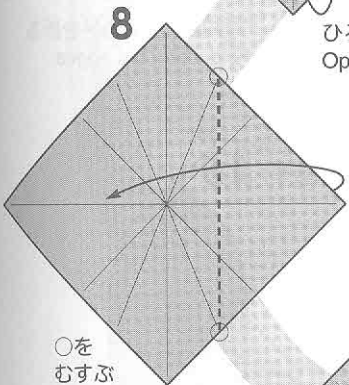

○を  
むすぶ  
線で折る  
Fold the corner  
at circled points.

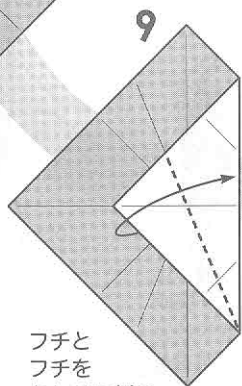

フチと  
フチを  
あわせて折る  
Fold edge to edge.

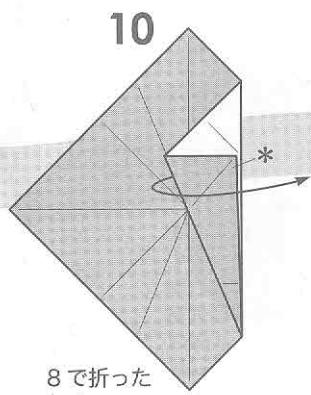

8で折った  
部分を開く  
Open the fold.

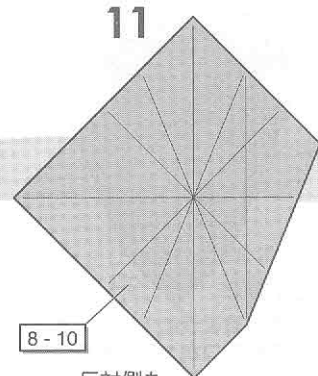

8-10  
反対側も  
8-10と同様に折る  
Repeat 8-10 on left side.

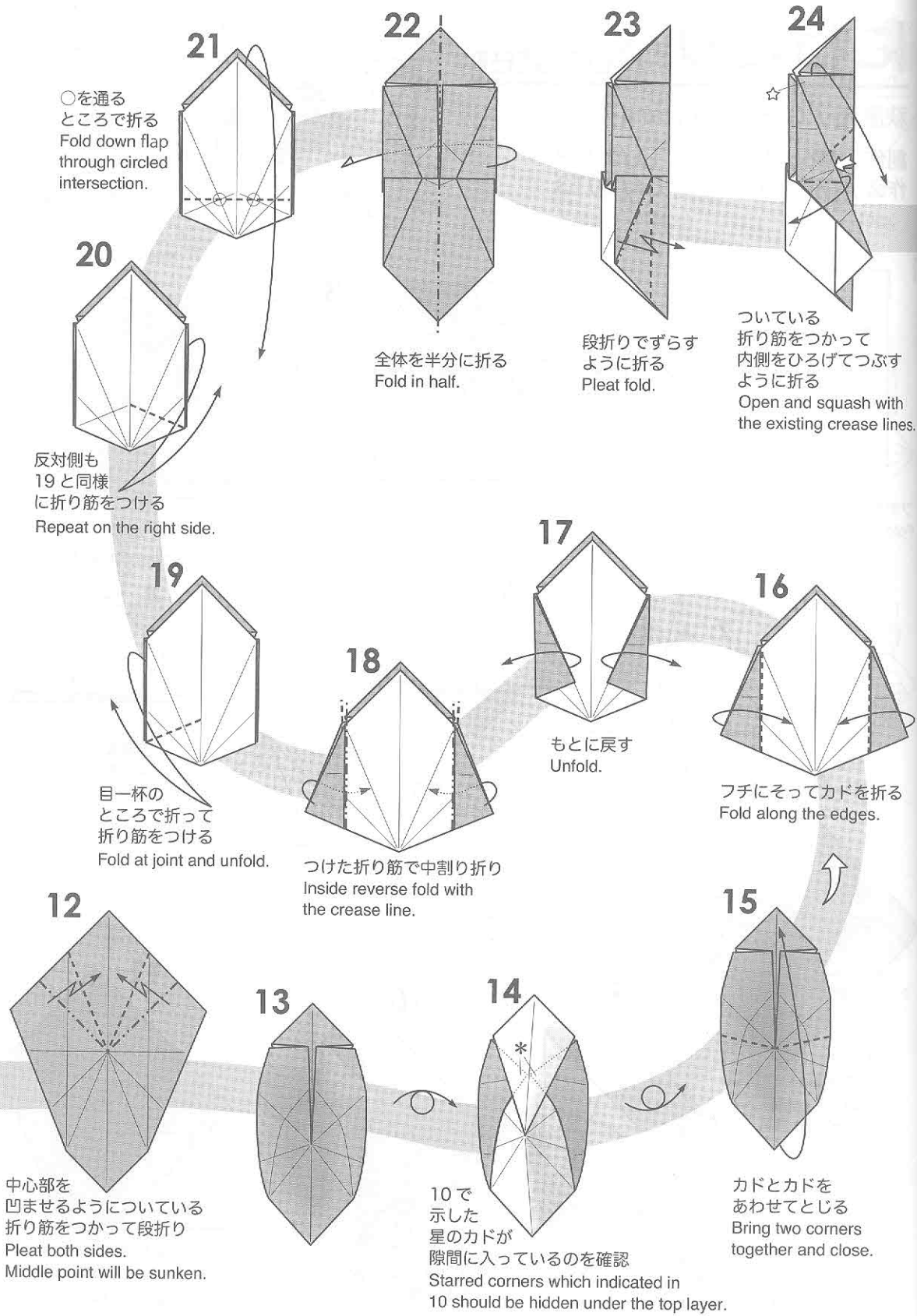

○を通る  
ところを折る  
Fold down flap  
through circled  
intersection.

反対側も  
19と同様に  
折り筋をつける  
Repeat on the right side.

目一杯の  
ところで折って  
折り筋をつける  
Fold at joint and unfold.

中心部を  
凹ませるように  
折り筋をつか  
って段折り  
Pleat both sides.  
Middle point will be sunken.

全体を半分  
に折る  
Fold in half.

段折り  
でずらす  
ように折る  
Pleat fold.

ついている  
折り筋をつか  
って内側を  
ひろげてつ  
ぶすように  
折る  
Open and squ  
ash with the  
existing crease  
lines.

もとに戻す  
Unfold.

つけた折り筋  
で中割り折  
り  
Inside reverse  
fold with the  
crease line.

フチにそって  
カドを折る  
Fold along the  
edges.

10で  
示した  
星のカドが  
隙間に入っ  
ているのを  
確認  
Starred corners  
which indicated  
in 10 should be  
hidden under the  
top layer.

カドとカドを  
あわせてと  
じる  
Bring two corners  
together and close.

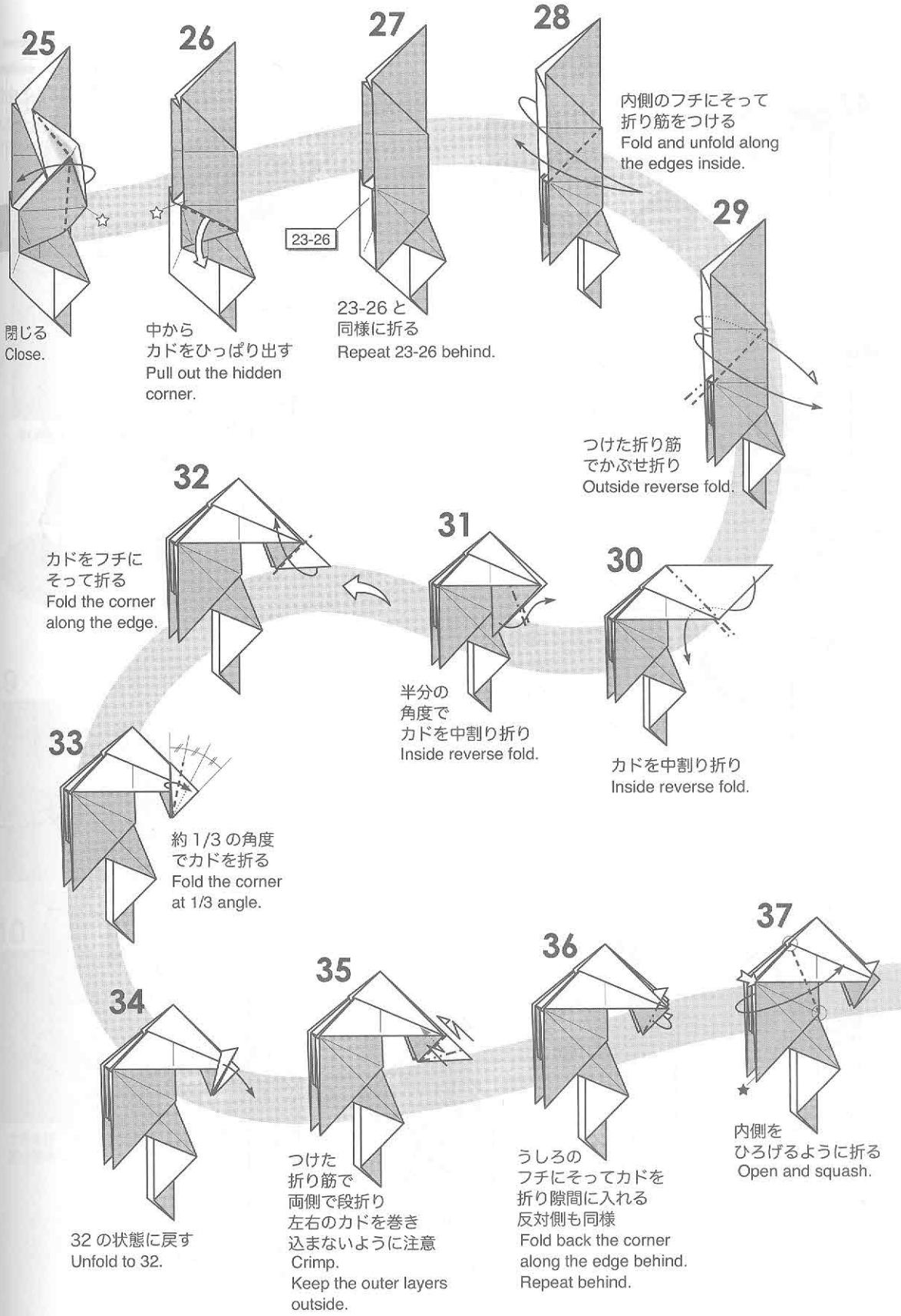

**25**  
閉じる  
Close.

**26**  
中から  
カドをひっぱり出す  
Pull out the hidden  
corner.

**27**  
23-26 と  
同様に折る  
Repeat 23-26 behind.

**28**  
内側のフチにそって  
折り筋をつける  
Fold and unfold along  
the edges inside.

**29**  
つけた折り筋  
でかぶせ折り  
Outside reverse fold.

**32**  
カドをフチに  
そって折る  
Fold the corner  
along the edge.

**31**  
半分の  
角度で  
カドを中割り折り  
Inside reverse fold.

**30**  
カドを中割り折り  
Inside reverse fold.

**33**  
約 1/3 の角度  
でカドを折る  
Fold the corner  
at 1/3 angle.

**34**  
32 の状態に戻す  
Unfold to 32.

**35**  
つけた  
折り筋で  
両側で段折り  
左右のカドを巻き  
込まないように注意  
Crimp.  
Keep the outer layers  
outside.

**36**  
うしろの  
フチにそってカドを  
折り隙間に入れる  
反対側も同様  
Fold back the corner  
along the edge behind.  
Repeat behind.

**37**  
内側を  
ひろげるように折る  
Open and squash.

47

両側で段折り  
Pleat both side.

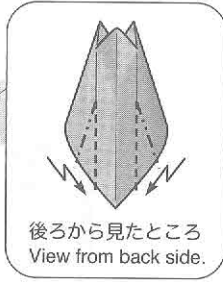
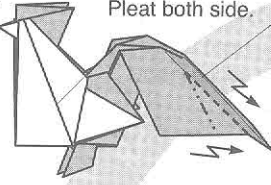

後ろから見たところ  
View from back side.

48

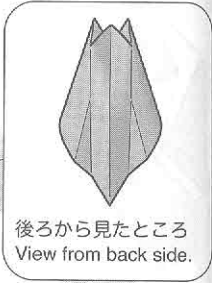
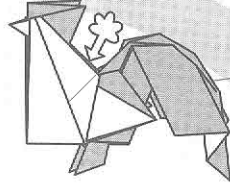

後ろから見たところ  
View from back side.

胴体を立体的に仕上げる  
Make the body three dimensional.

46

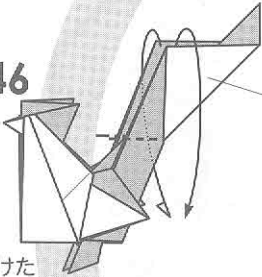

つけた  
折り筋をつかって  
ヒダをひろげつつ  
かぶせ折り  
Outside reverse fold.

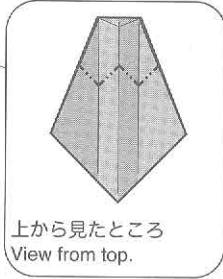

上から見たところ  
View from top.

49

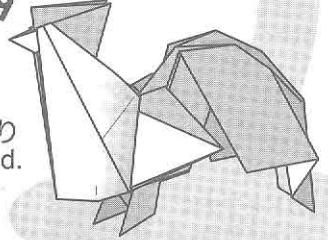

できあがり  
Completed.

45

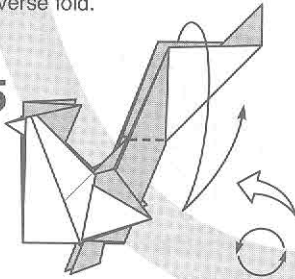

折り筋をつける  
Fold and unfold.

44

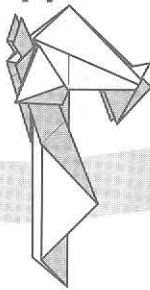

43

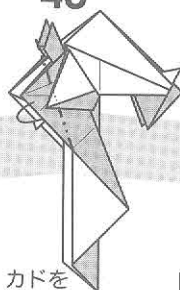

カドを  
うしろに折る  
反対側も同様  
Fold back the corner.  
Repeat behind.

42

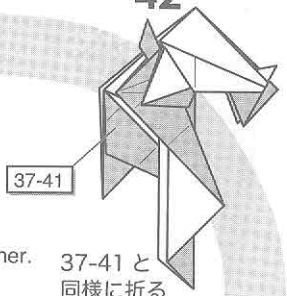

37-41 と  
同様に折る  
Repeat 37-41 behind.

38

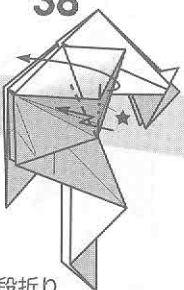

段折り  
しつつ閉じる  
Pleat the corner  
and close.

39

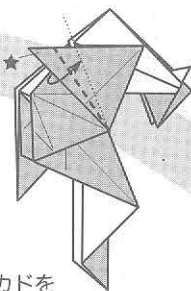

カドを  
半分の角度で折る  
Fold the corner at  
1/2 angle.

40

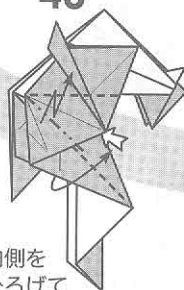

内側を  
ひろげて  
つぶすように折る  
Open and squash.

41

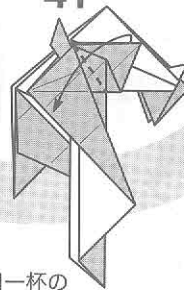

目一杯の  
ところでカドを折る  
Fold the corner.

# ニワトリ

神谷哲史

Model & Diagrams by Satoshi Kamiya

作 2011/12/xx

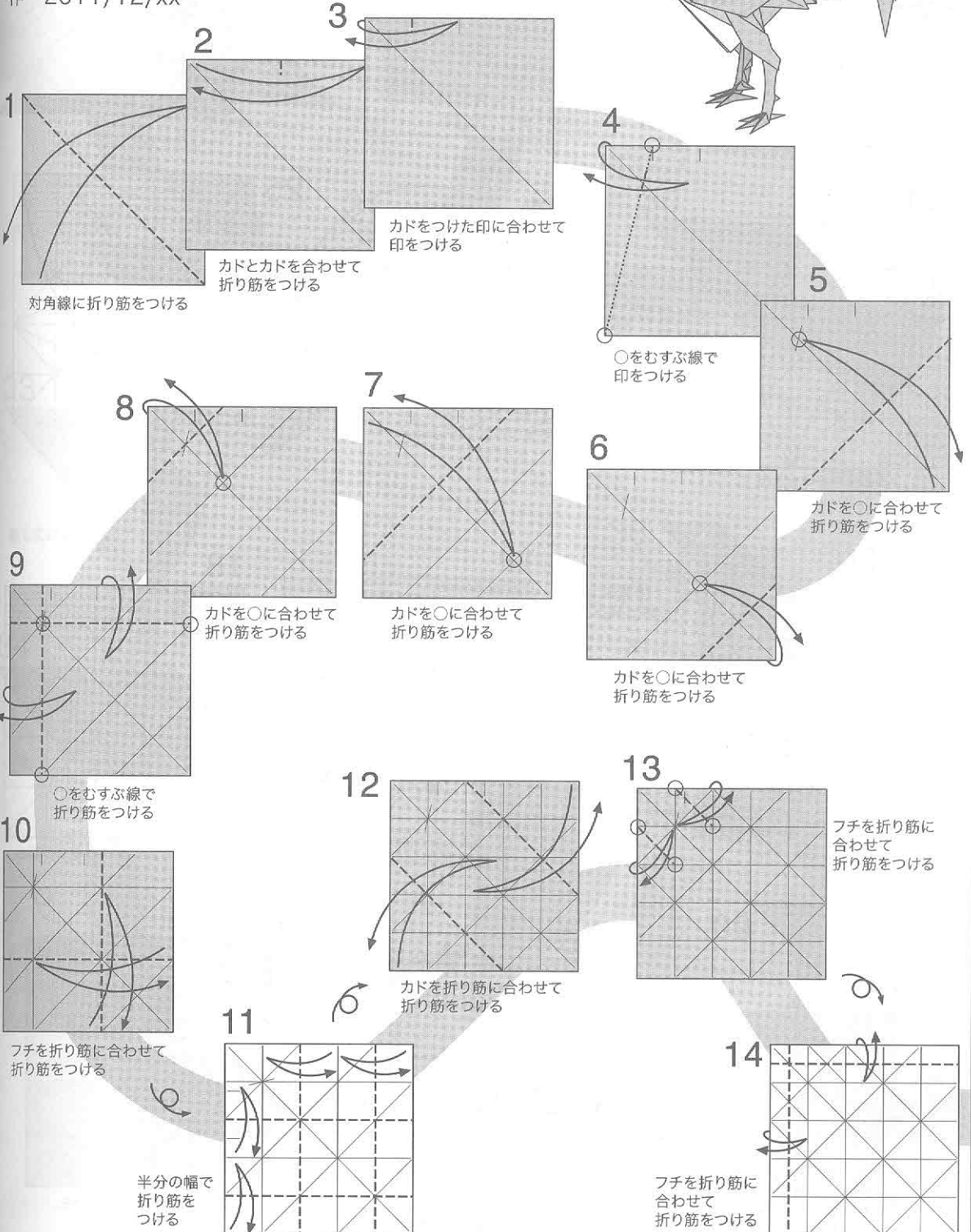

22

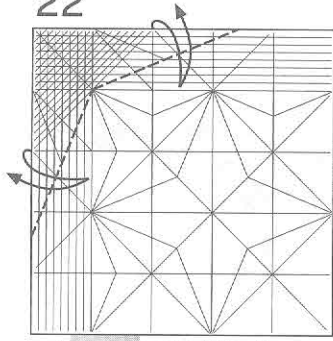

半分の角度で折り筋をつける

23

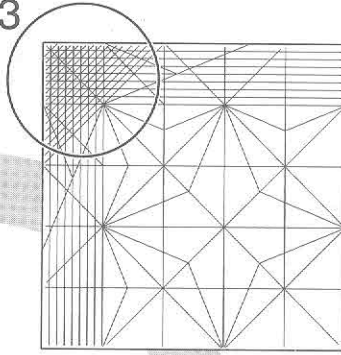

26

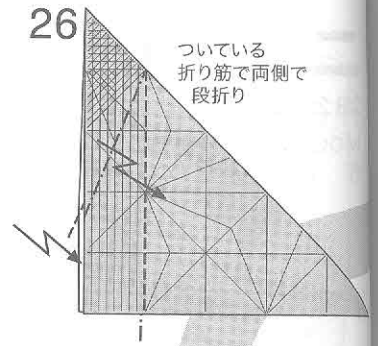

ついている  
折り筋で両側で  
段折り

21

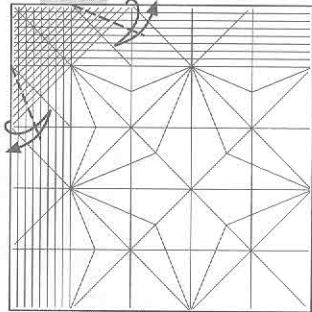

フチを折り筋に合わせて  
折り筋をつける

24

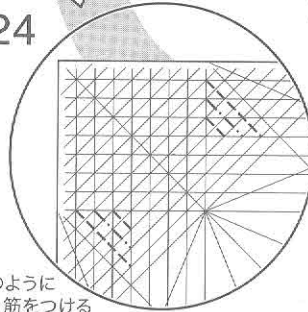

図のように  
折り筋をつける

25

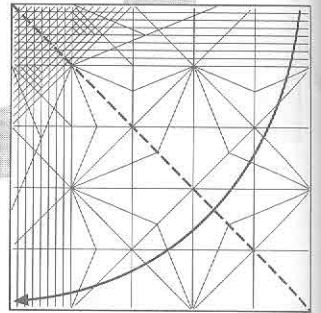

三角に折る

20

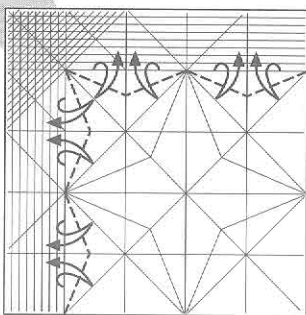

フチを折り筋に合わせて  
折り筋をつける

19

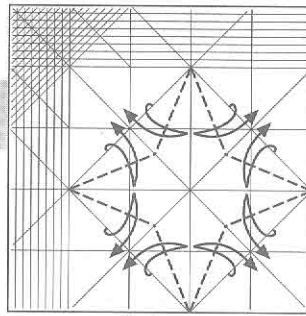

フチを折り筋に合わせて  
折り筋をつける

18

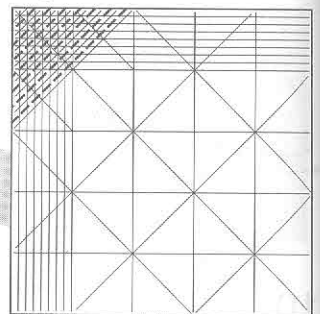

半分の幅で折り筋をつける

15

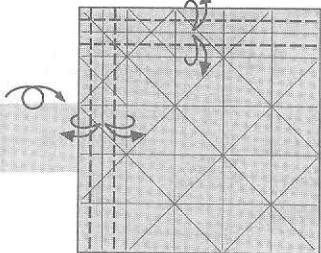

半分の幅で折り筋をつける

16

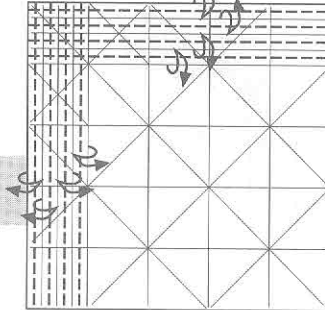

さらに半分の幅で折り筋をつける

17

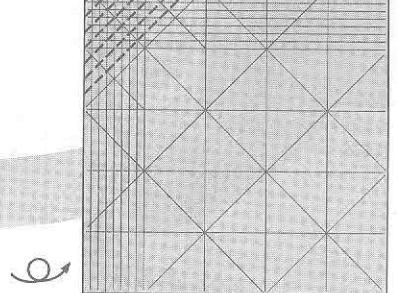

1/8の幅で折り筋をつける

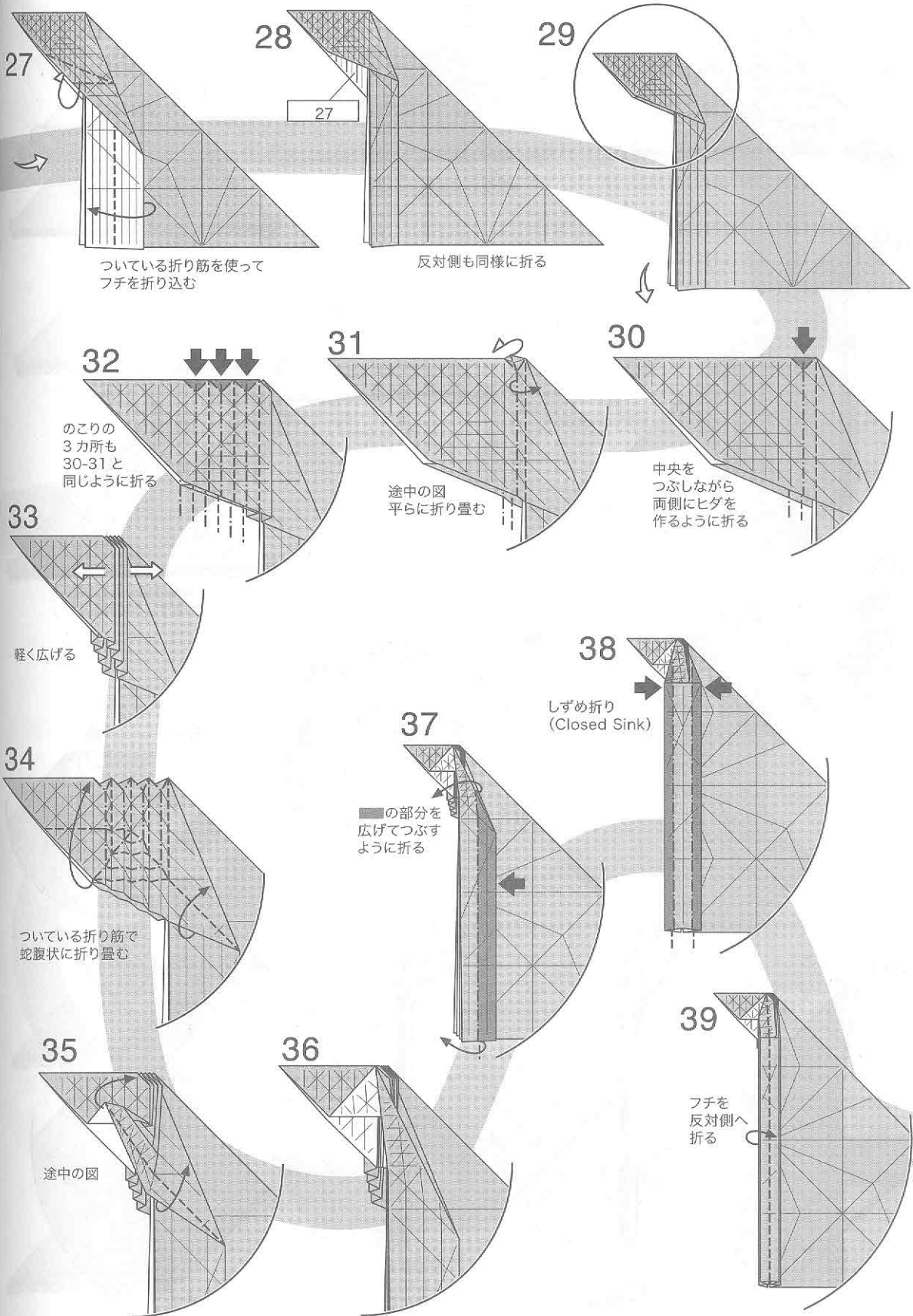



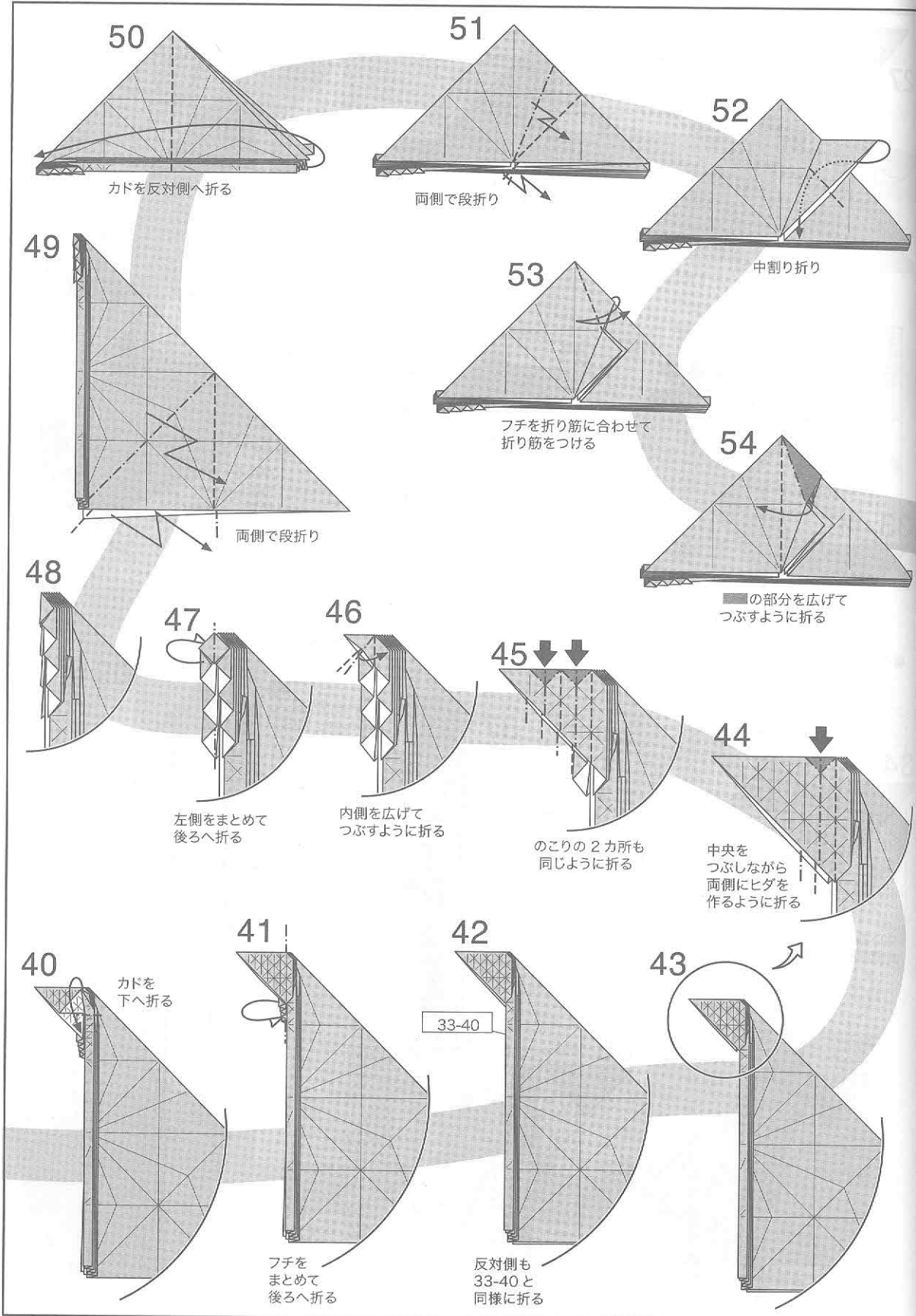

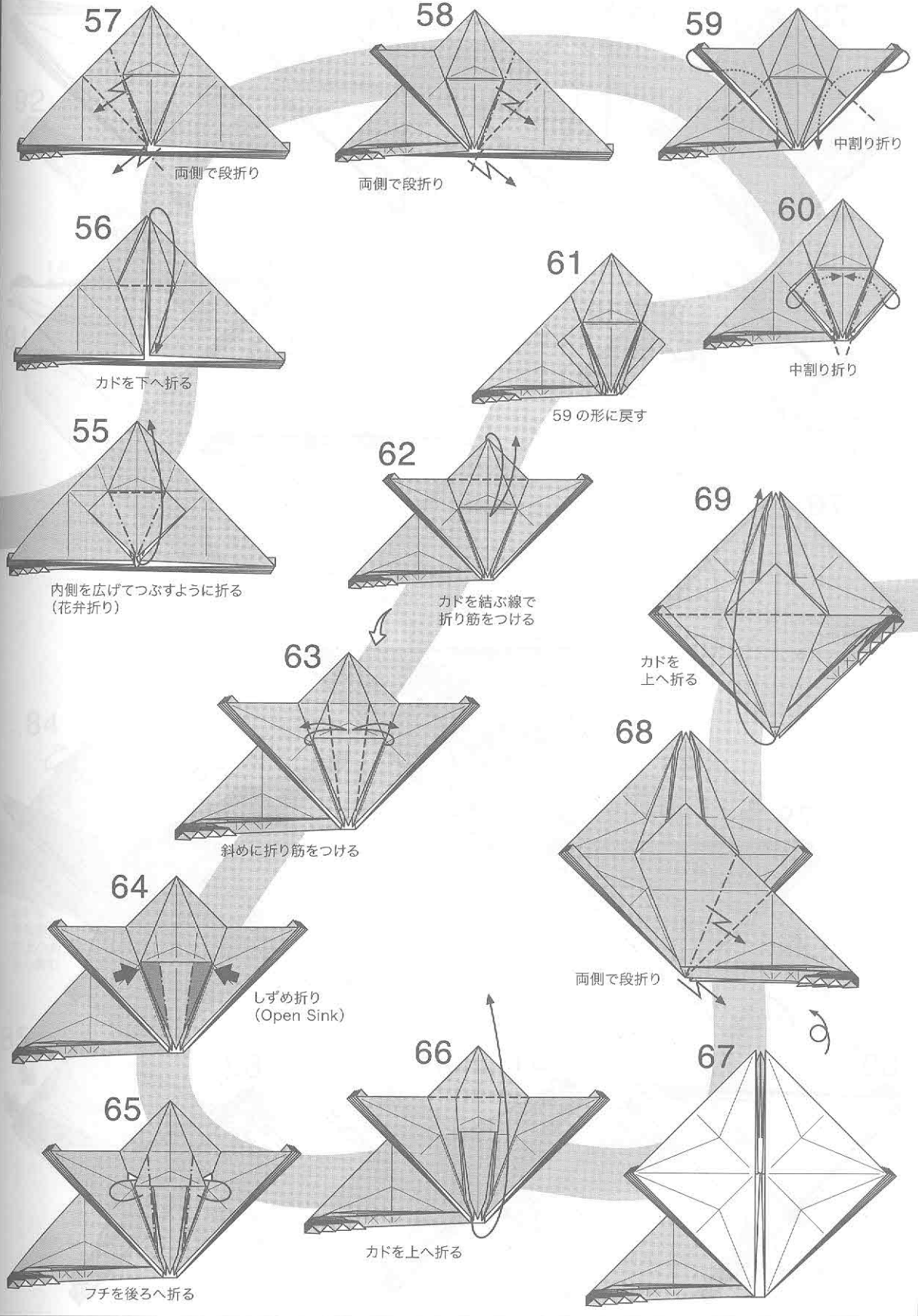

57

両側で段折り

58

両側で段折り

59

中割り折り

56

カドを下へ折る

61

59の形に戻す

60

中割り折り

55

内側を広げてつぶすように折る  
(花弁折り)

62

カドを結ぶ線で  
折り筋をつける

69

カドを  
上へ折る

63

斜めに折り筋をつける

68

両側で段折り

64

しずめ折り  
(Open Sink)

66

カドを上へ折る

65

フチを後ろへ折る

67

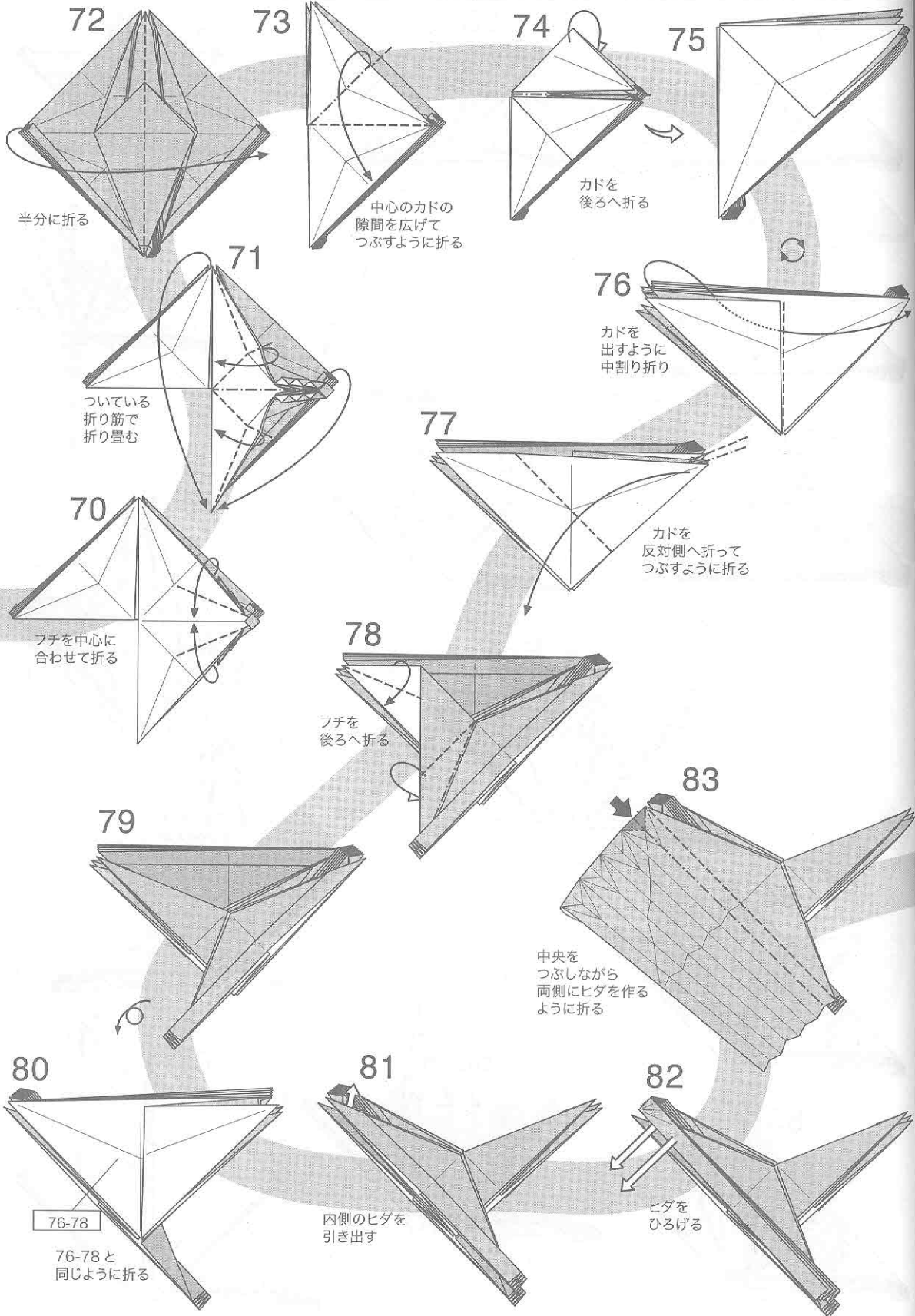

93

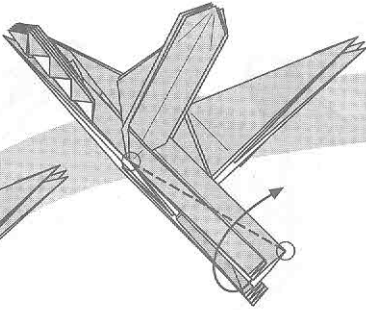

カドを○をむすぶ  
線で折る

94

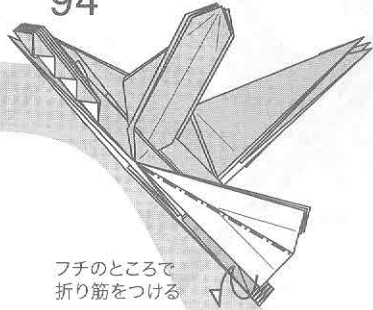

フチのところで  
折り筋をつける

92

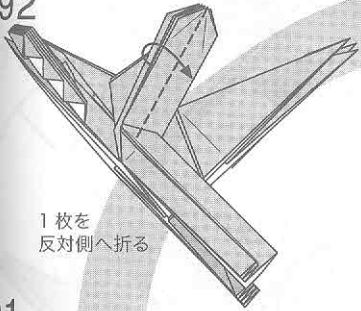

1枚を  
反対側へ折る

95

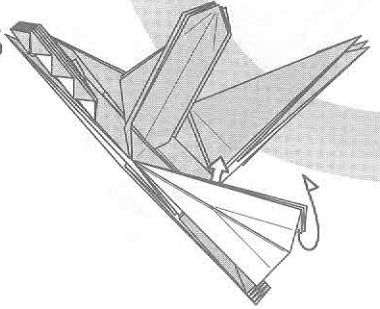

うしろのヒダを  
引き出す

91

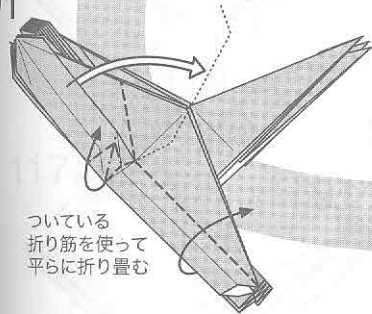

ついている  
折り筋を使って  
平らに折り畳む

90

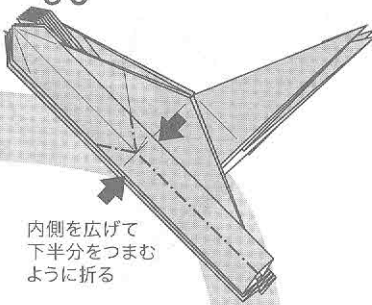

内側を広げて  
下半分をつまむ  
ように折る

89

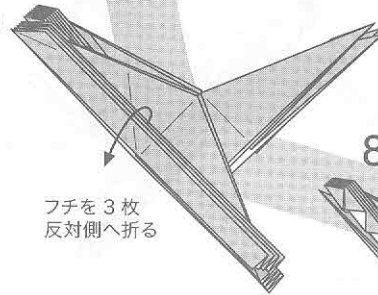

フチを3枚  
反対側へ折る

88

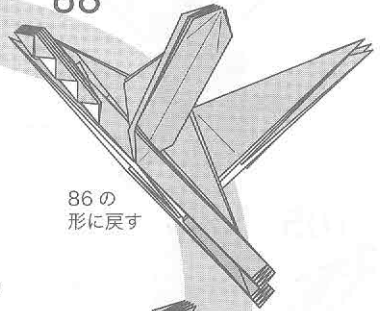

86の  
形に戻す

84

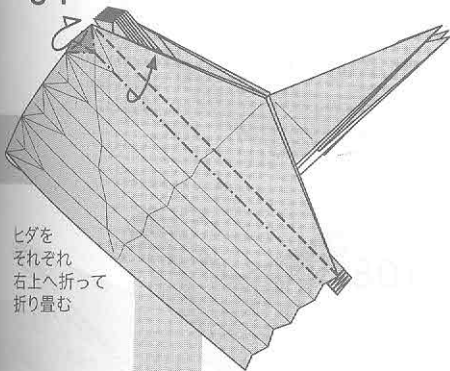

ヒダを  
それぞれ  
右上へ折って  
折り畳む

87

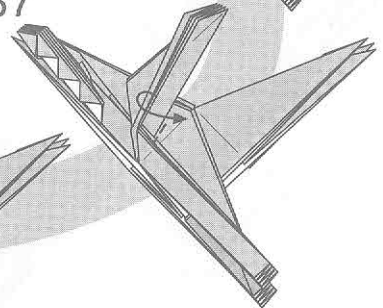

フチを1枚だけ  
反対側へ折る

85

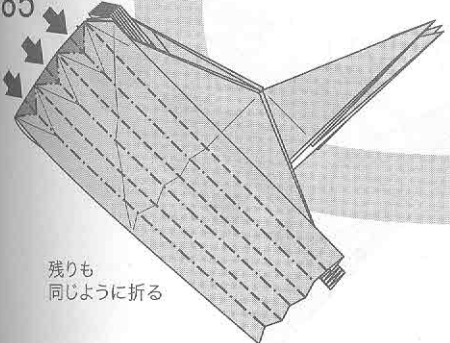

残りも  
同じように折る

86

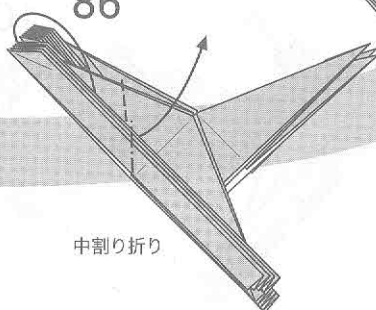

中割り折り

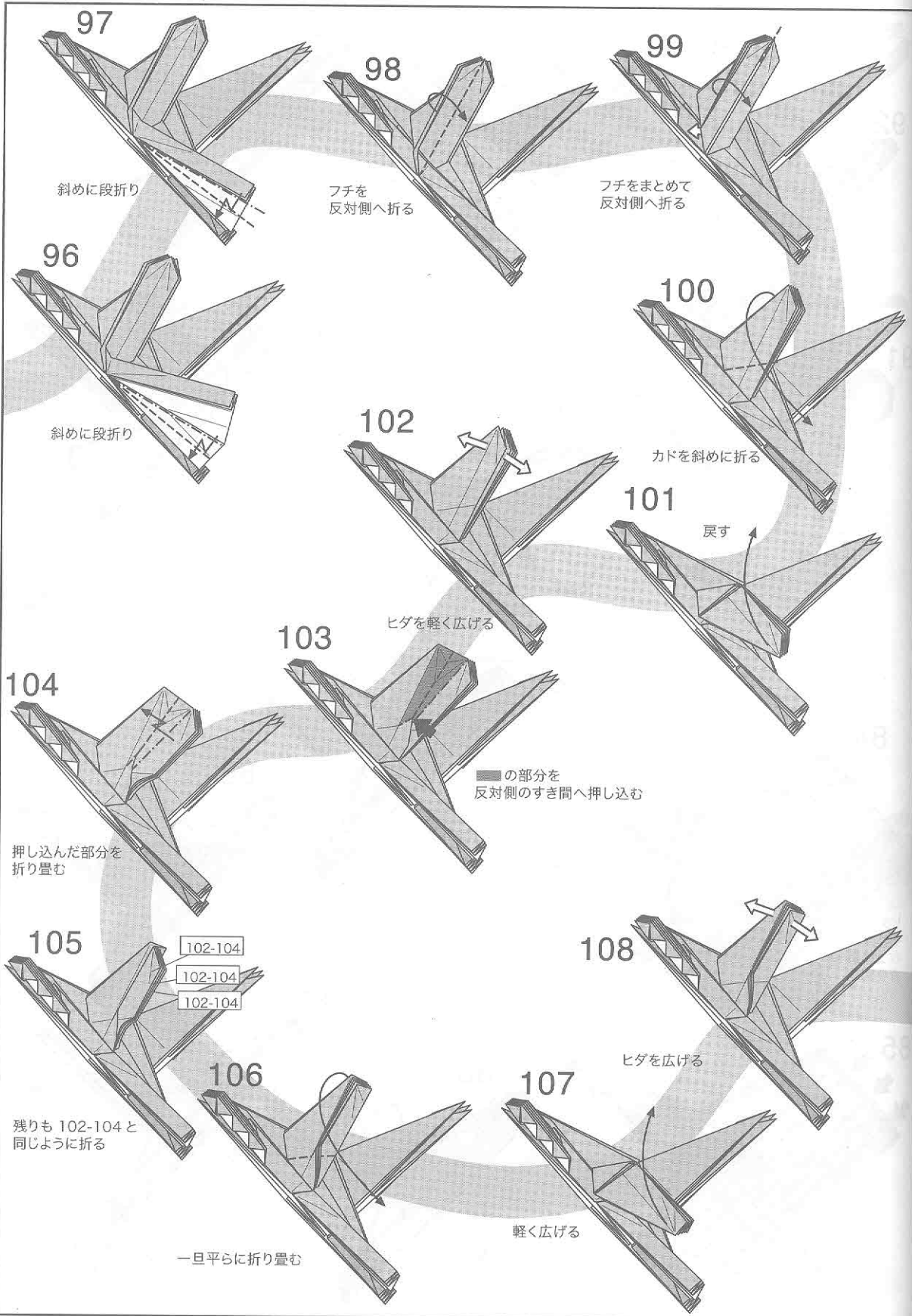

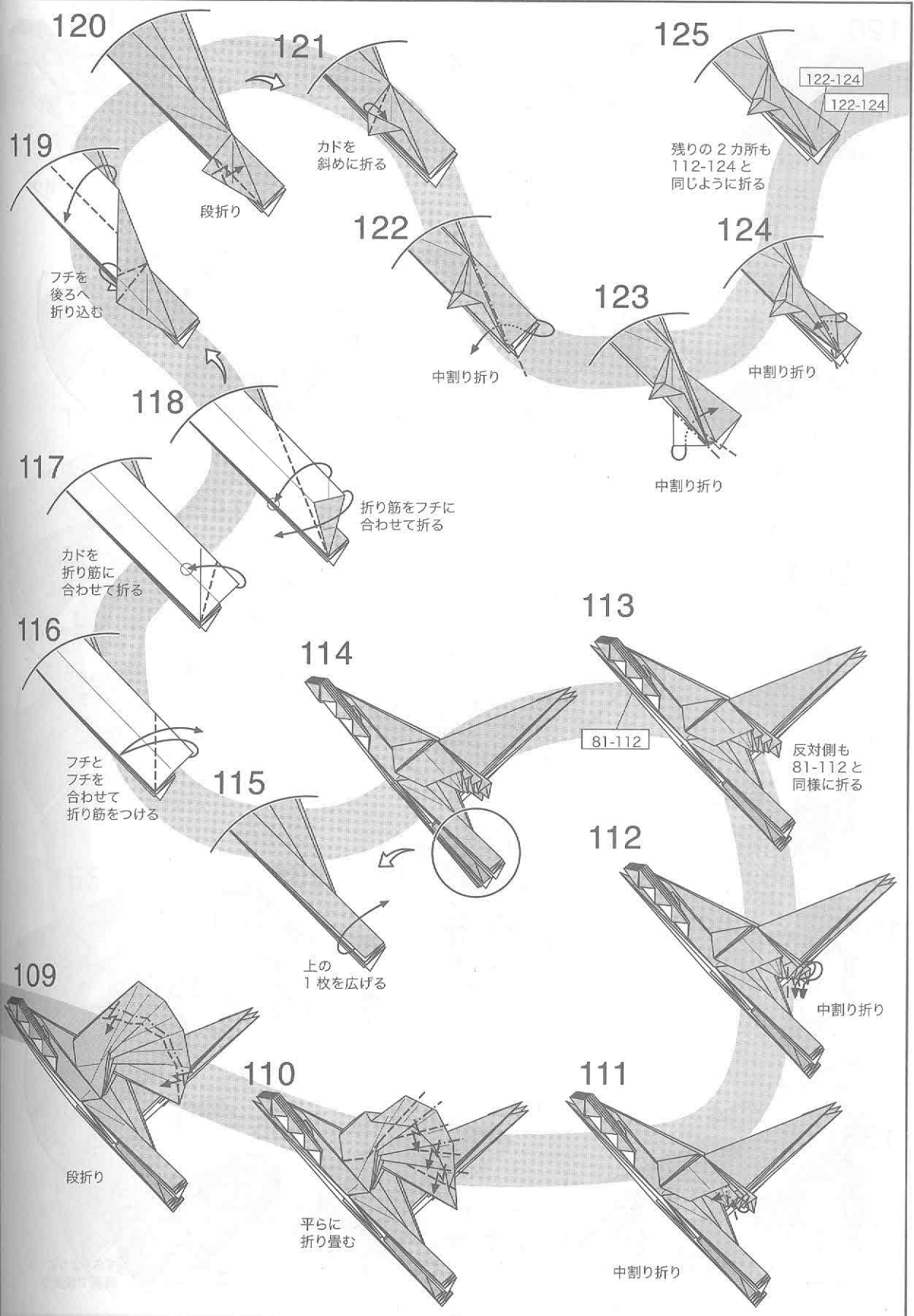

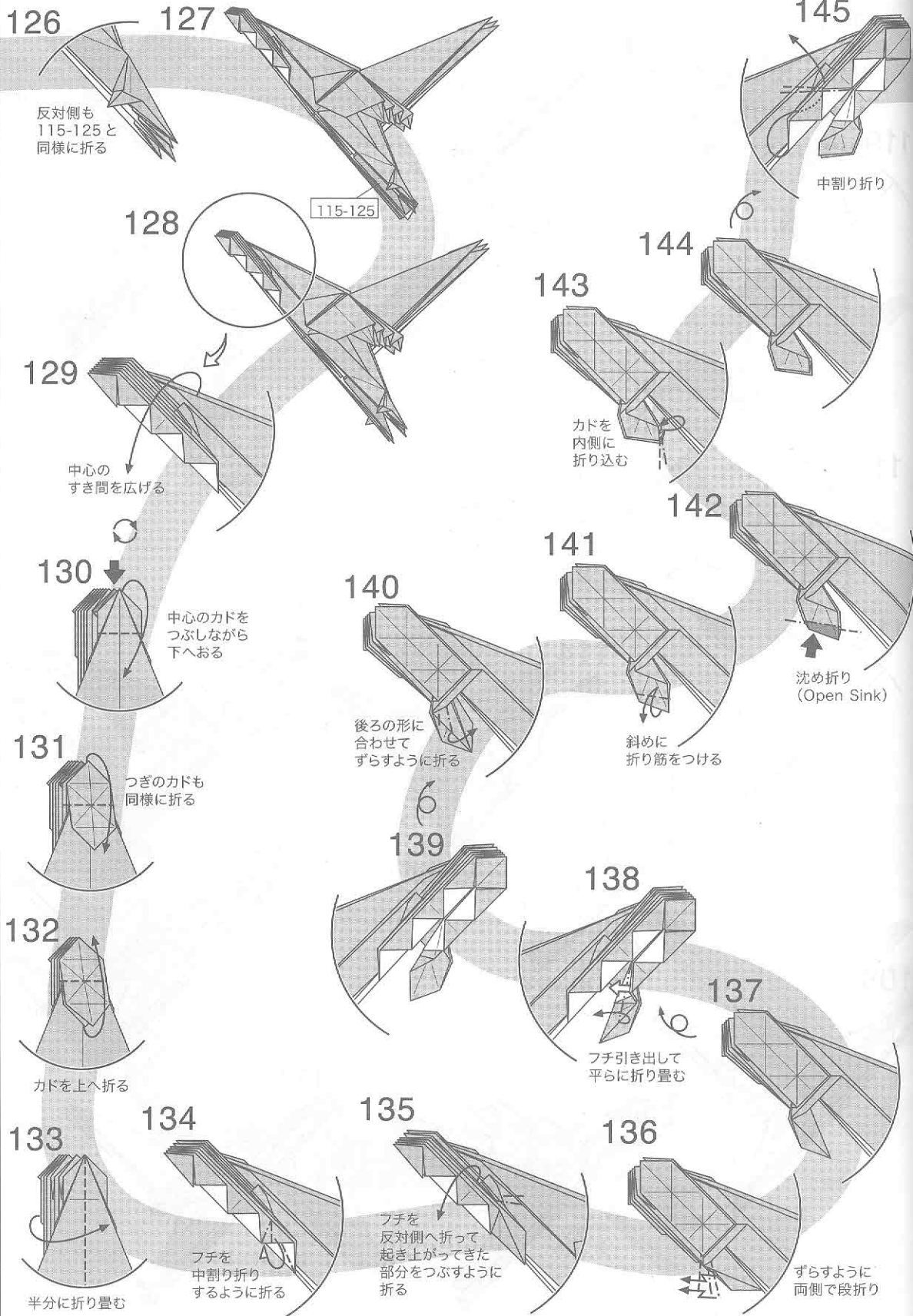

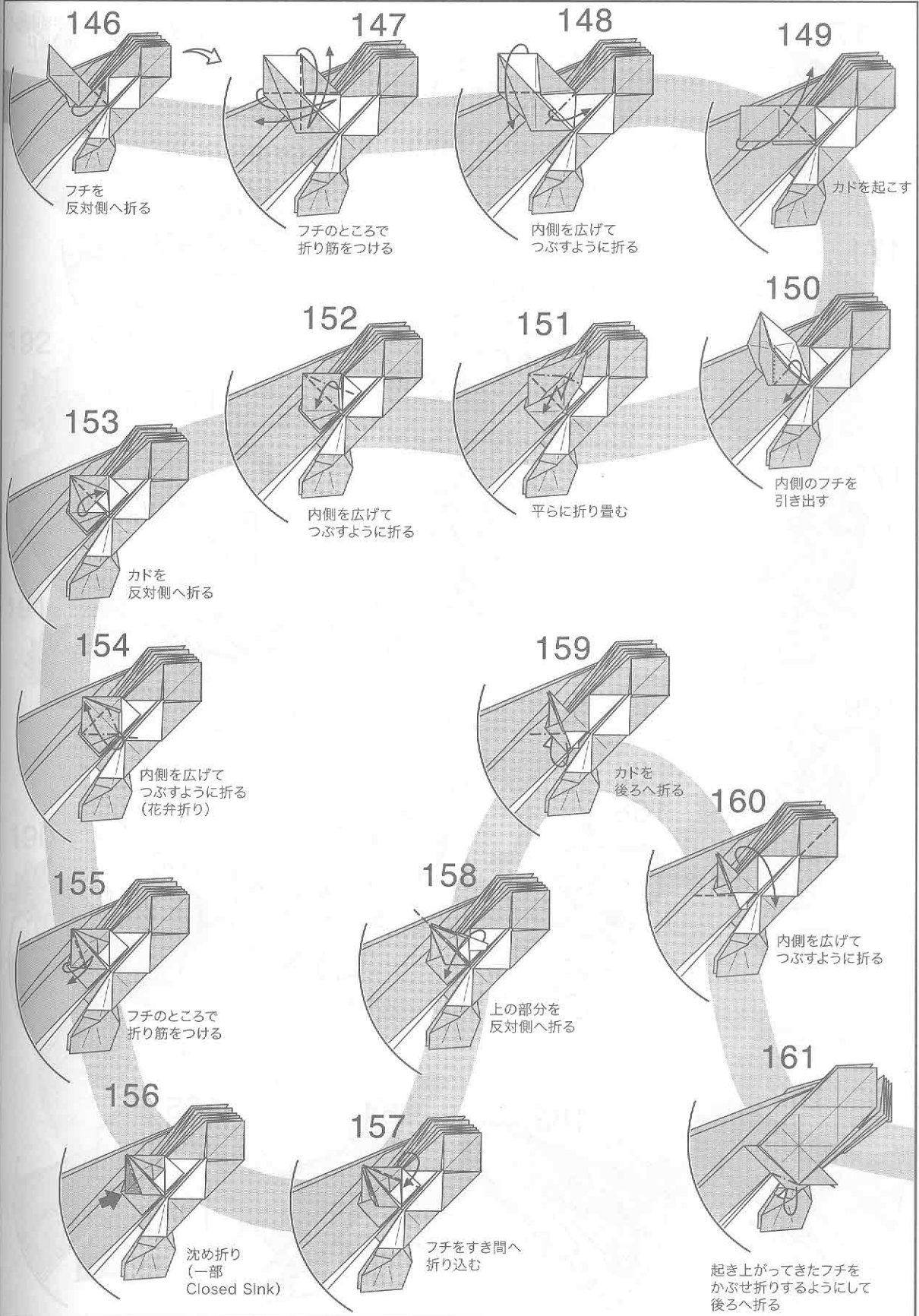



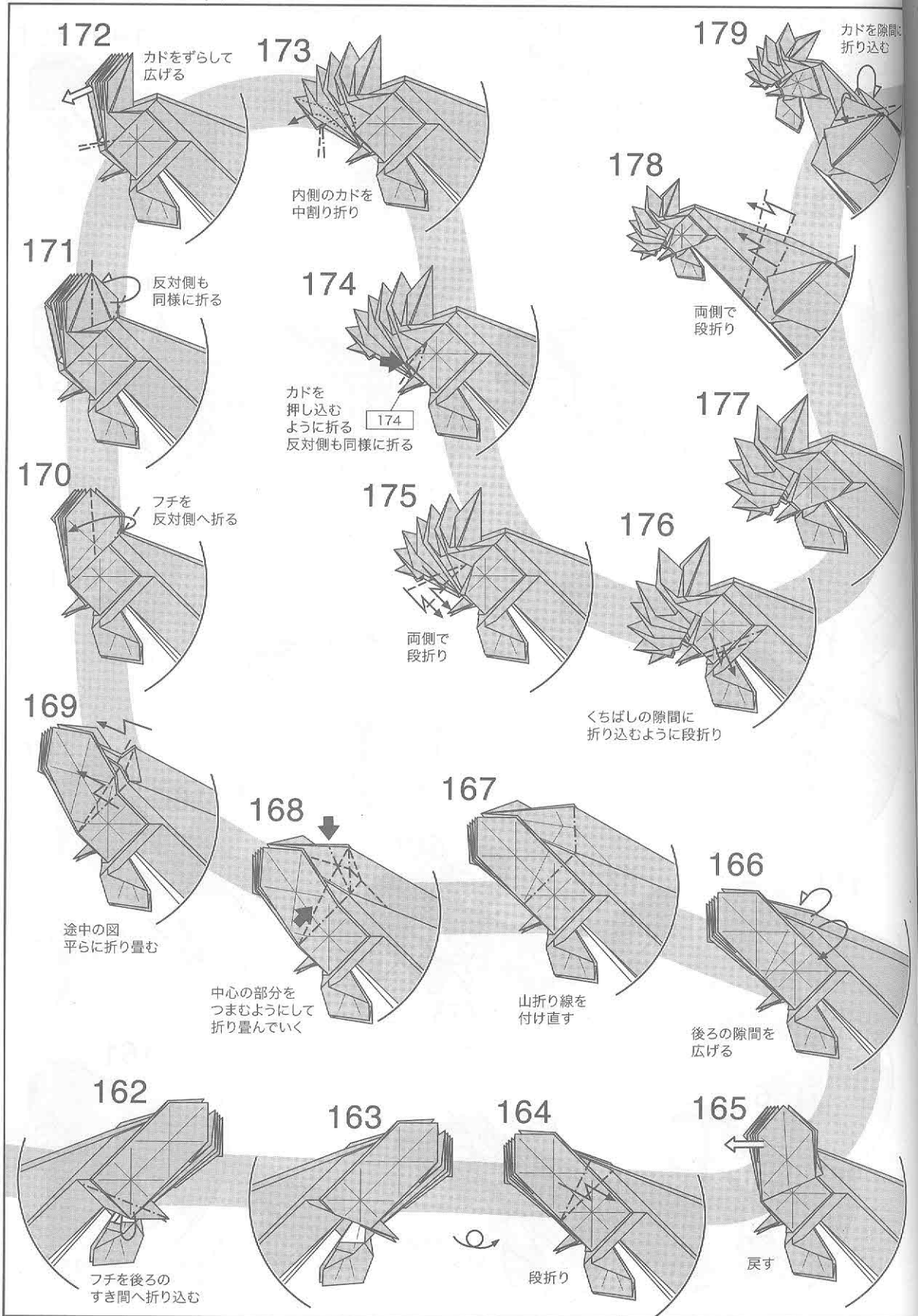

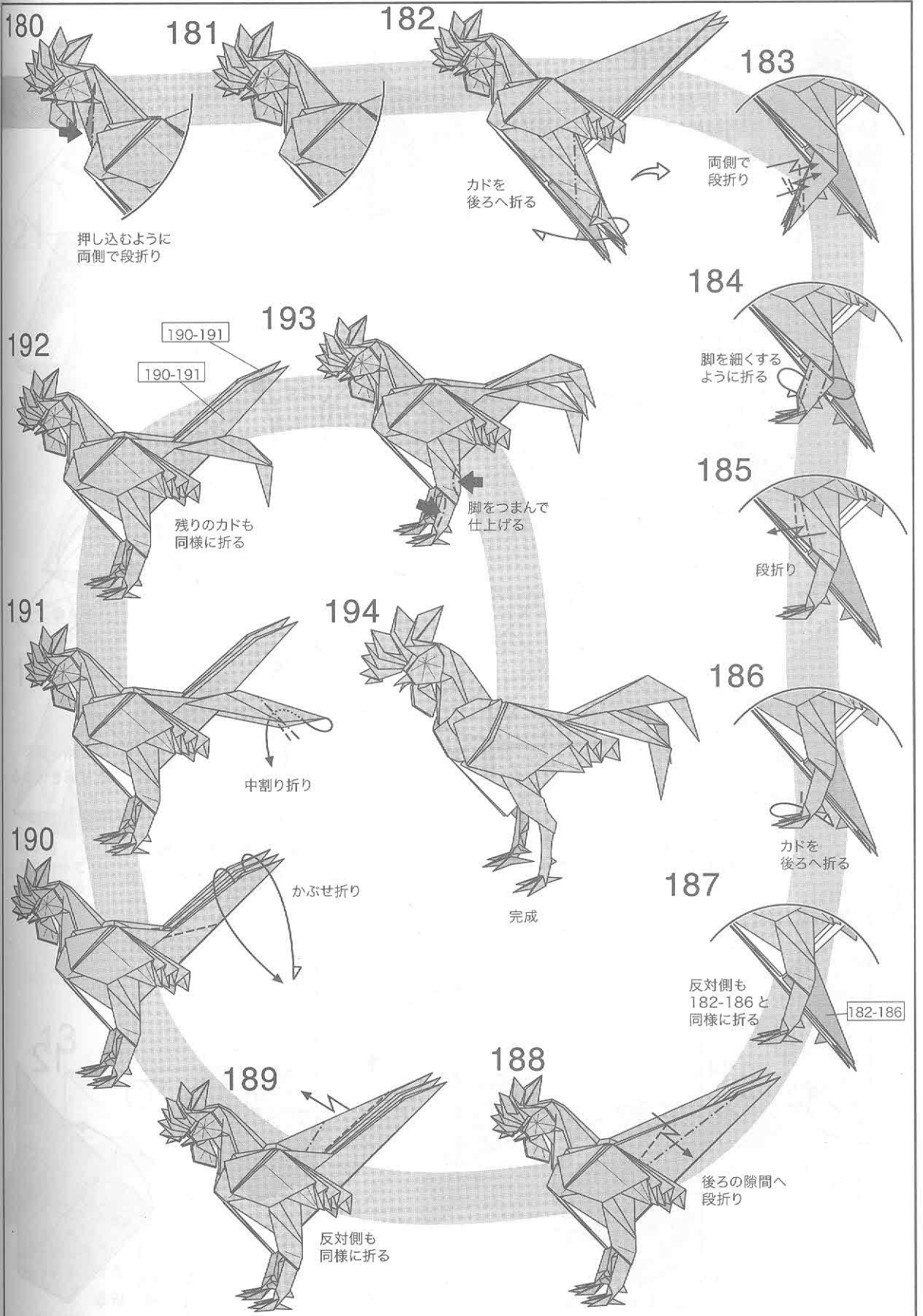

# 象 Elephant

作/図：合谷 哲哉

Model and diagram: Tetsuya Gotani

創作：2013/04/17

作図：2013/05/01

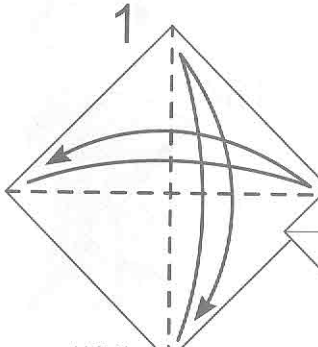
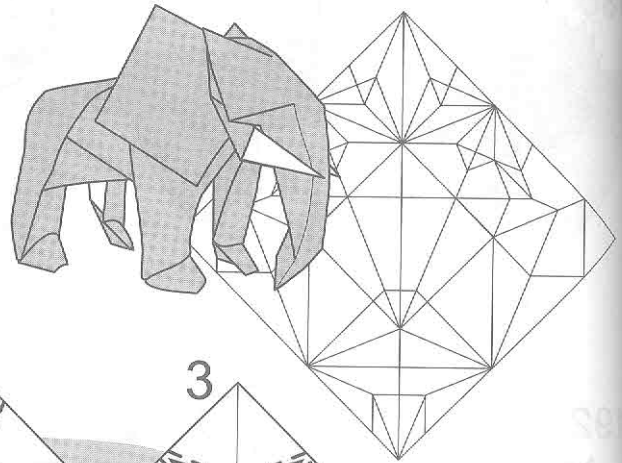

1  
対角線に  
折り筋をつける

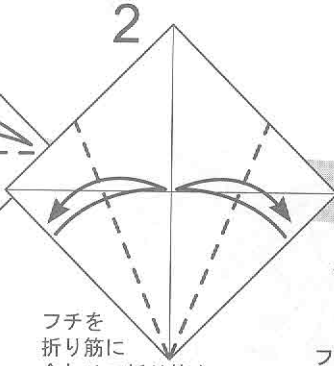

2  
フチを  
折り筋に  
合わせて折り筋を  
付ける

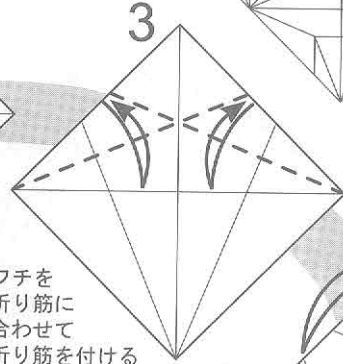

3  
フチを  
折り筋に  
合わせて  
折り筋を付ける

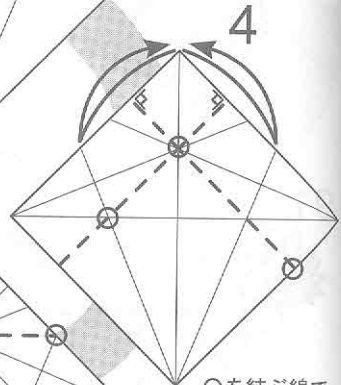

4  
○を結ぶ線で  
折り筋を付ける

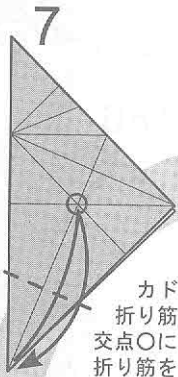

5  
カドを  
折り筋の  
交点○にあわせて  
折り筋をつける

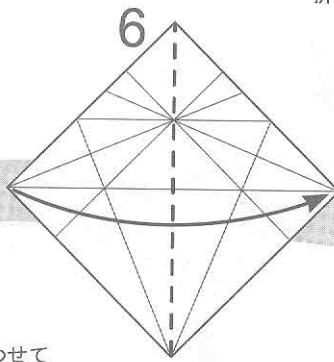

6  
半分に折る

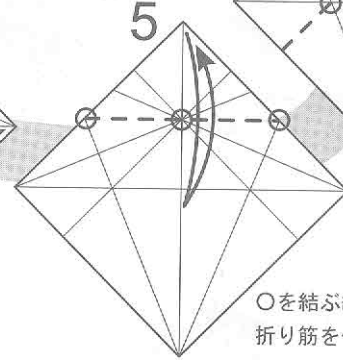

7  
○を結ぶ線で  
折り筋を付ける

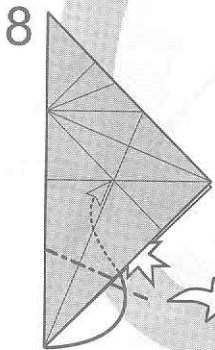

8  
ついている  
折り筋で  
中割り折り

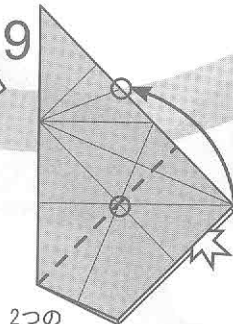

9  
2つの  
○に注意してひろげる

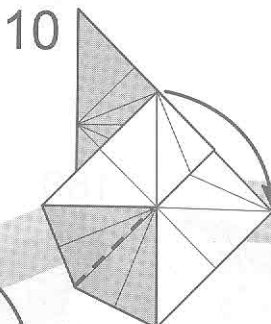

10  
一度とじる

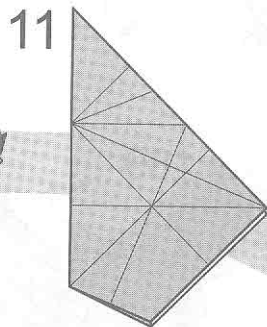

11  
反対側も  
9と同様に折る

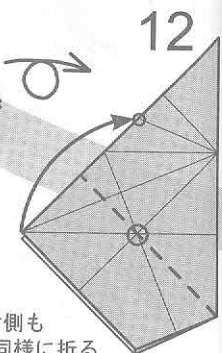

12

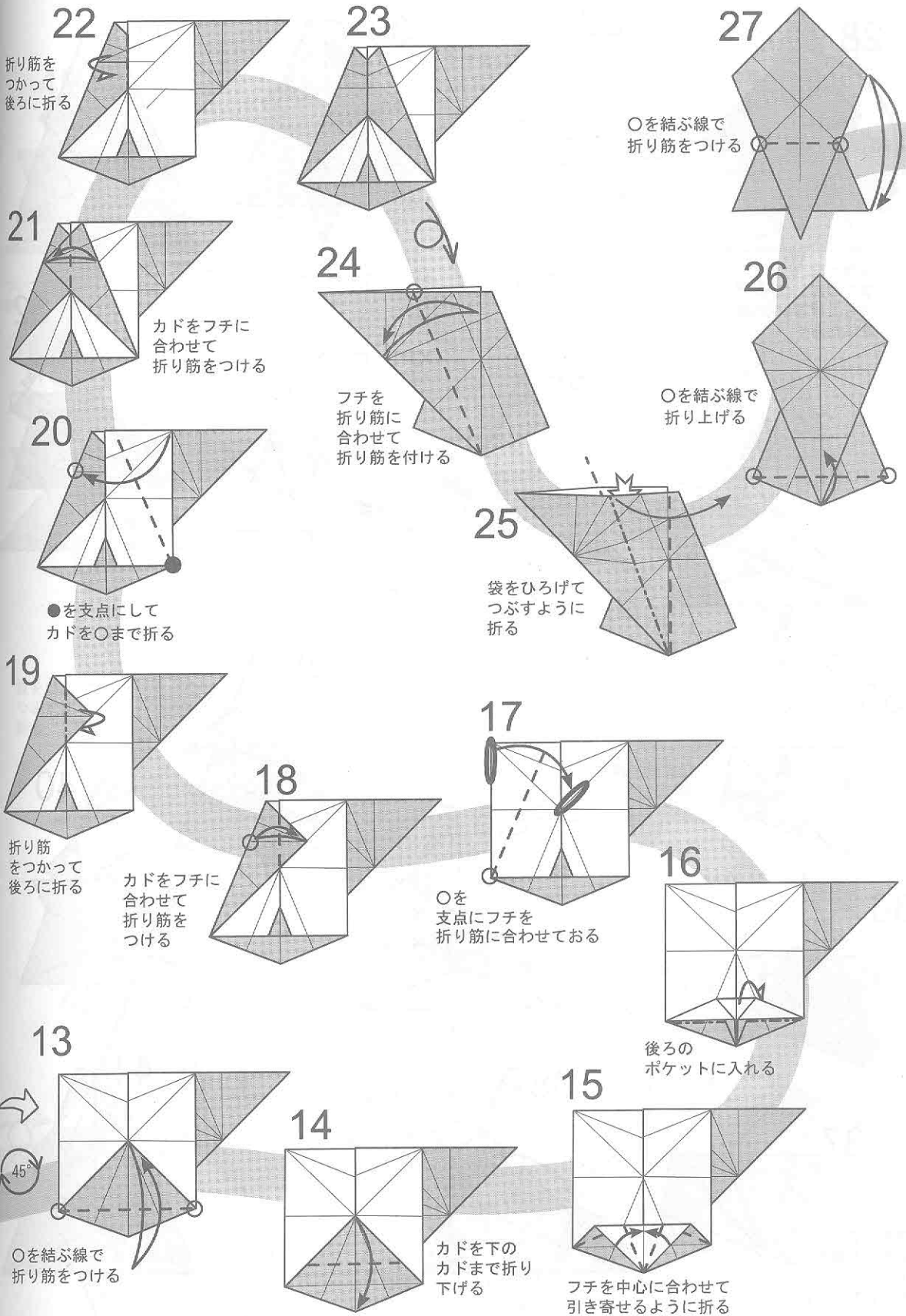

28

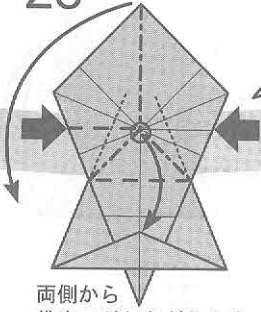

両側から袋をつぶしながら○を持ち上げるように折りに左にたおす

29

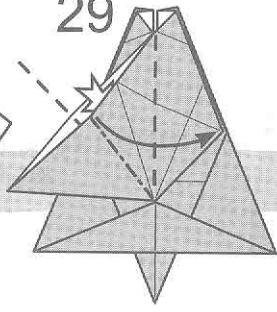

袋をひろげてつぶすように折る

30

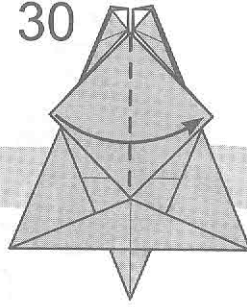

カドを一枚反対側に折る

31

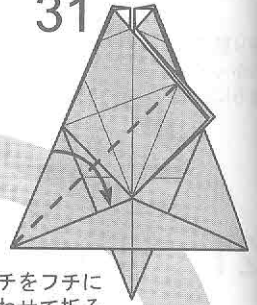

フチをフチに合わせて折る

32

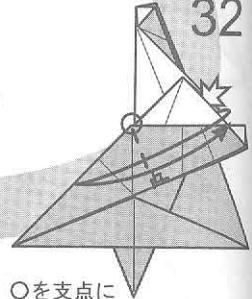

○を支点にフチに沿って折り下げ折り筋をつける

32.5 (途中図)

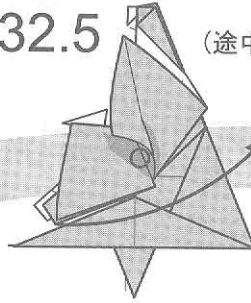

○に強く折り筋をつけてもどす

34

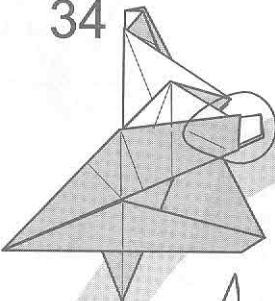

○の中を拡大

33

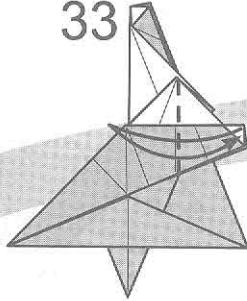

ついている折り筋をカドまで延長する

35

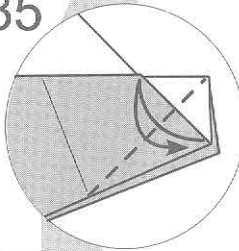

○を結ぶ線で折り筋をつける

39

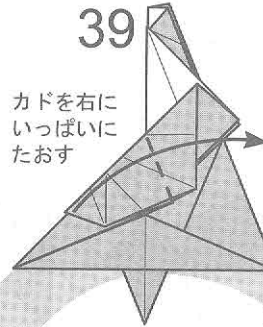

カドを右にいっぱいいたおす

38.5 (途中図)

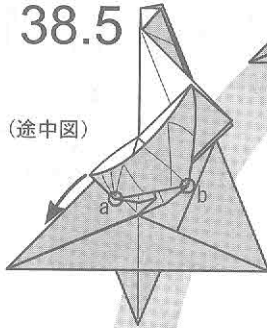

(途中図)

40

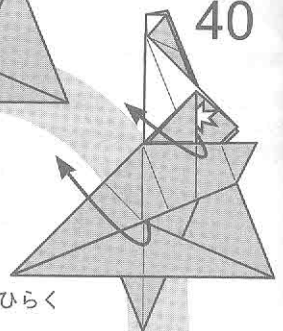

大きく左上にひらく

36

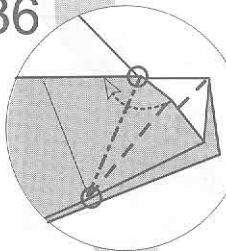

○を結ぶ線で山折りしてずらすように中割り折り

37

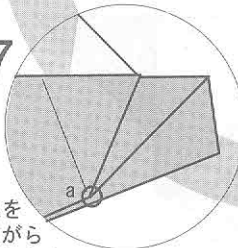

二つの袋を開きabを結ぶ線を山折りしながらカドを左にたおす

38

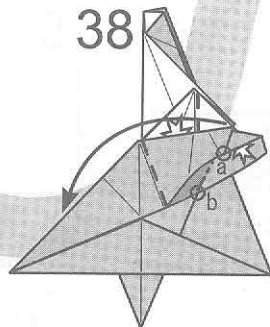

41

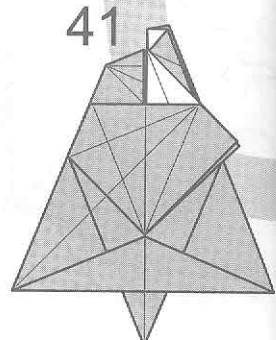

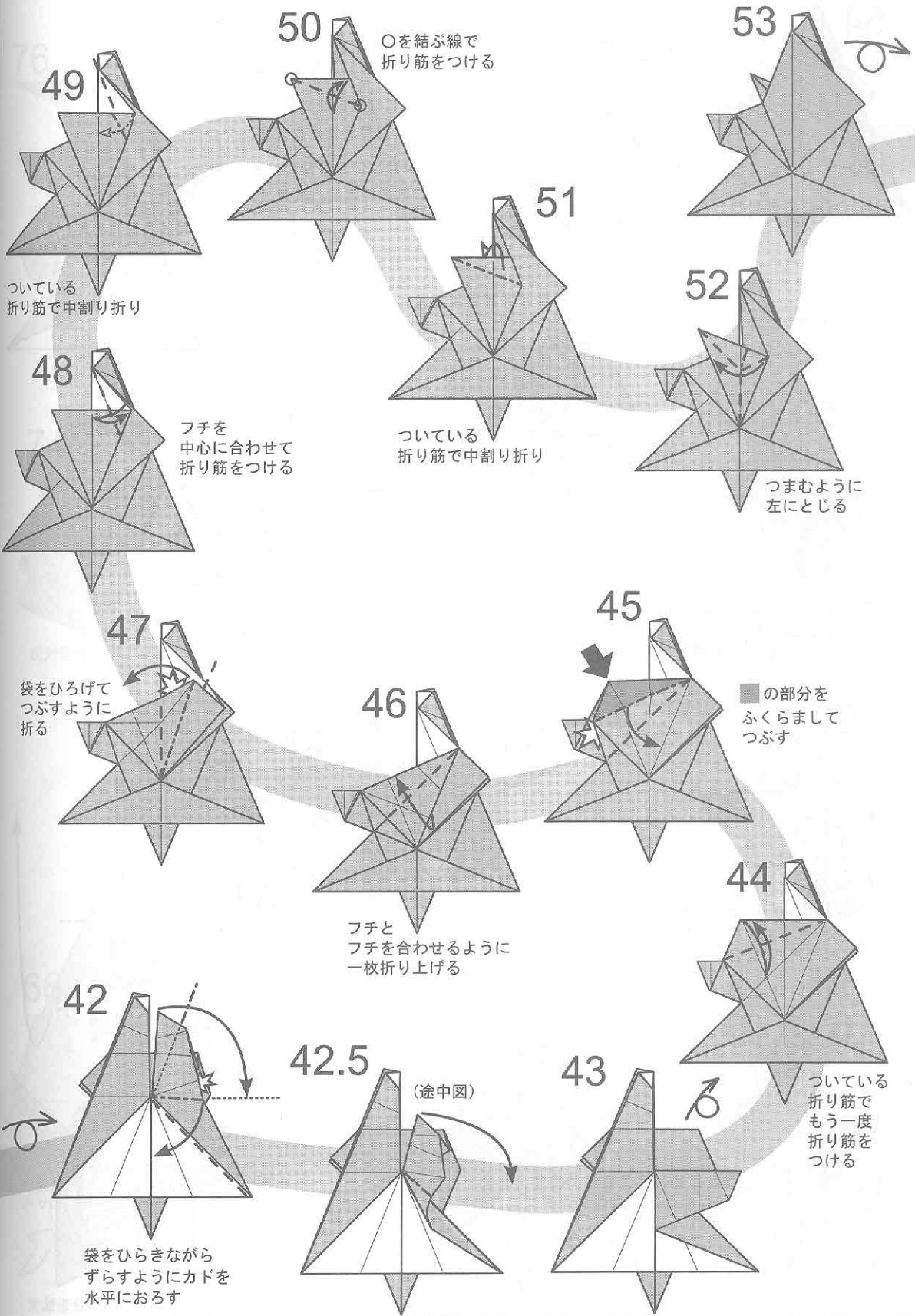

49

ついている  
折り筋で中割り折り

50

○を結ぶ線で  
折り筋をつける

53



51

ついている  
折り筋で中割り折り

52

つまむように  
左にとじる

48

フチを  
中心に合わせて  
折り筋をつける

45

■の部分  
ふくらまして  
つぶす

47

袋をひろげて  
つぶすように  
折る

46

フチと  
フチを合わせるように  
一枚折り上げる

42



袋をひらきながら  
ずらすようにカドを  
水平におろす

42.5

(途中図)

43



ついている  
折り筋で  
もう一度  
折り筋を  
つける

44

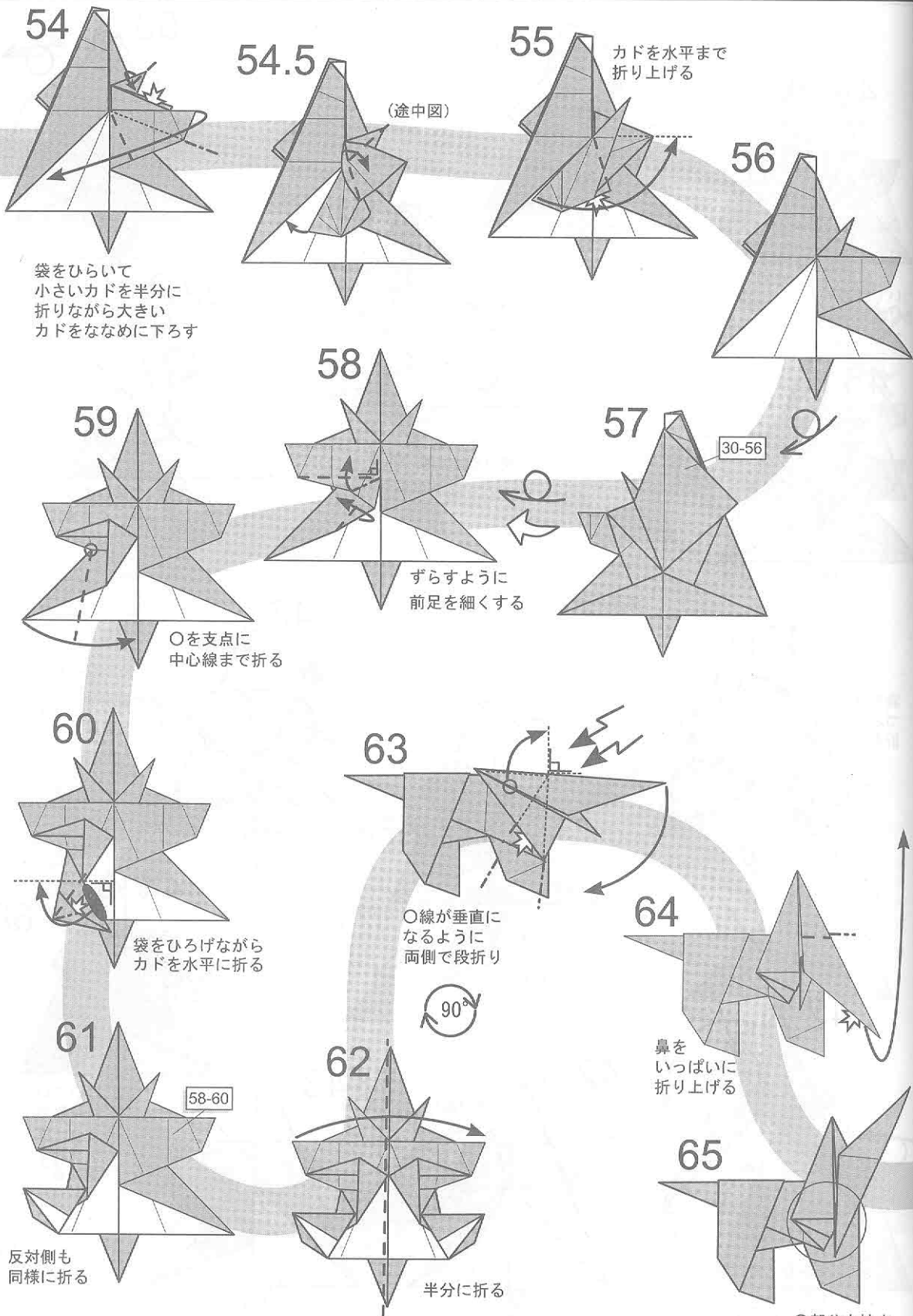

袋をひらいて  
小さいカドを半分  
折りながら大きい  
カドをななめに下ろす

カドを水平まで  
折り上げる

(途中図)

○を支点に  
中心線まで折る

ずらすように  
前足を細くする

30-56

○線が垂直に  
なるように  
両側で段折り

袋をひろげながら  
カドを水平に折る

90°

鼻を  
いっぱい  
折り上げる

反対側も  
同様に折る

半分に折る

○部分を拡大

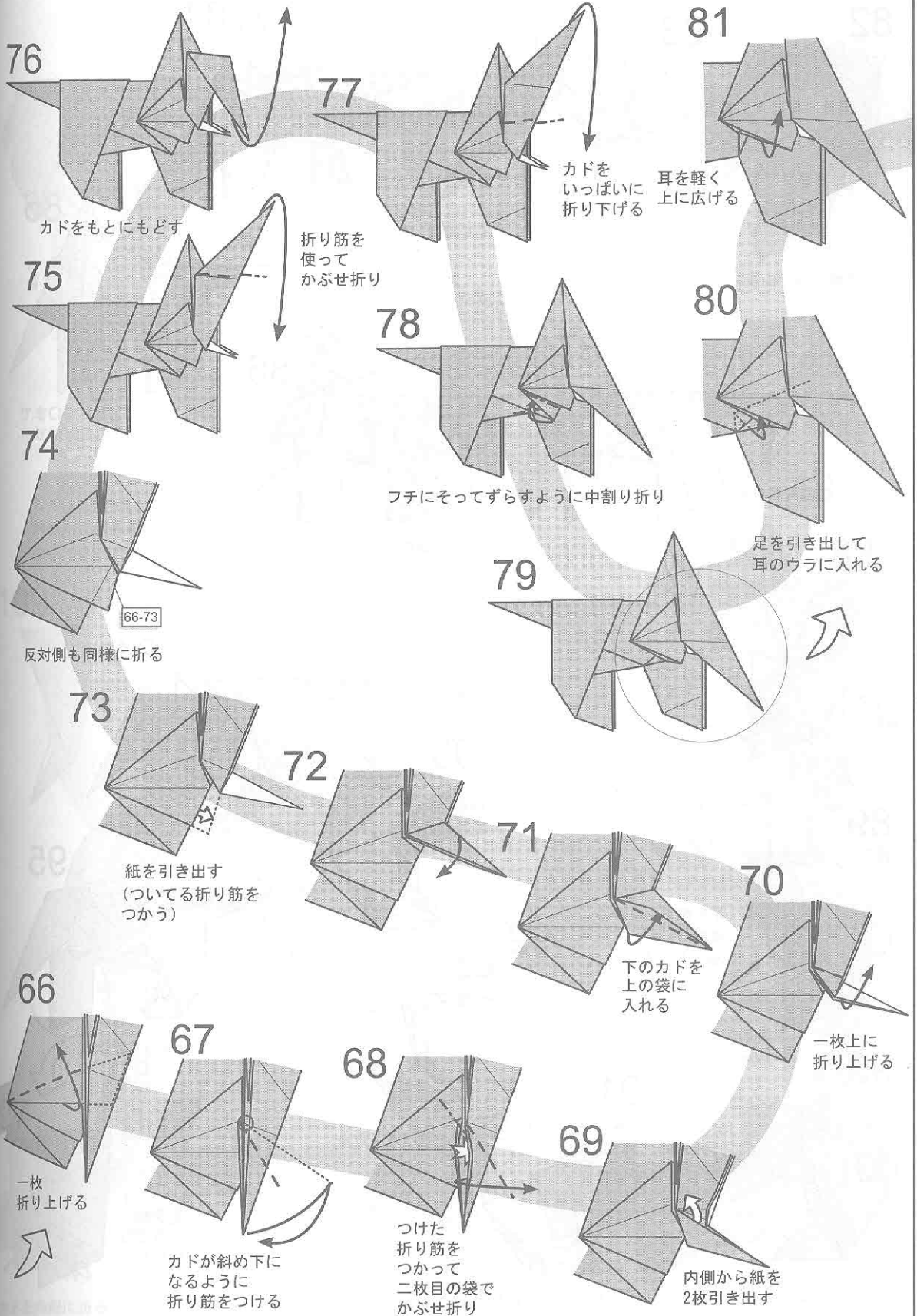



82

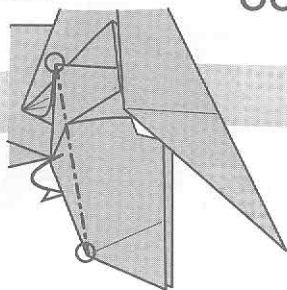

○を結ぶ線で山折り

83

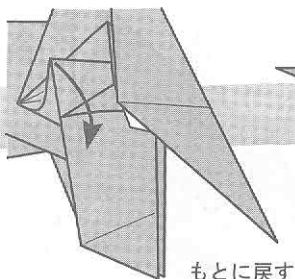

もとに戻す

84

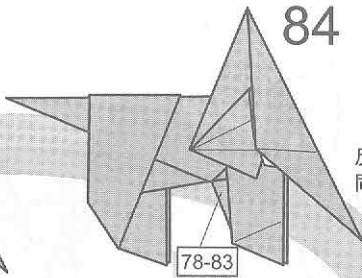

反対側も  
同様に折る

85

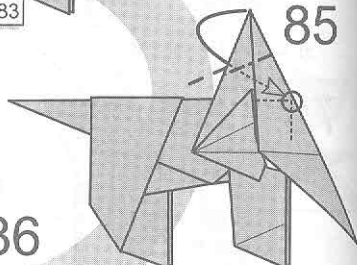

カドを○まで  
中割り折り

87

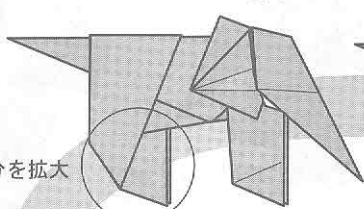

○部分を拡大

86

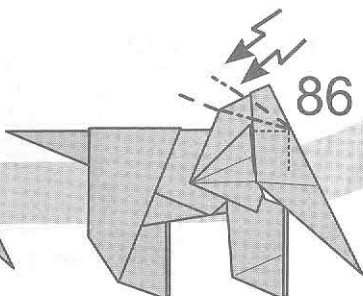

両側で段折り

88

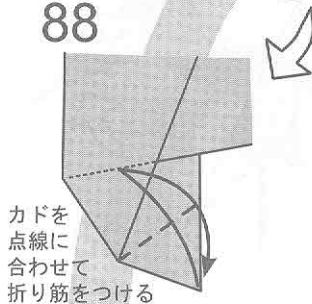

カドを  
点線に  
合わせて  
折り筋をつける

94

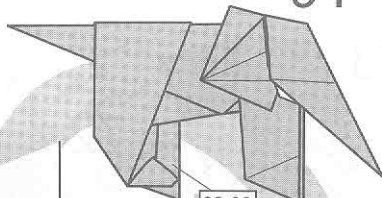

88-93

93

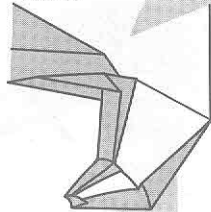

89

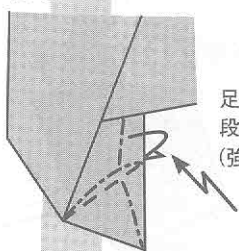

足を細くしながら  
段折り  
(強く折らない)

92

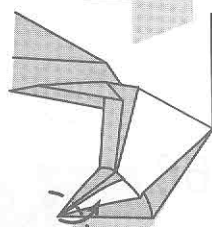

カドを内側に折る

95

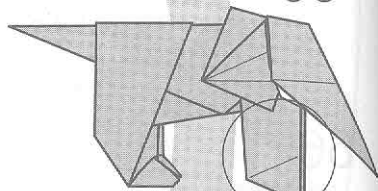

前足を拡大

90

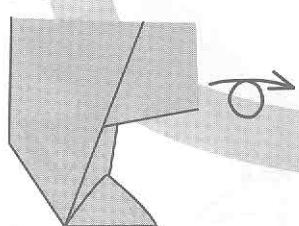

91

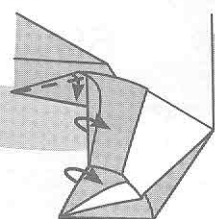

(強く折らない)

96

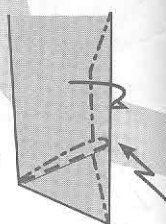

足を細く  
しながら  
段折り

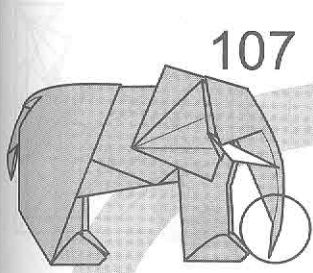

107

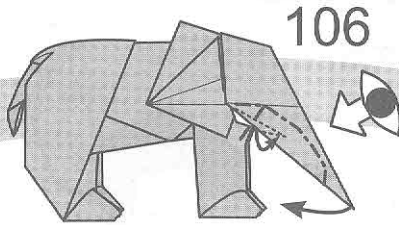

106

鼻を細くしながらキバを出す

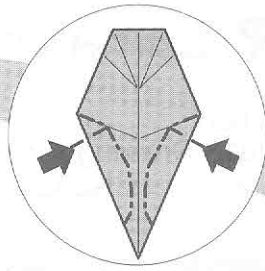

105

鼻を拡大

108

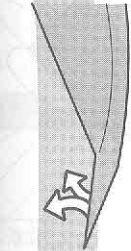

しっぽと同様に  
内側から紙を引き出し  
袋状に広げる

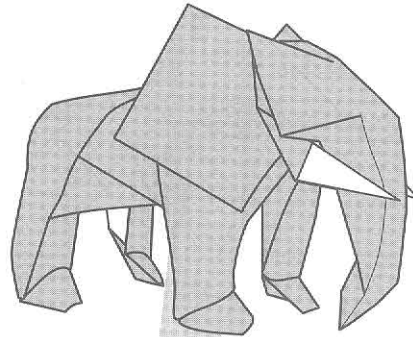

できあがり

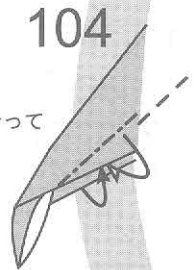

両側を  
内側に折って  
しっぽを  
細くする

104

109

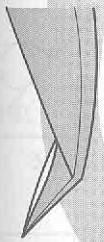

耳の間は  
たいらにする

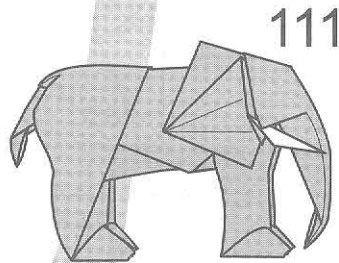

111

内側から  
紙を引き出し  
袋状に広げる

103



しっぽを拡大

102

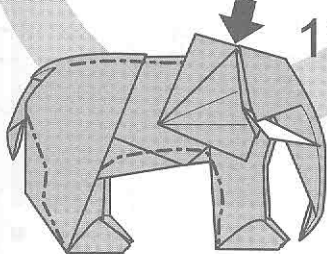

体に丸みをつけて仕上げる

110

101

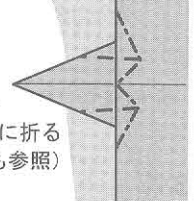

しっぽを  
図のように折る  
(次の図も参照)

98

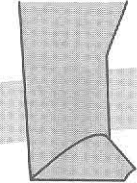

97

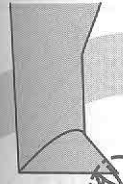

カドを内側に折る

99

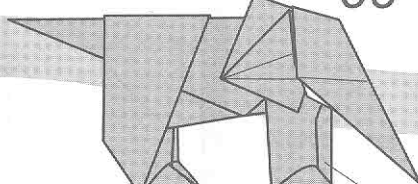

反対側も同様に折る

96-98

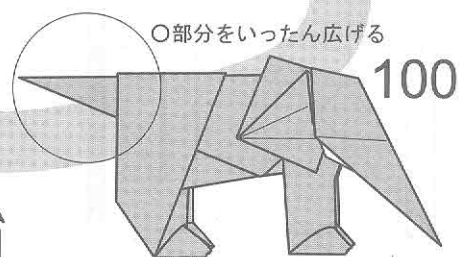

○部分をいったん広げる

100

# リヤマ Lama 川畑文昭

2012 Creation  
April 30, 2013 Drawing  
Fumiaki Kawahata

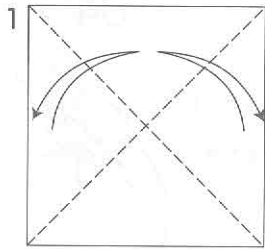
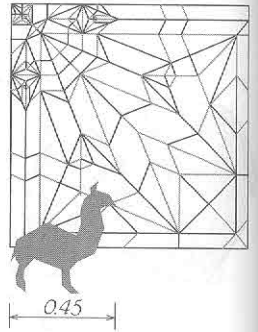
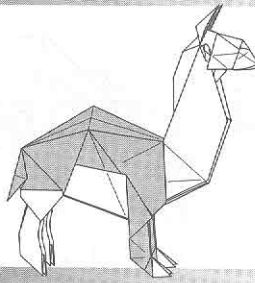

折すじをつける

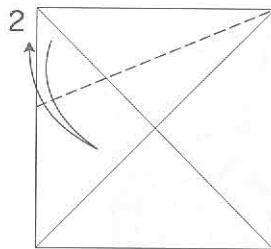

折すじをつける

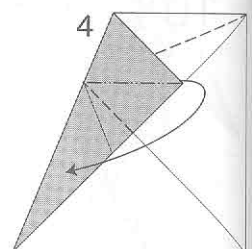
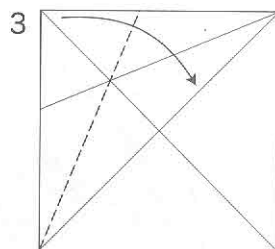

カドをつまむように折る

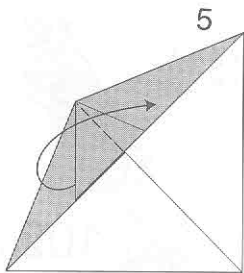

カドを折りかえす

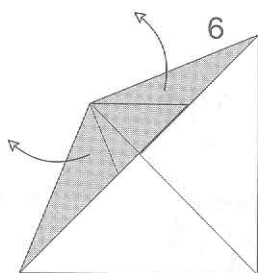

広げて戻す

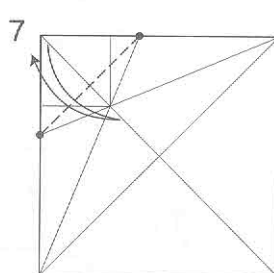

折すじをつける

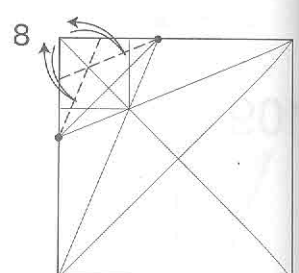

折すじをつける

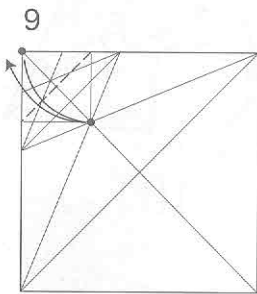

折すじをつける

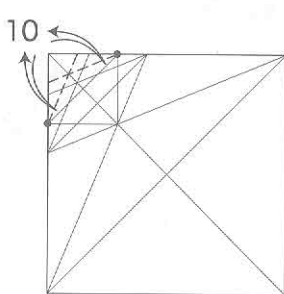

折すじをつける

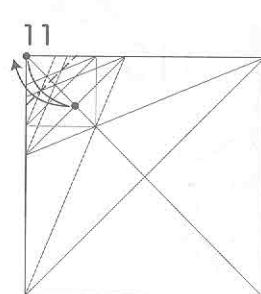

折すじをつける

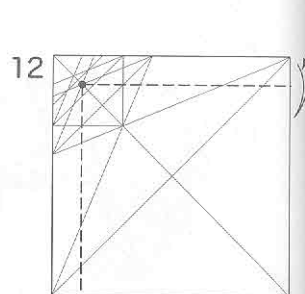

折すじをつける

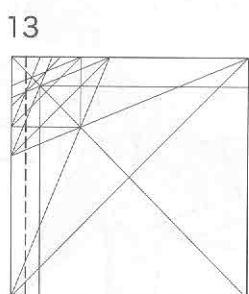

半分の幅で折すじをつける

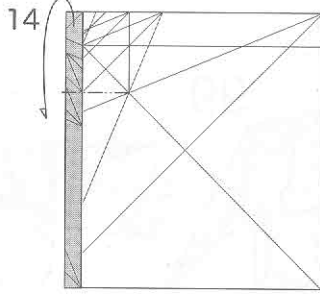

向こう側に折り返す  
折るのは図の山線範囲

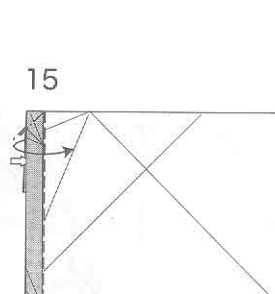

広げてつぶす

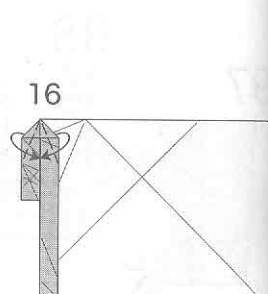

半分の角度で折る

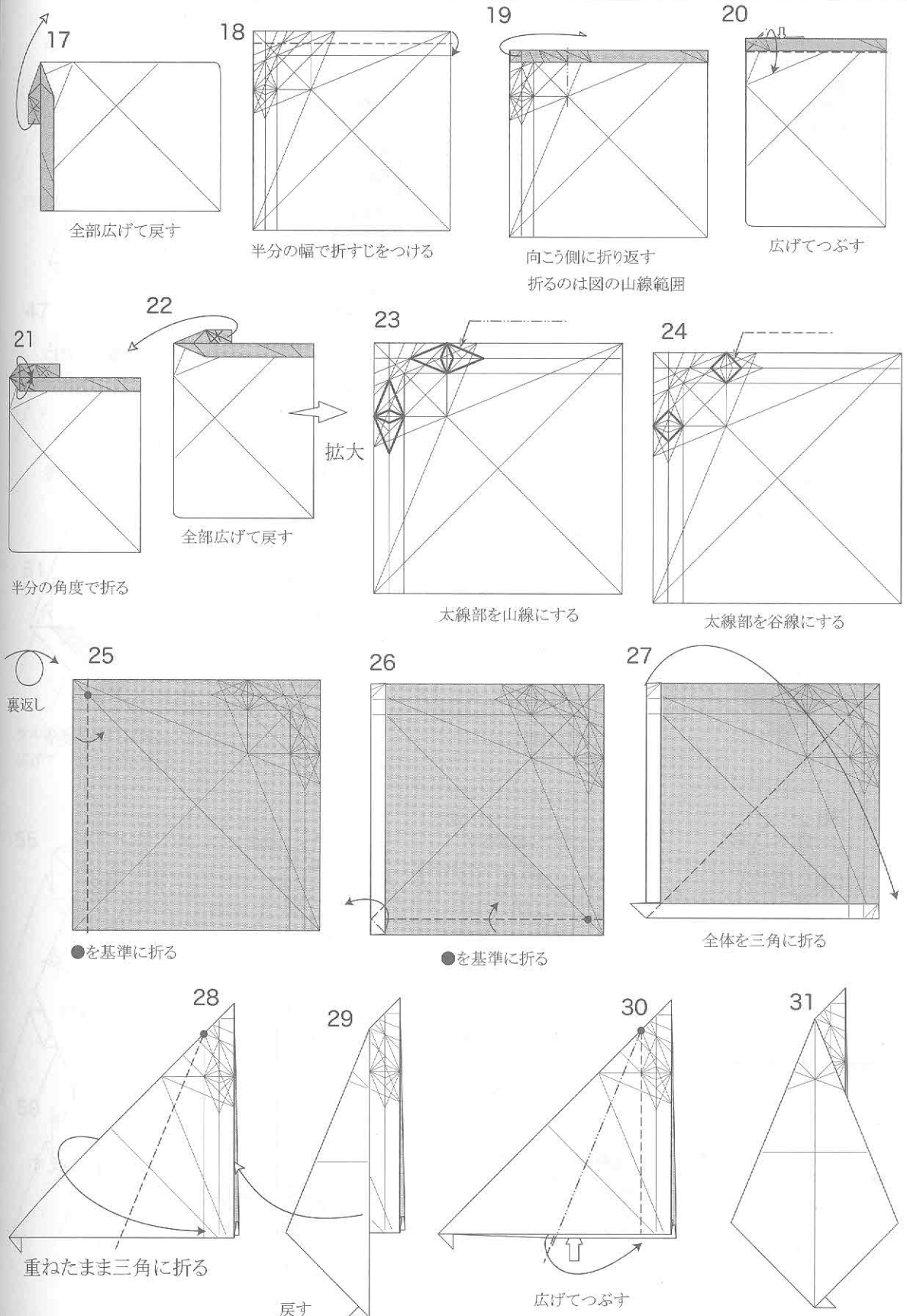

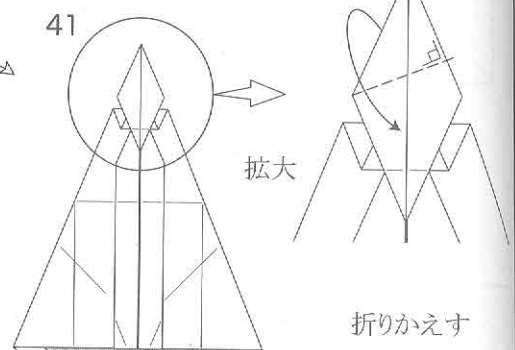
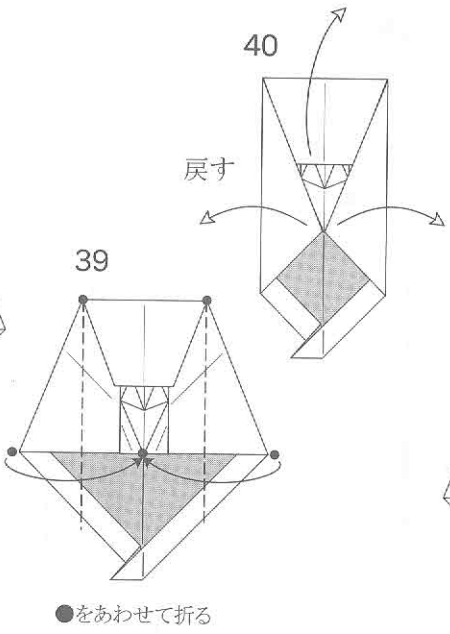
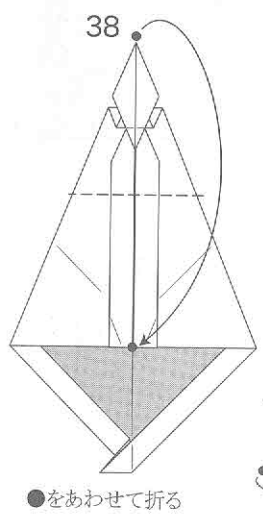
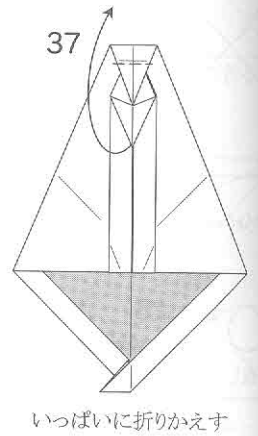
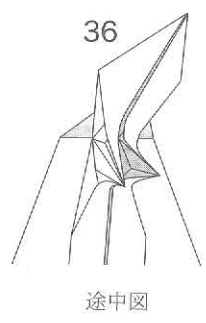
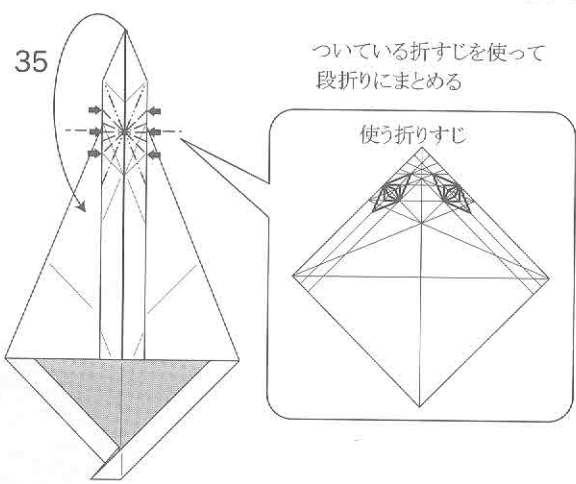
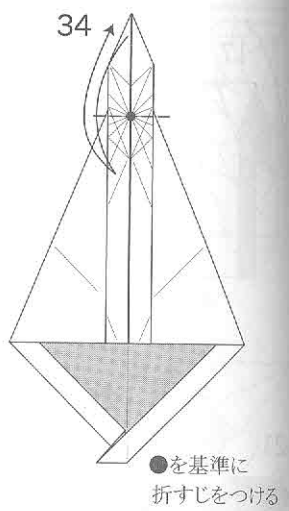
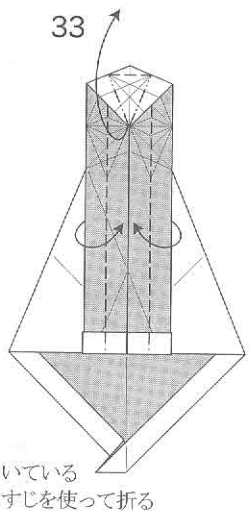
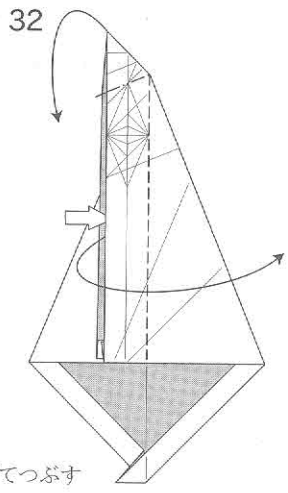
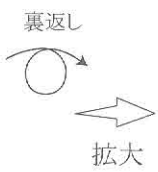

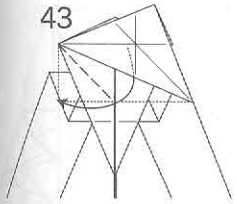

43 内側から1枚引き出す

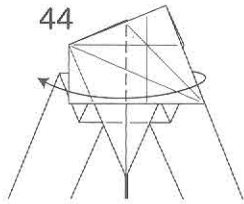

44 折りかえす

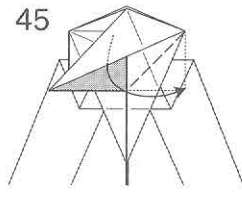

45 内側から1枚引き出す

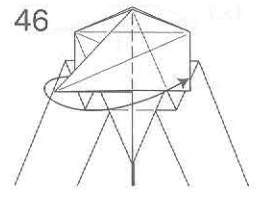

46 折りかえす

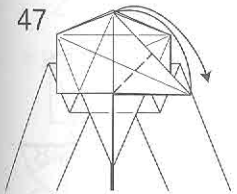

47 折すじをつける

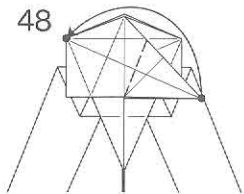

48 ●をあわせて  
折すじをつける

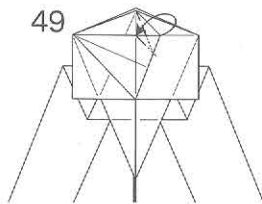

49 中わり折り

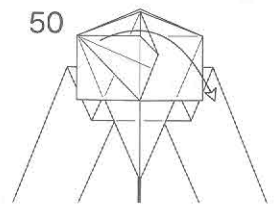

50 戻す

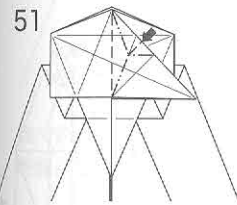

51 ツルの基本形のように  
広げてつぶすように折る

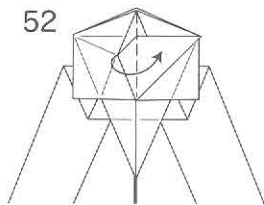

52 折りかえす

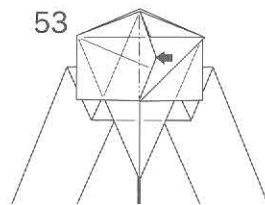

53 内側に沈めこむ

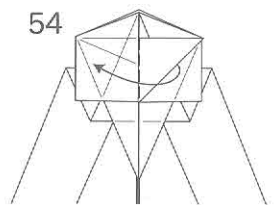

54 折りかえす

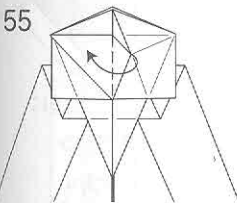

55 折りかえす

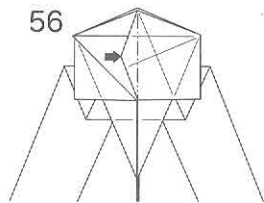

56 内側に沈めこむ

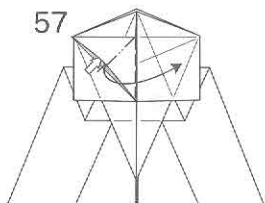

57 広げてつぶす

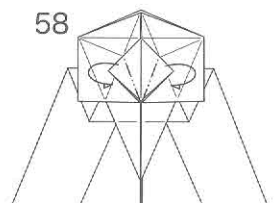

58 重ねて向こう側に折り込む  
(中わり折りでは無いので注意)

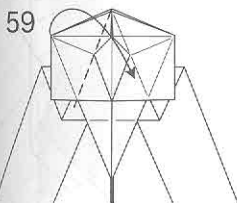

59 折りかえす

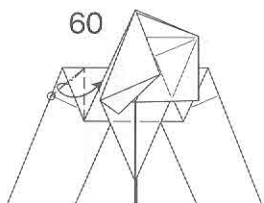

60 引き寄せるように折る

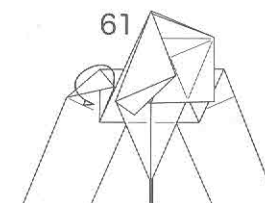

61 内側に折りかえす

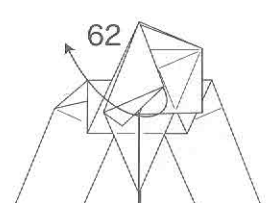

62 戻す

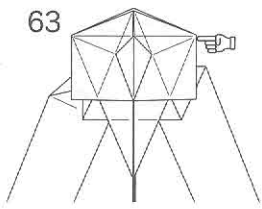

63 右側も 59 ~ 62 までと同じように折る

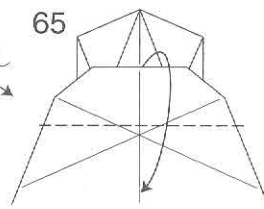
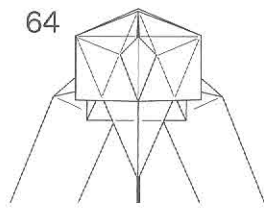

65 いっぱいに折る

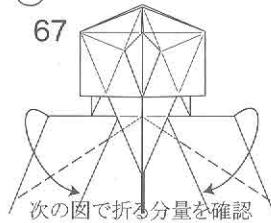
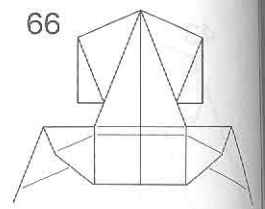

67 次の図で折る分量を確認

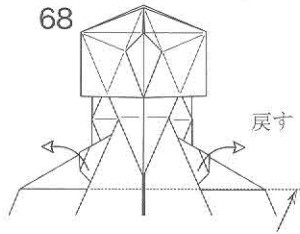

戻す

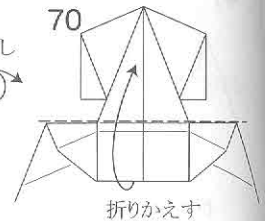
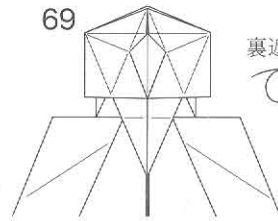

70 折りかえす

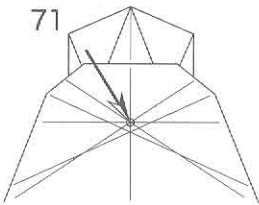

71 ○点が 81 で折る基準になる

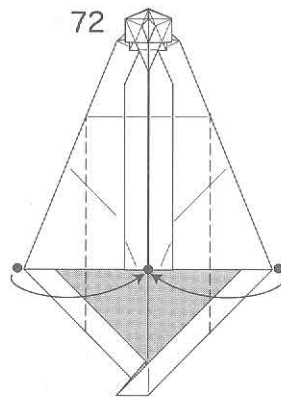

72 ●をあわせて折る

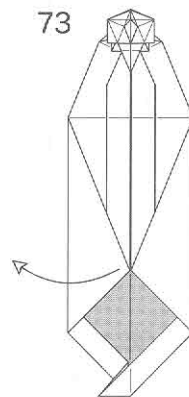

73 1枚戻す

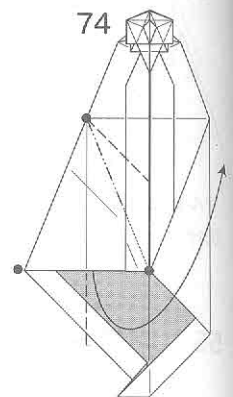

74 段に折るように引き寄せる

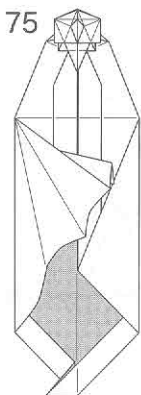

75 途中図

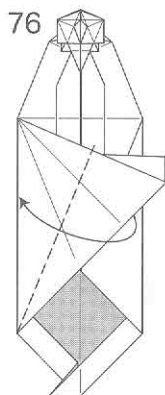

76 半分の角度で折る

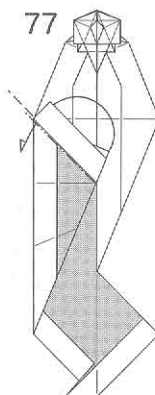

77 中わり折り

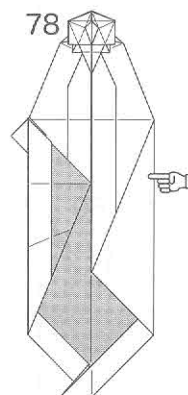

78 右側も 73 ~ 77 までと同じように折る

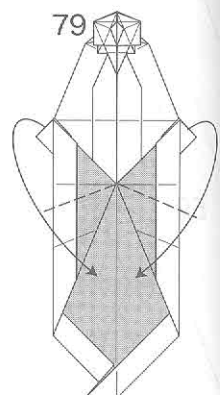

79 折りかえす

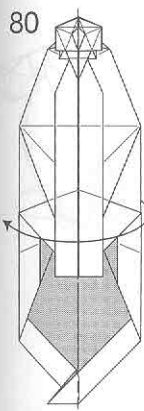

半分に折る

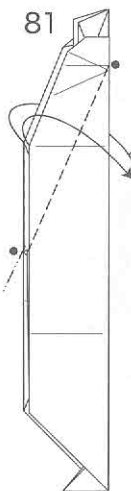

●を結ぶ線にかぶせ折り

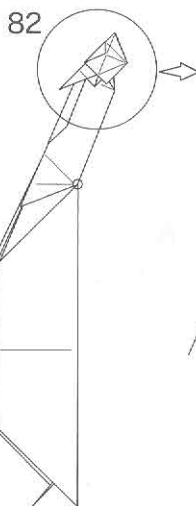

拡大

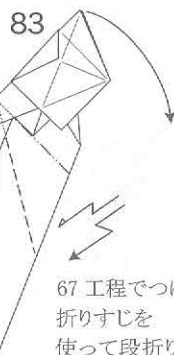

67工程でつけた折すじを使って段折り  
向こう側も同時に折る

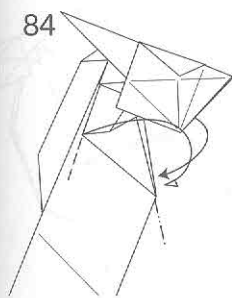

段で折った部分を内側に折り返す

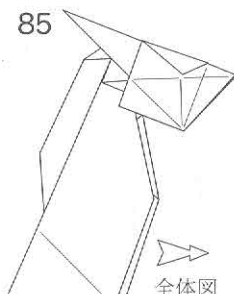

全体図

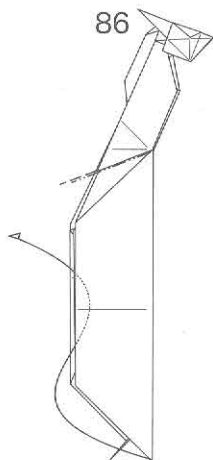

中わり折り

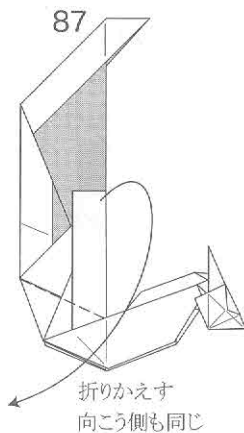

折りかえす  
向こう側も同じ

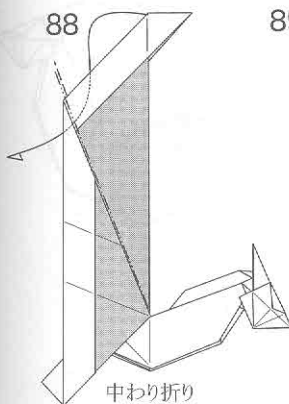

中わり折り

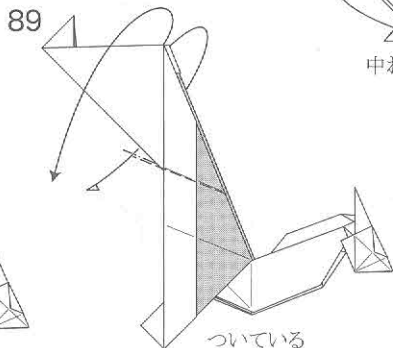

ついている折すじでかぶせ折り

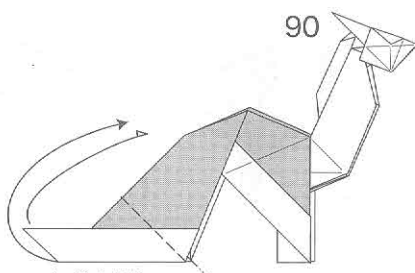

かぶせ折り

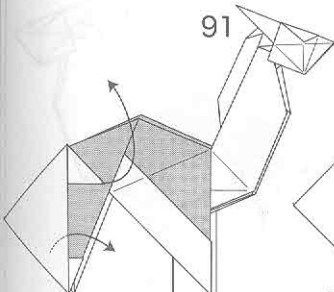

内側の重なりを外に引き出す  
向こう側も同じ

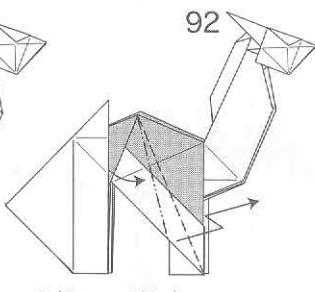

段折りして引き寄せるように折る  
向こう側も同じ

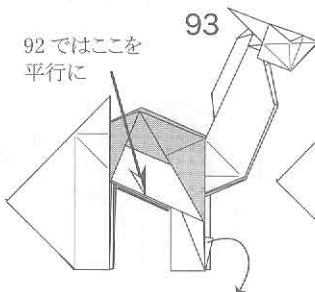

92ではここを平行に

内側の重なりを外に引き出す  
向こう側も同じ

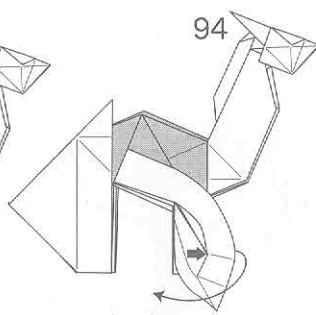

凸部を押し込みひっくり返す  
向こう側も同じ



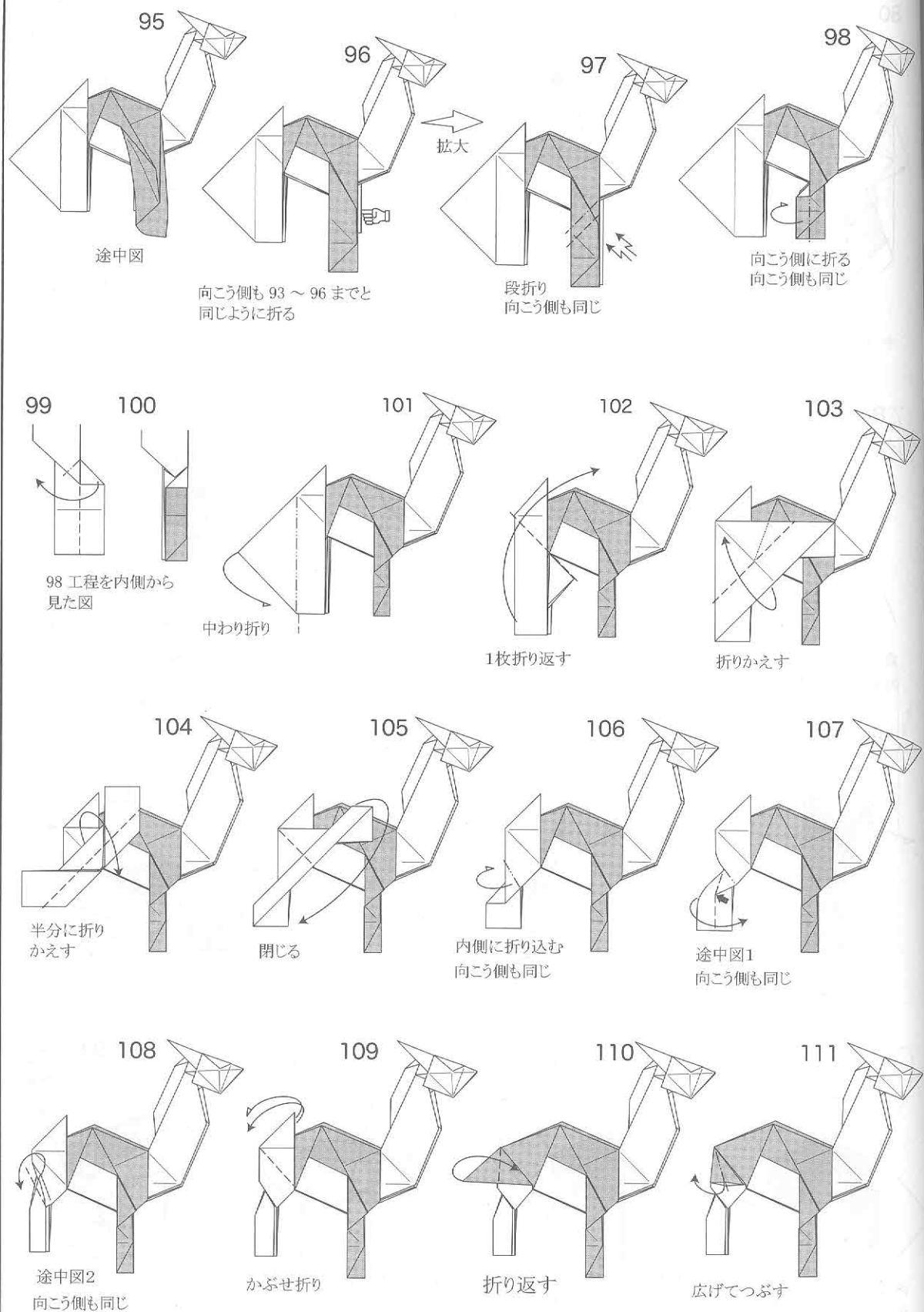

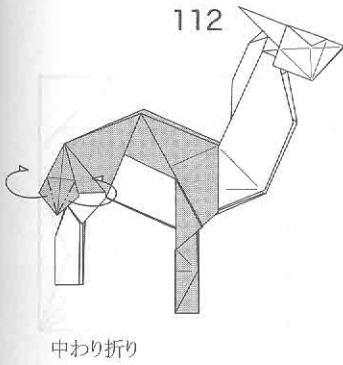

中わり折り

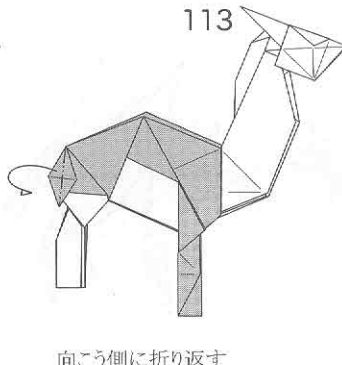

向こう側に折り返す

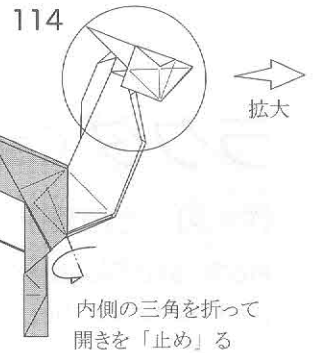

内側の三角を折って開きを「止め」る

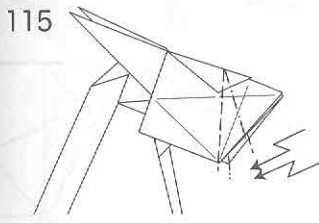

段折り

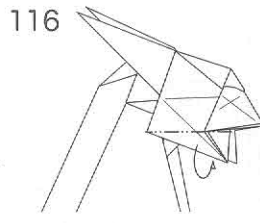

内側に折り込む  
向こう側も同じ

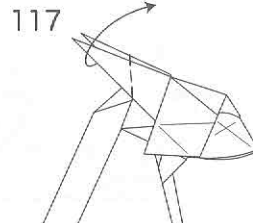

耳を起こす  
向こう側も同じ

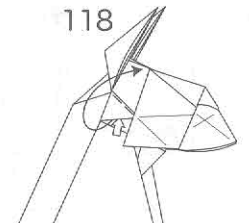

目を起こす  
向こう側も同じ

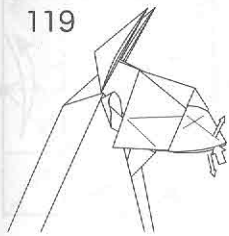

口を広げる

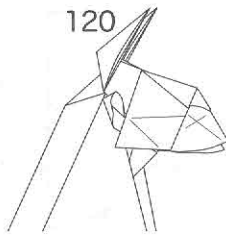

顔の完成

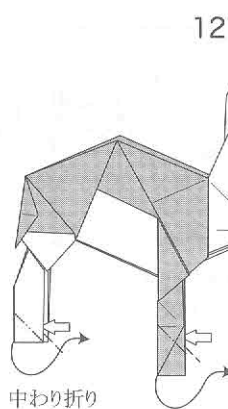

中わり折り  
向こう側も同じ

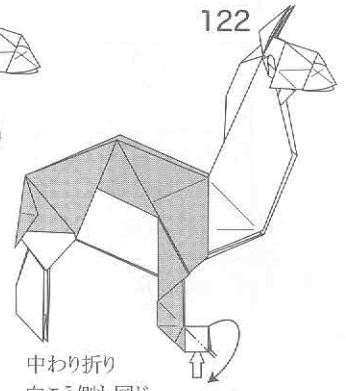

中わり折り  
向こう側も同じ

お腹から指をいれ  
背中を風船のように  
立体的に広げる

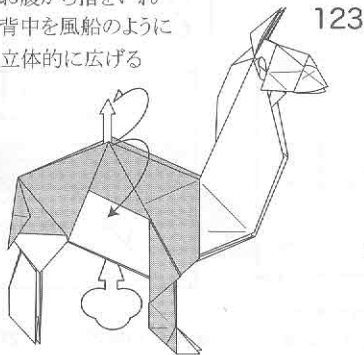

123

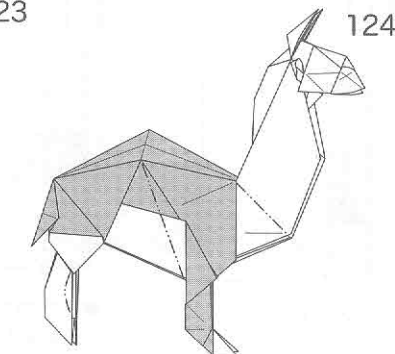

124

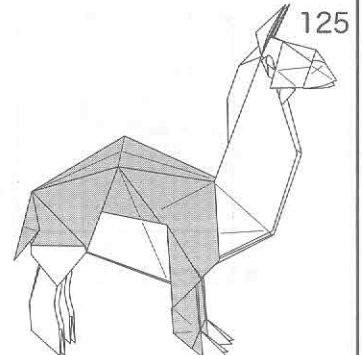

125

立体的な折すじをつける

できあがり

# ラクダ Camel

作・図 土田耕平

Model and Diagram

by Tsuchida Kohei

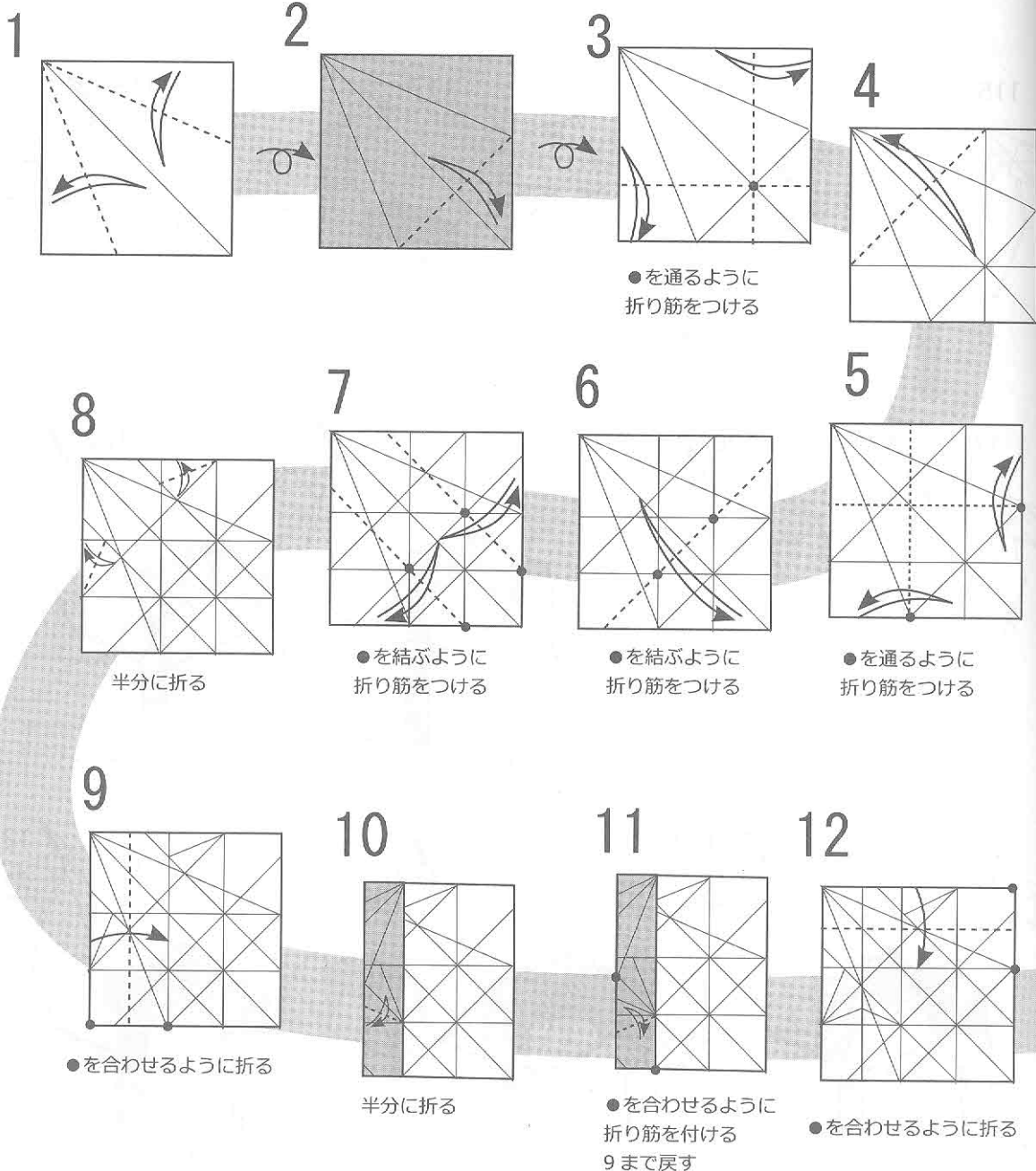
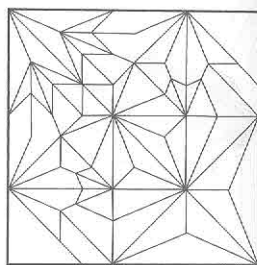
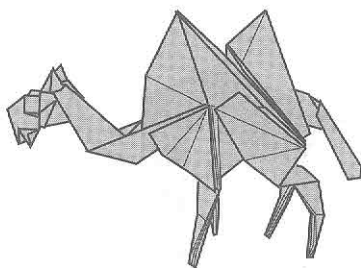

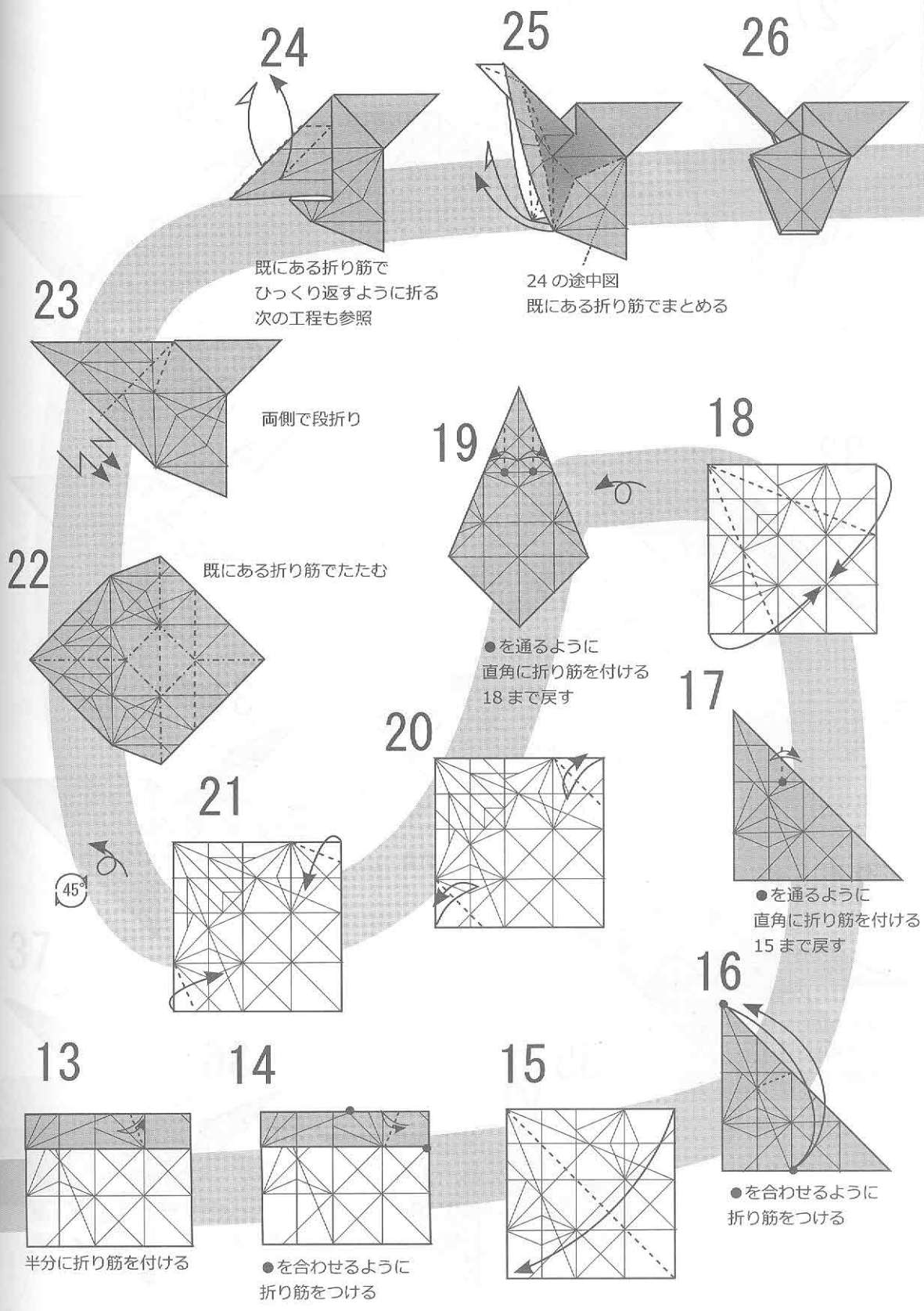

24

25

26

23

既にある折り筋で  
ひっくり返すように折る  
次の工程も参照

24の途中図  
既にある折り筋でまとめる

両側で段折り

19

18

22

既にある折り筋でたたむ

●を通るように  
直角に折り筋を付ける  
18まで戻す

17

20

●を通るように  
直角に折り筋を付ける  
15まで戻す

21

45°

16

13

14

15

半分に折り筋を付ける

●を合わせるように  
折り筋をつける

●を合わせるように  
折り筋をつける

27

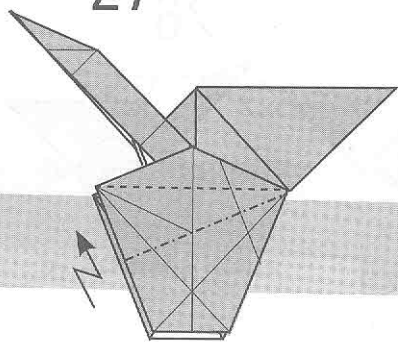

ずらすように折る  
反対側も同様

28

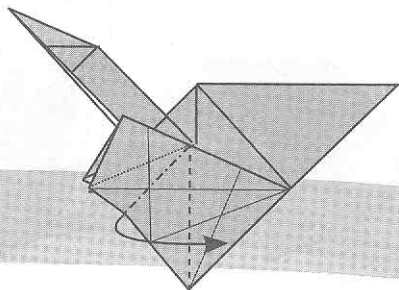

開いてつぶす  
反対側も同様

29

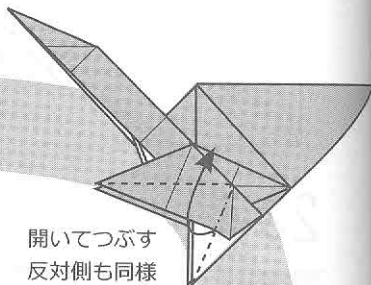

開いてつぶす  
反対側も同様

30

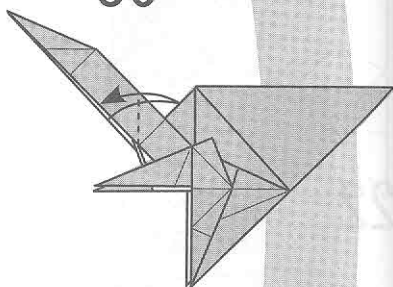

33

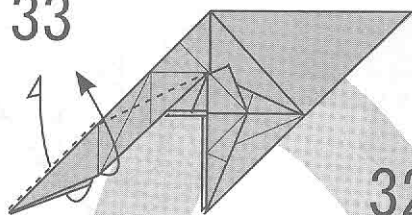

かぶせ折り

32

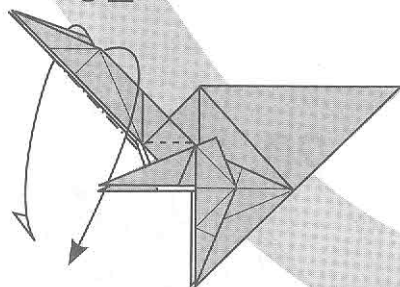

ひっくり返すように折る

31

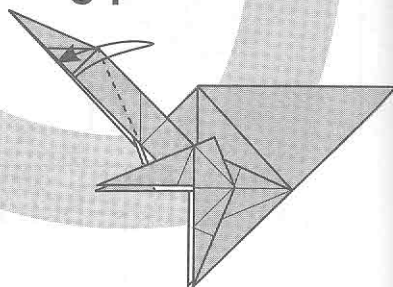

34

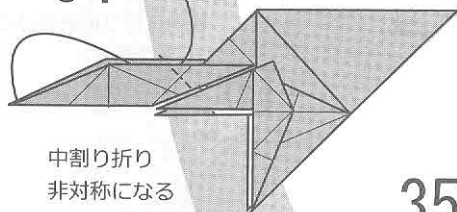

中割り折り  
非対称になる  
分厚いので注意

35

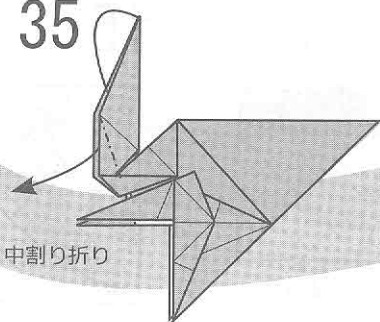

中割り折り

36

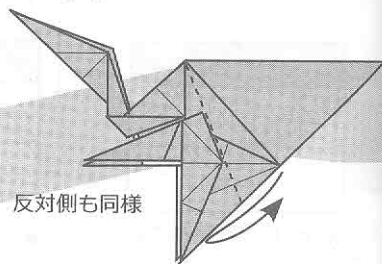

反対側も同様

45

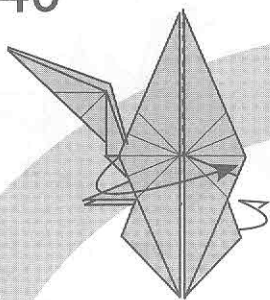

一枚めくる

46

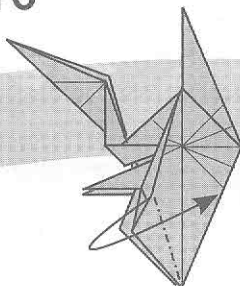

開いてつぶす  
反対側も同様

47

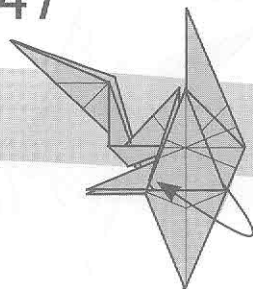

一枚めくる  
反対側も同様

44

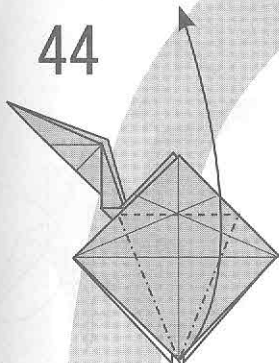

開いてつぶす

41

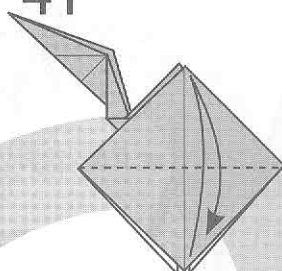

手前の一枚のみ折り筋をつける

42

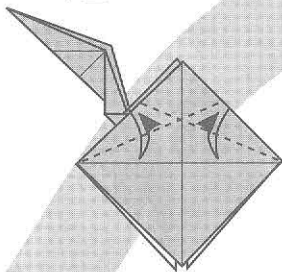

手前の一枚のみ折り筋をつける

43

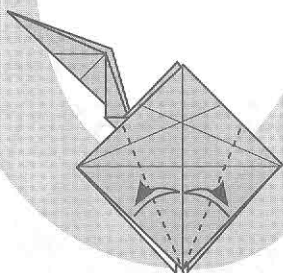

40

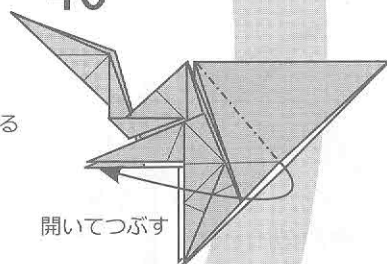

開いてつぶす

37

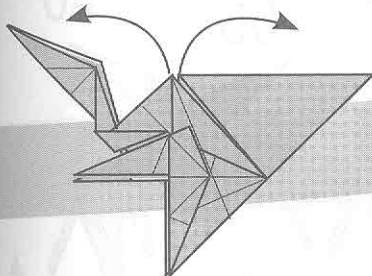

開けるところまでピンと開く  
次の工程は三角錐を合わせた  
ように立体的になる

38

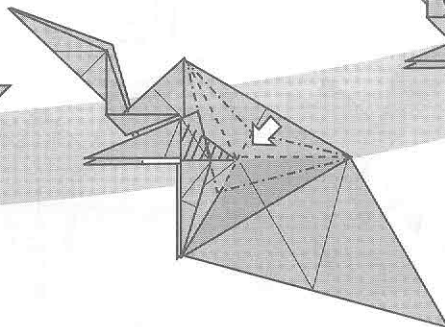

36の折り筋で沈め折り  
斜線部は閉じたまま  
反対側も同様

39

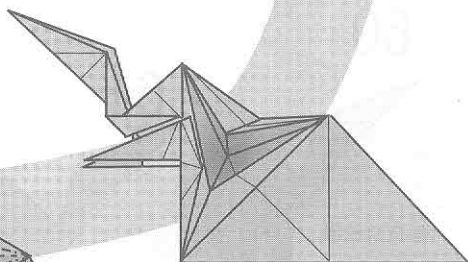

37の途中図

48

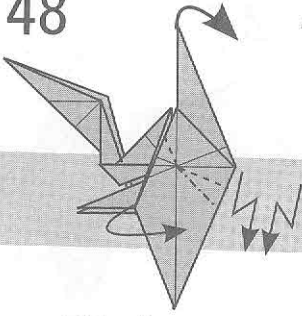

両側でずらすようにたたむ

49

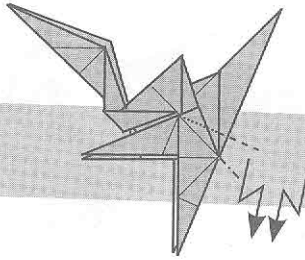

ずらすように折る

50

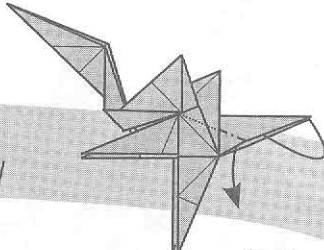

中割り折り

51

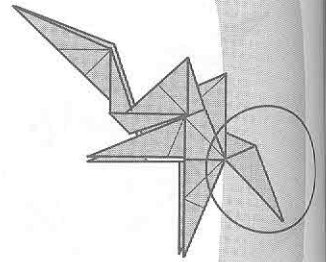

57

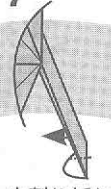

中割り折り

56



すきまに差し込む

52

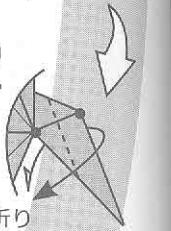

かぶせ折り

●を合わせるように折る

58

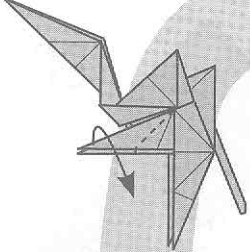

内側に折り込む

55

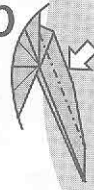

手前のみ沈め折り  
(closed sink)

54



戻す

53

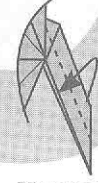

開いてつぶす

60

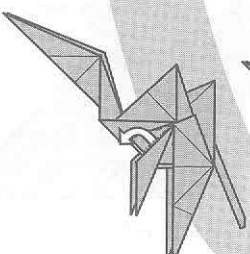

ずらすように引き出す  
反対側も同様

61

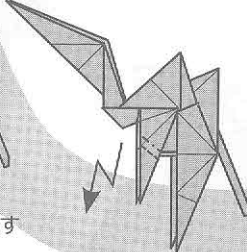

段折り  
反対側も同様

62

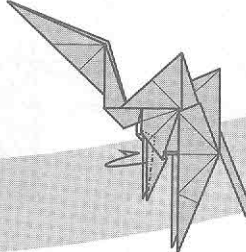

細くするように折る  
反対側も同様

63

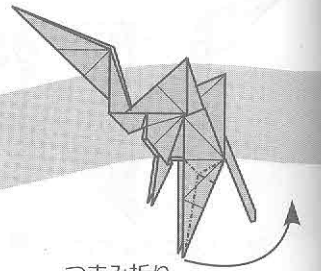

つまみ折り  
反対側も同様

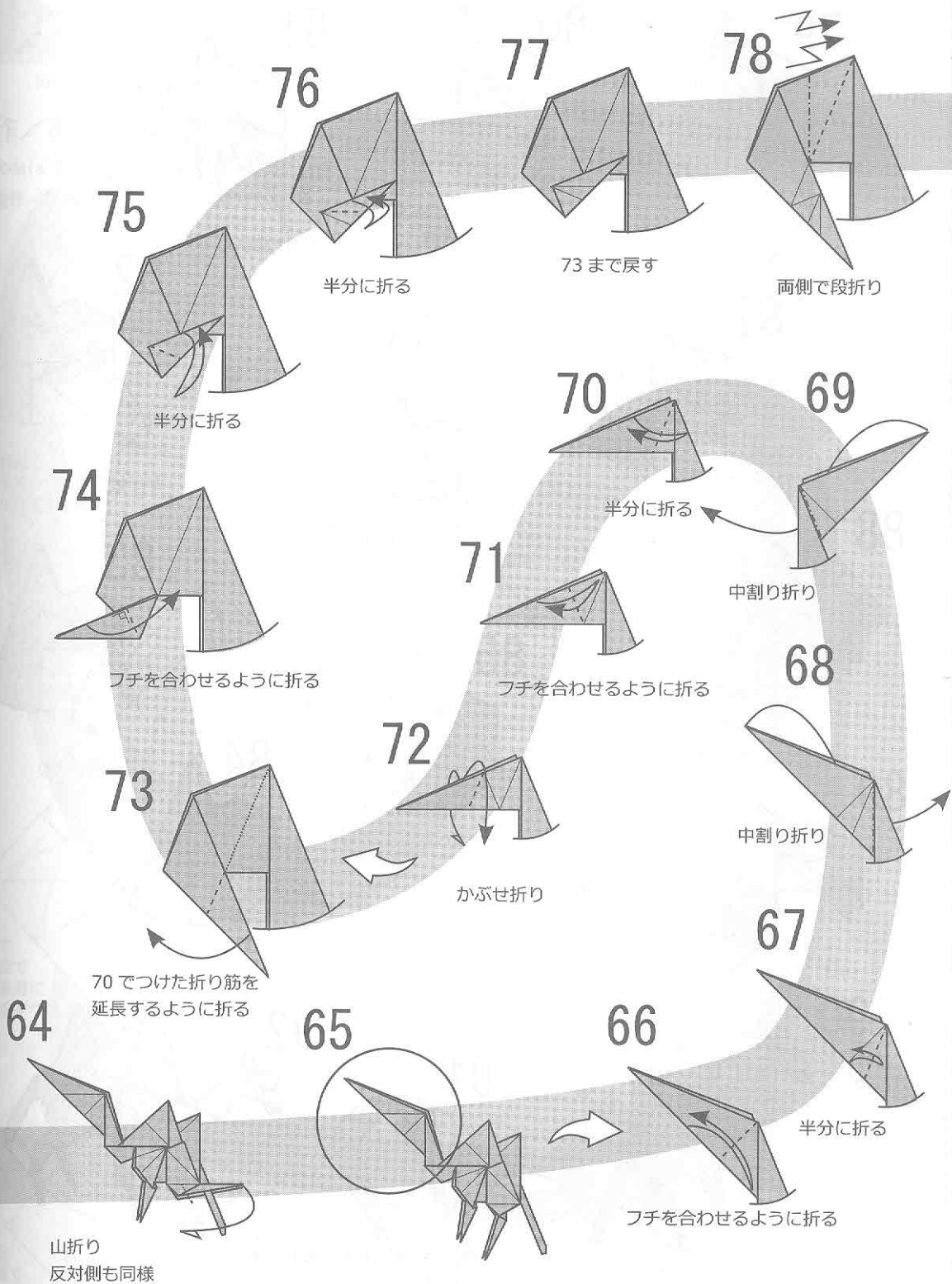

64

70 でつけた折り筋を  
延長するように折る

山折り  
反対側も同様

65

66

フチを合わせるように折る

67

半分に折る

68

中割り折り

69

中割り折り

70

半分に折る

71

フチを合わせるように折る

72

かぶせ折り

73

70 でつけた折り筋を  
延長するように折る

74

フチを合わせるように折る

75

半分に折る

76

半分に折る

77

73 まで戻す

78

両側で段折り



79

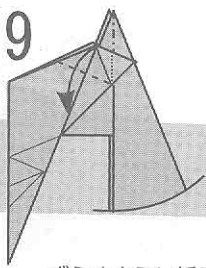

ずらすように折る  
反対側も同様

80

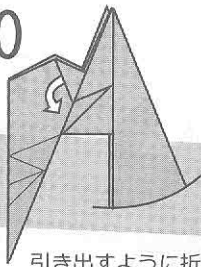

引き出すように折る  
反対側も同様

81

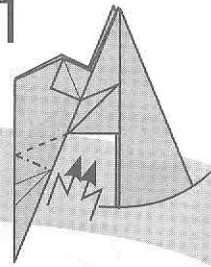

両側で段折り

87

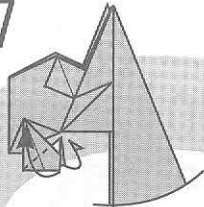

両側で谷折り

86

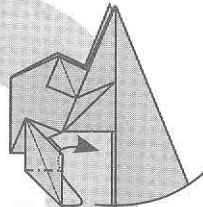

中割り折り

82

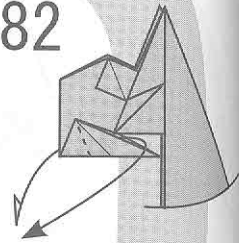

かぶせ折り

88

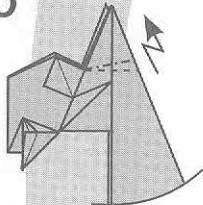

段折り  
反対側も同様

85

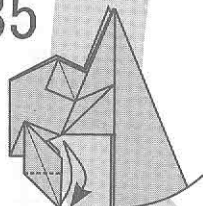

直角に折る

83

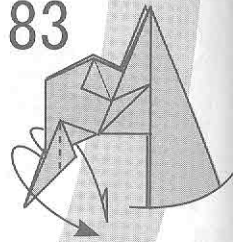

かぶせ折り

89

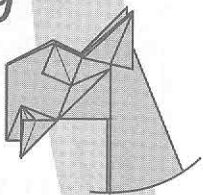

84

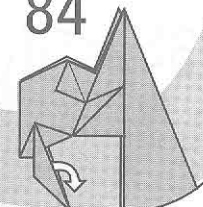

引き出すように折る

90

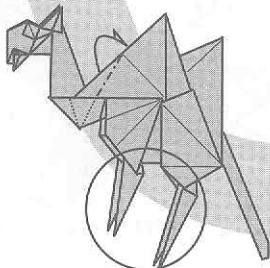

ずらすように折る

91

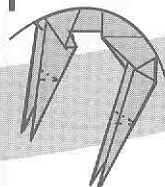

前足は中割り折りを繰り返す  
後足は段折り  
反対側も同様

92

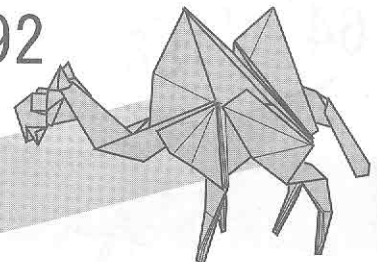

完成

## サイ

Rhinceros

作/図 宮島 登

Models &amp; Diagrams By Noboru MIYAJIMA

創作/2010年5月 作図/2012年10月

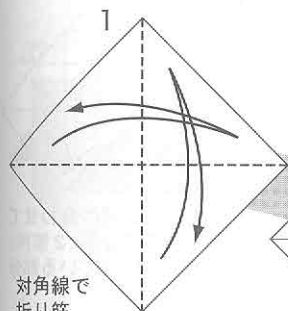
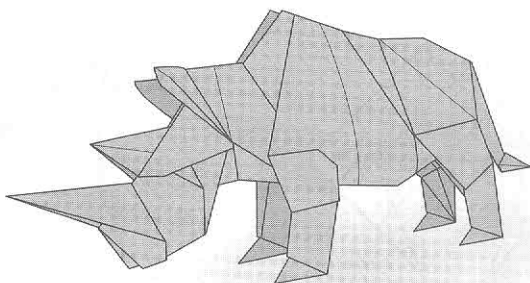

1  
対角線で  
折り筋  
をつける(2箇所)

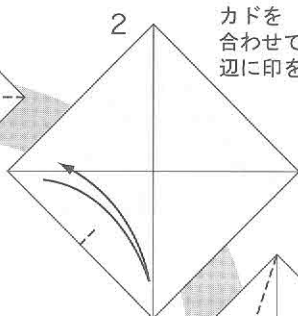

2  
カドを  
合わせて  
辺に印をつける

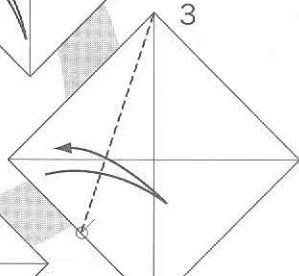

3  
カドと  
○を結ぶ線  
で  
折り筋をつける

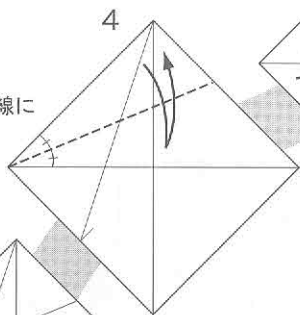

4  
辺を中心線に  
合わせて  
折り筋を  
つける

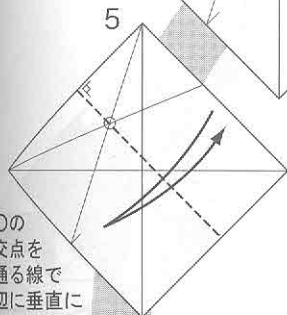

5  
○の  
交点を  
通る線  
で  
辺に垂直に  
折り筋をつける

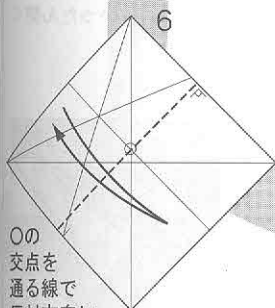

6  
○の  
交点を  
通る線  
で  
反対方向に  
折り筋をつける

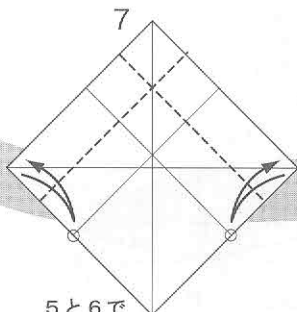

7  
5と6で  
つけた折り筋に  
辺を  
合わせて折り筋をつける

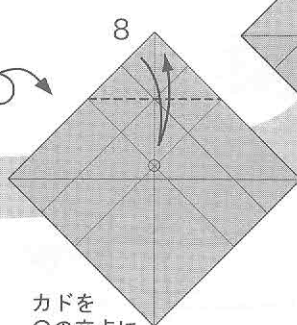

8  
カドを  
○の交点に  
合わせて折り筋をつける

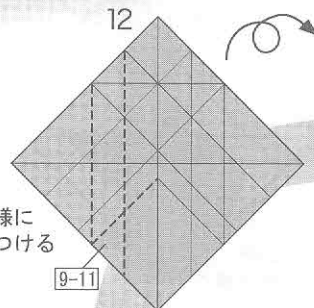

9-11  
左側も同様に  
折り筋をつける  
(9-11)

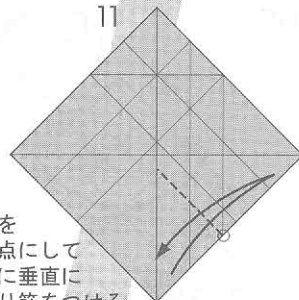

10  
○を  
起点にして  
辺に垂直に  
折り筋をつける  
※折り筋は中心線まででよい

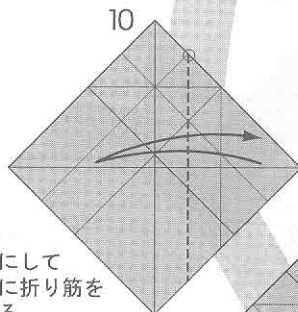

11  
○を  
起点にして  
垂直に折り筋を  
つける

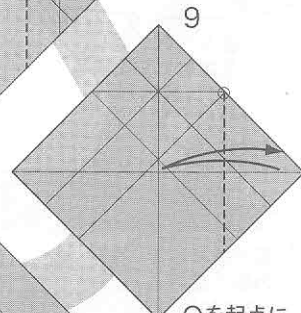

12  
○を起点に  
して垂直に  
折り筋をつける



14 辺を折り筋に合わせて折り筋をつける (2箇所)

15 ○を結ぶ線で折り筋をつける

16 ○に合わせてカドを折り上げる

17 フチを中心線に合わせて折り筋をつける (2箇所) ※紙が重なっている部分だけでよい

18 ○を結ぶ線でフチを折り返す。裏側のカドは表に出す

19

20 ついている折り筋で辺を折り返し、カドはつまみ折り

21 後ろへ折り返し、全体を半分にする

22 図の折り筋で内側を広げる (立体的になる)

23 図の折り筋でカドを折り下げる

24 フチを中心に合わせて平面に置く

25 後ろへ折り返し、全体を半分にする

26 ○を起点にして回転させるように斜めにずらす

27 いったん開く

28 ○を結ぶ線でカドを外側へ折り返す

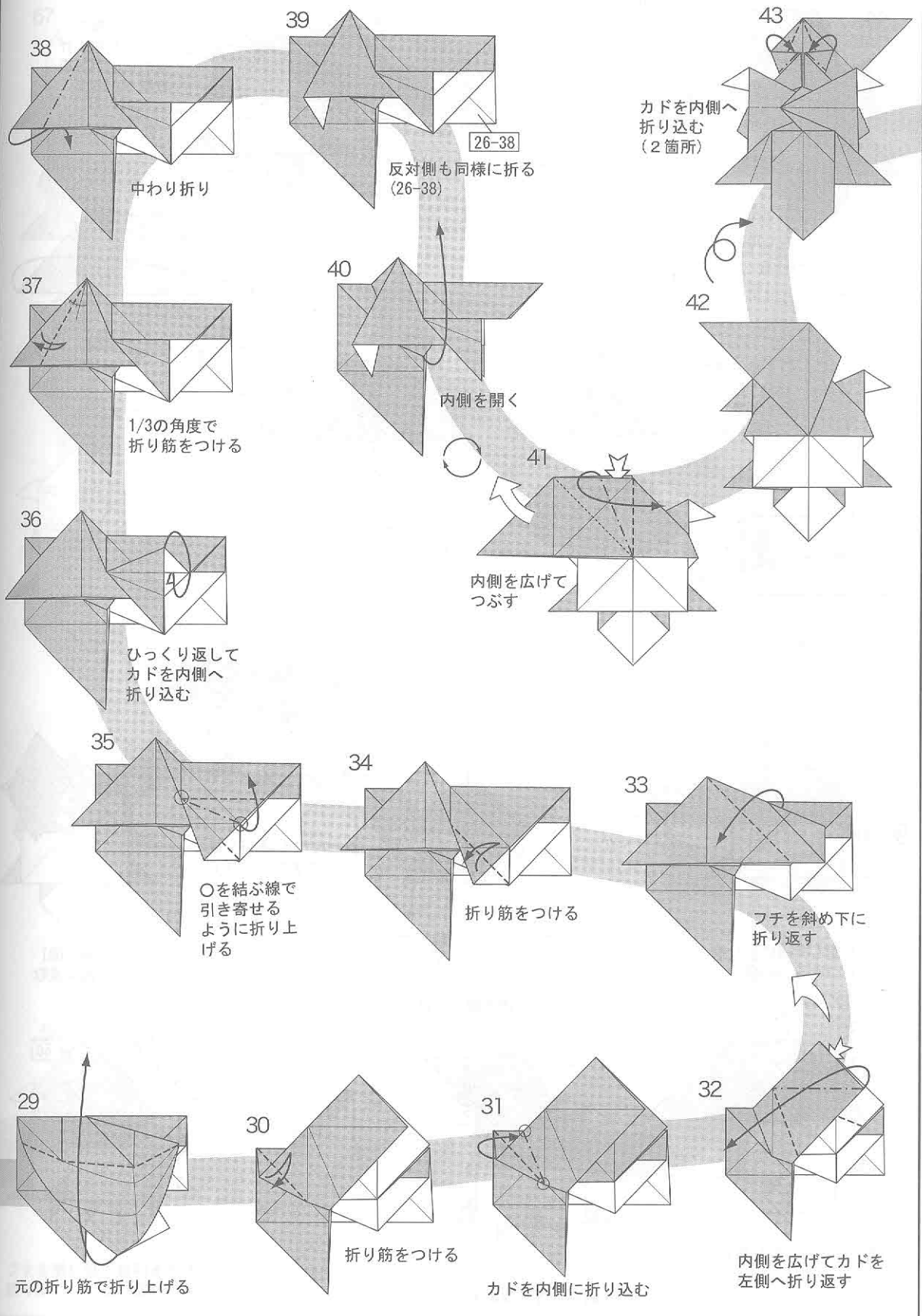

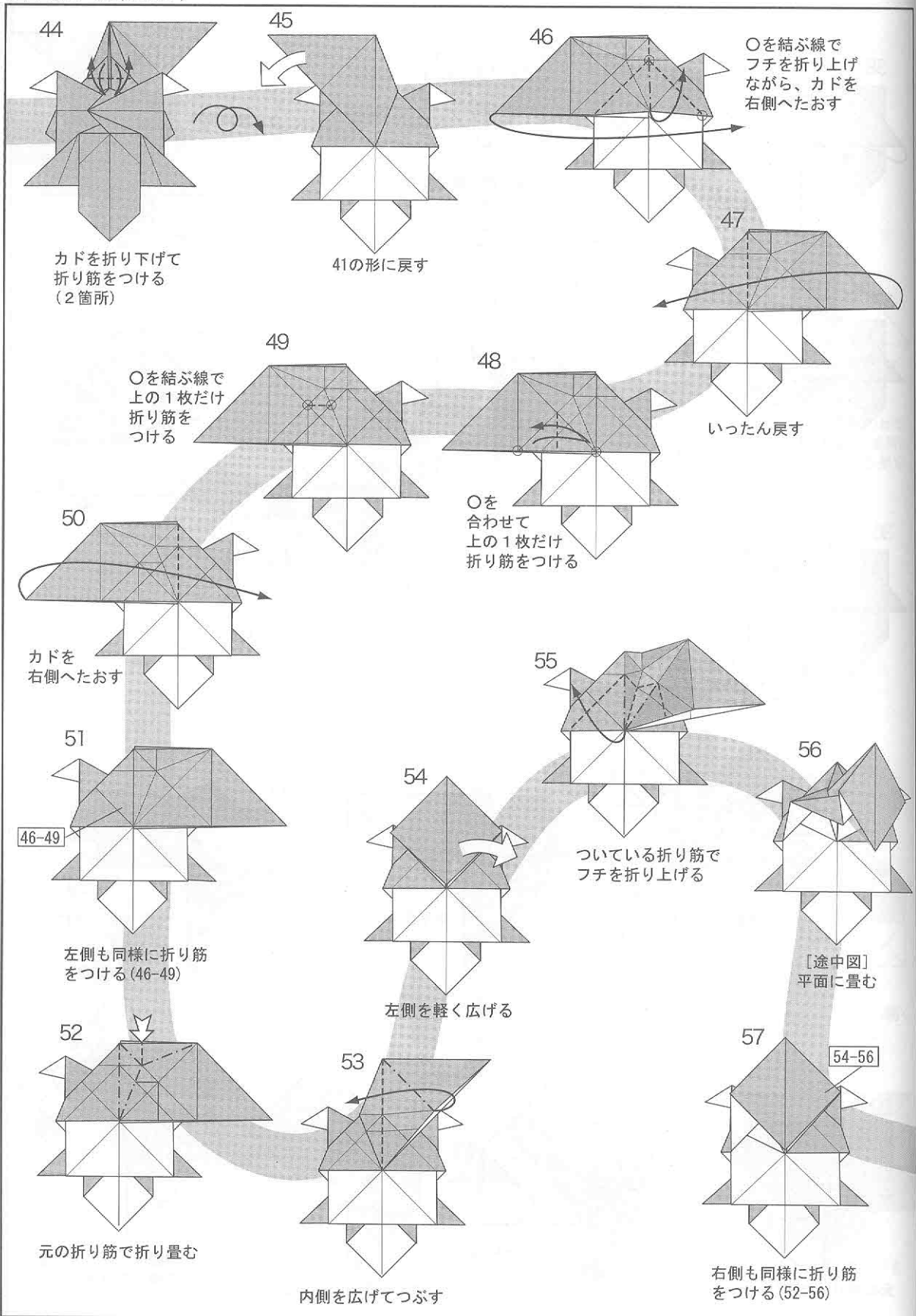

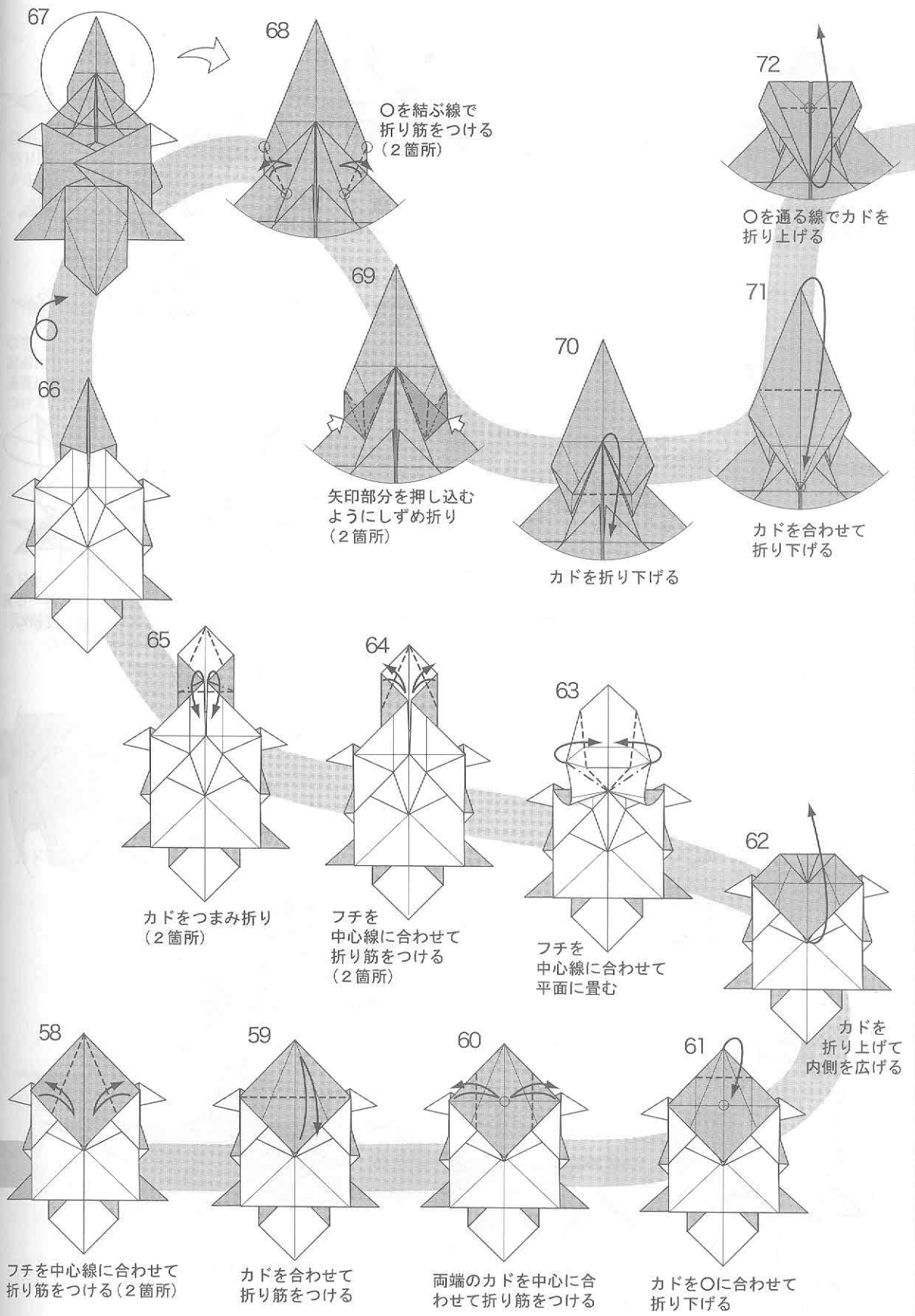

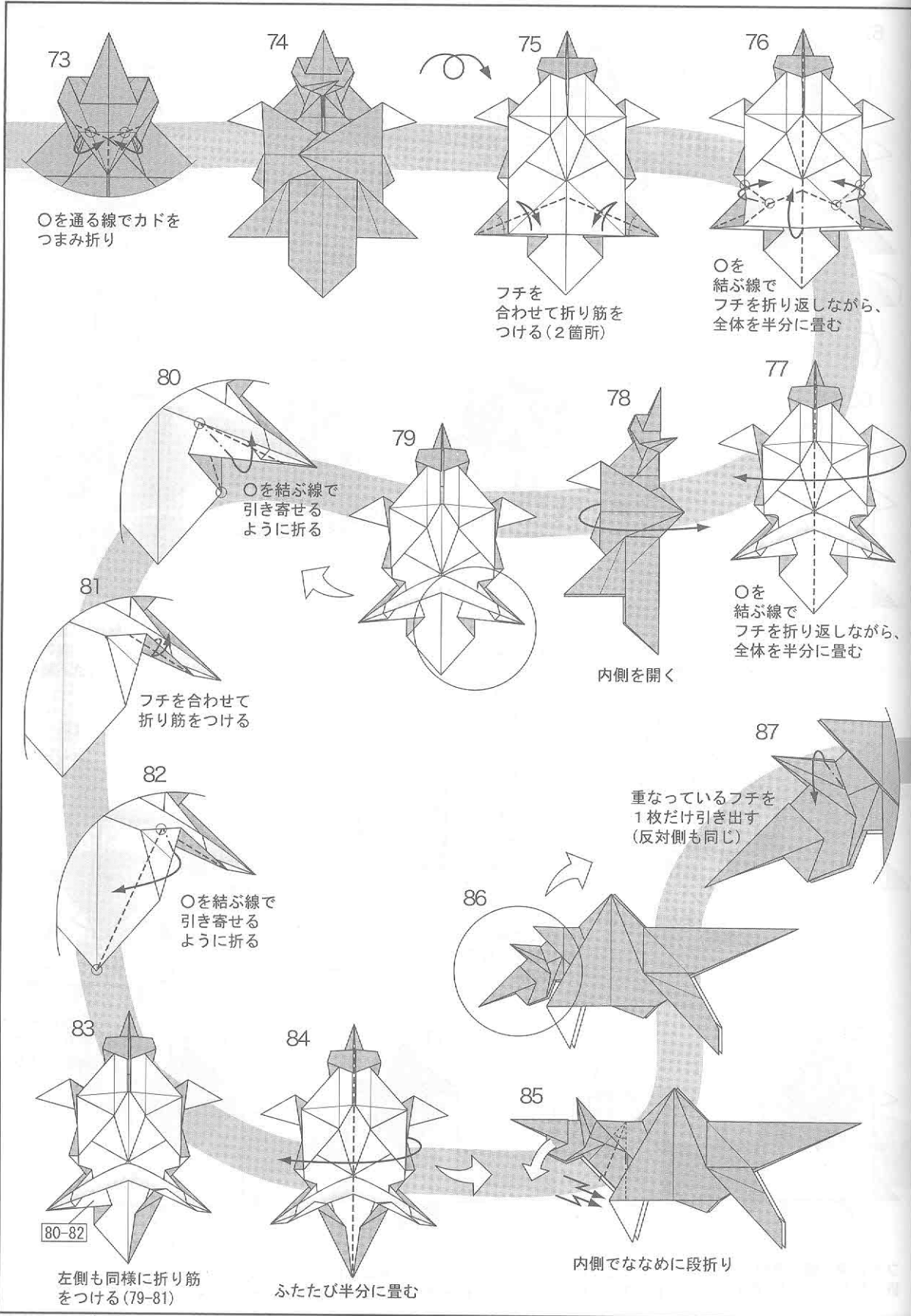

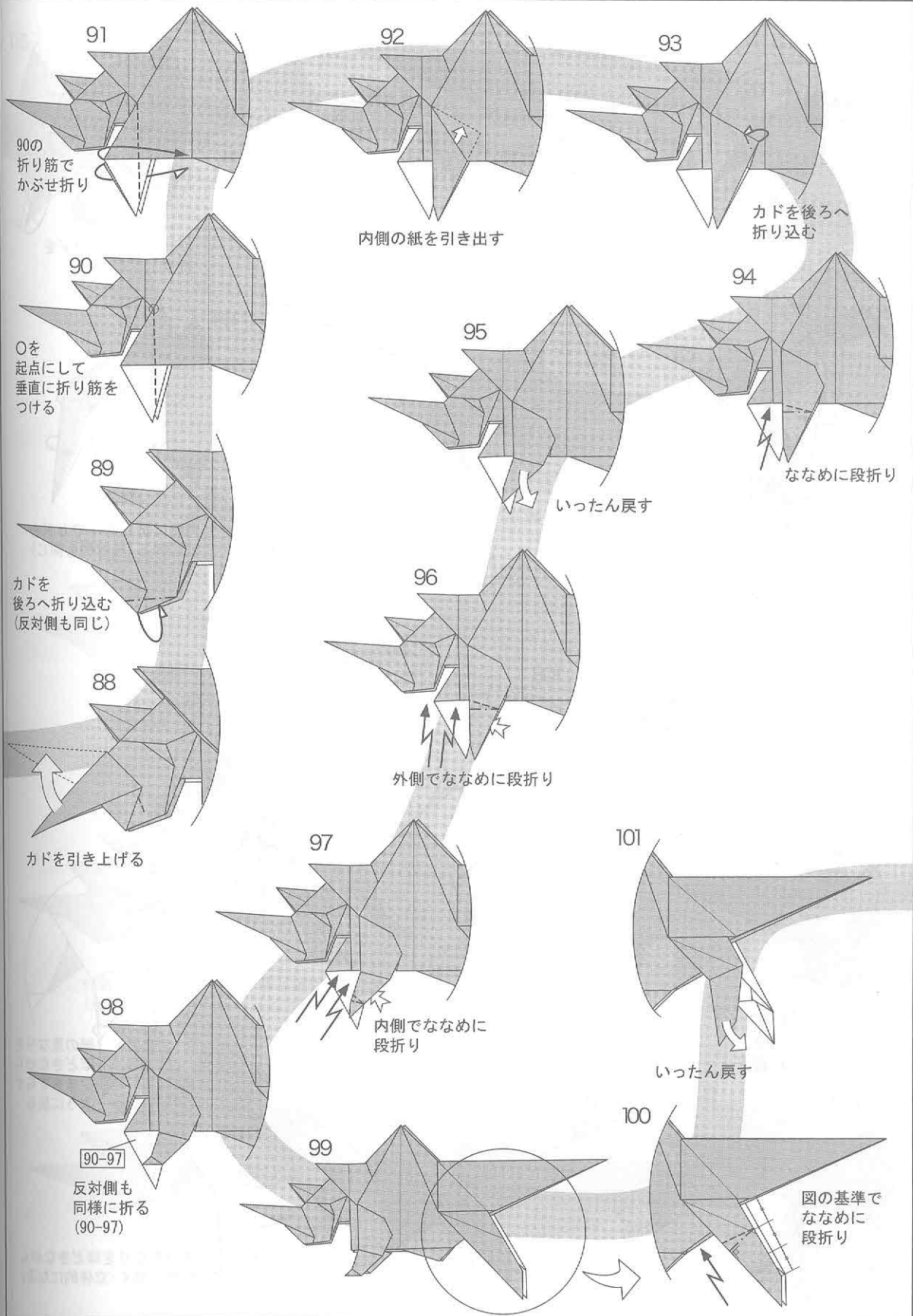



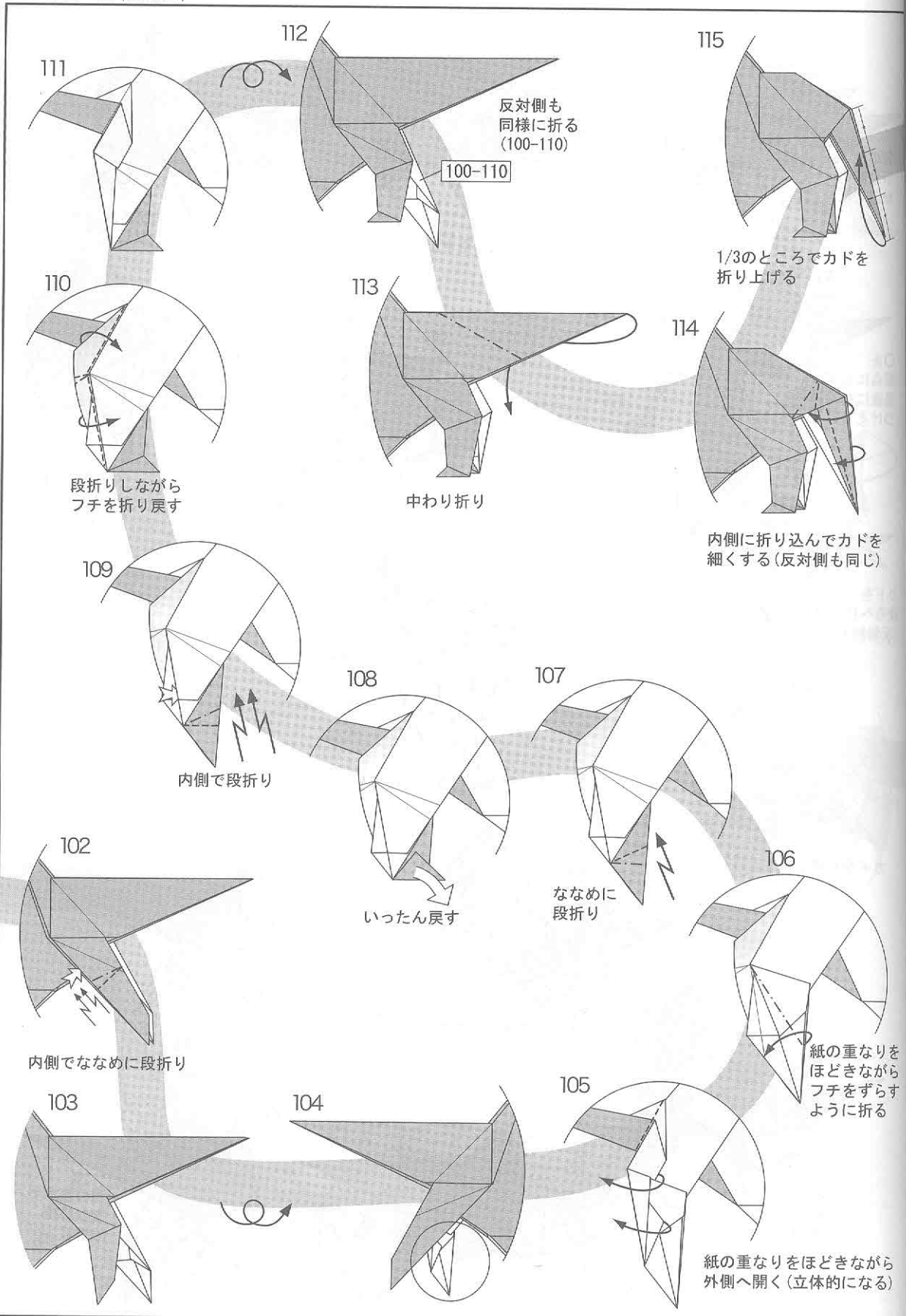

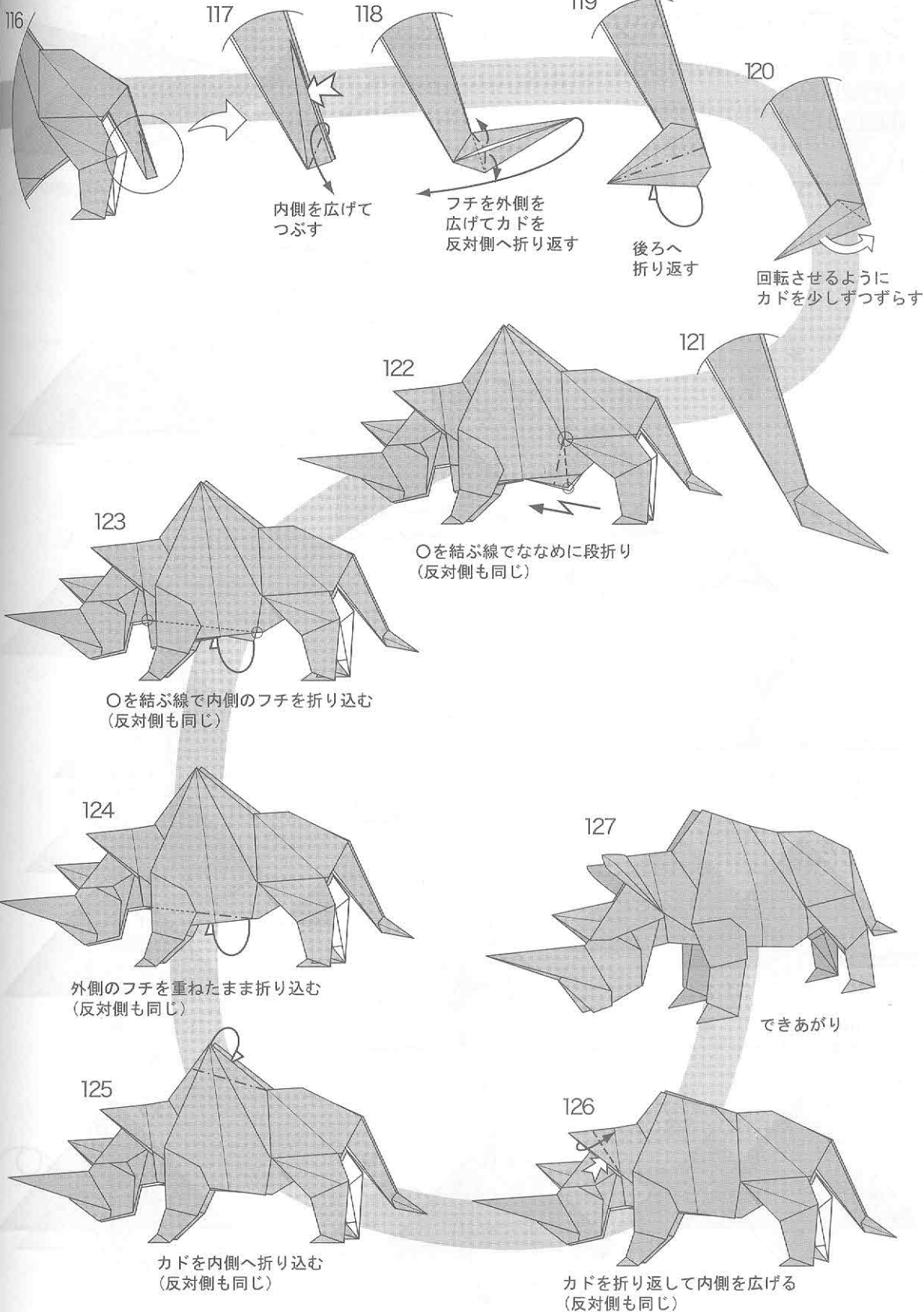

# ショウリョウバッタ Longheaded Locust

村木厚紀 / Atsunori Muraki

創作:2009/x

作図:2013/6

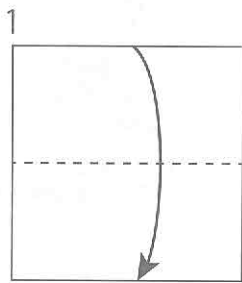
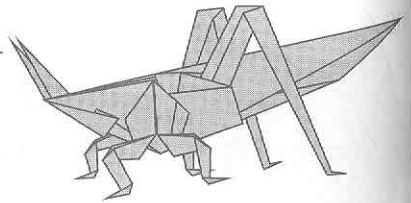

半分に折る

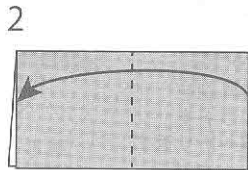

半分に折る

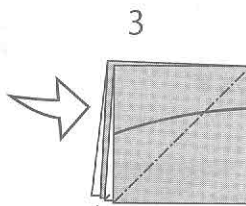

開いて潰す

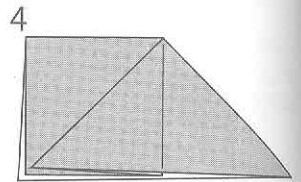

裏返す

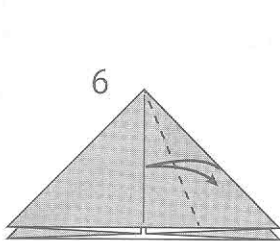

開いて潰す

中心に合わせて  
折すじを付ける

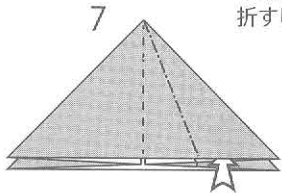

7

開いて潰す

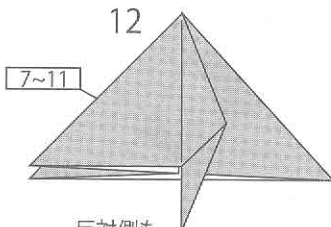

12

7~11

反対側も  
7~11と同様に折る

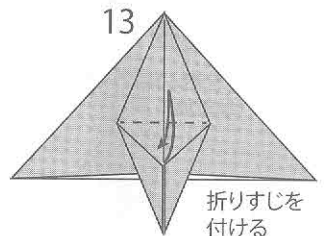

13

折りすじを  
付ける

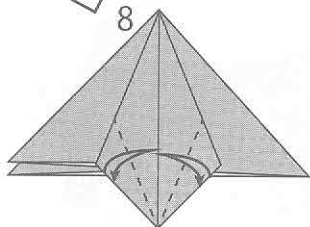

8

中心に合わせて  
折すじを付ける

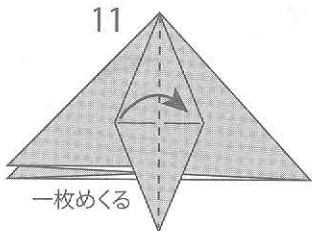

11

一枚めくる

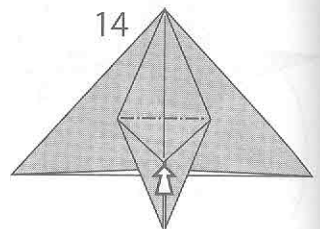

14

角を中に入れる

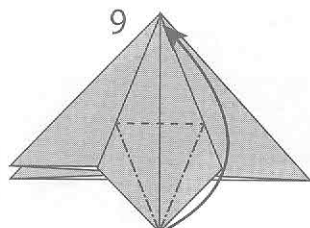

9

広げるように折る

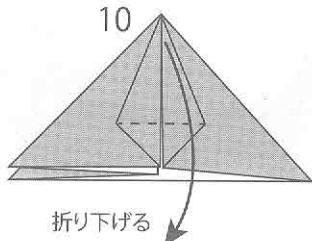

10

折り下げる

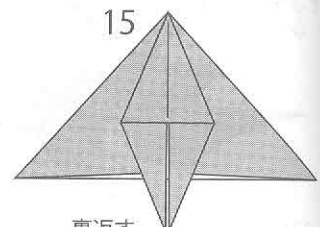

15

裏返す

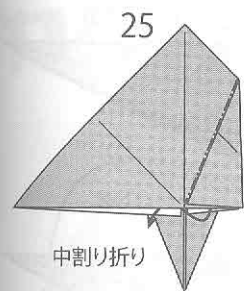

中割り折り

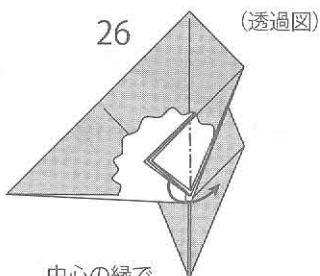

(透過図)

中心の縁で  
中割り折り(3ヶ所)

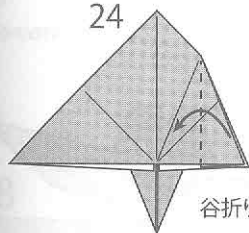
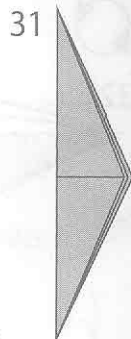

24

谷折り

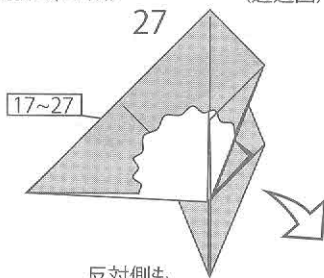

(透過図)

17~27

反対側も  
17~26と同様に折る

全体を  
半分に折る

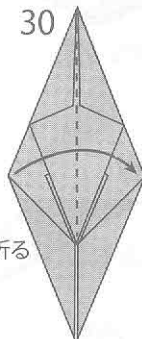

30

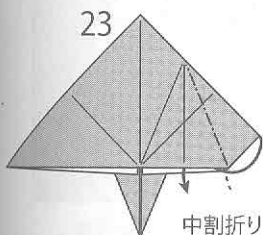

23

中割り折り

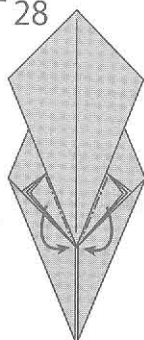

出ている角を  
中割り折り(6ヶ所)

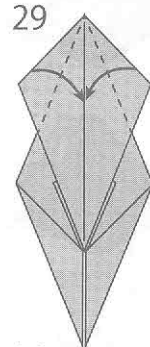

29

中心に  
合わせて折る

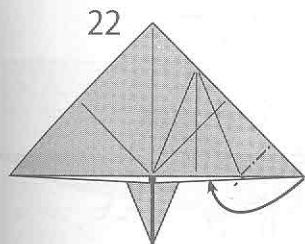

22

内側へ折る

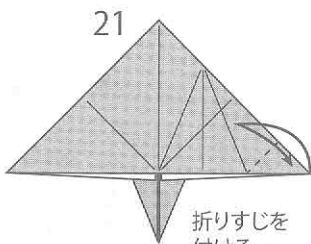

21

折りすじを  
付ける

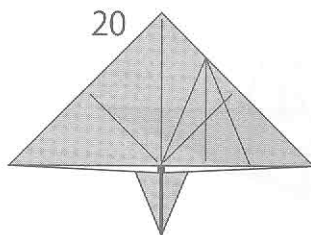

20

16まで戻す

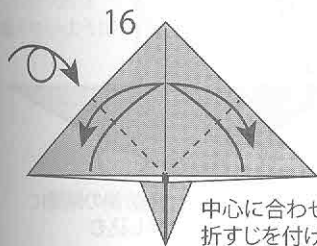

16

中心に合わせて  
折りすじを付ける

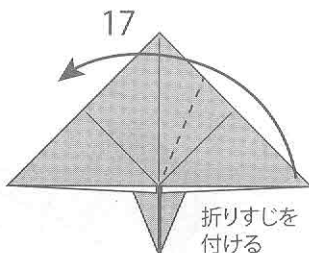

17

折りすじを  
付ける

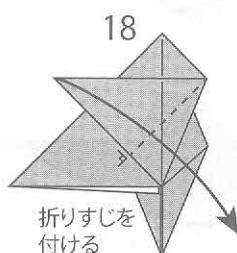

18

折りすじを  
付ける

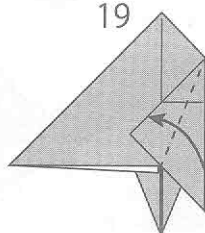

19

折りすじを  
付ける



32

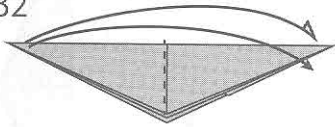

右側に折り返す

33

図を参考につまみ折り

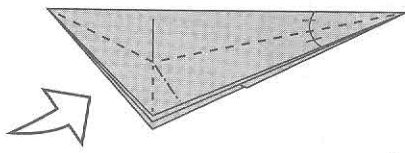

34

反対側も同じ

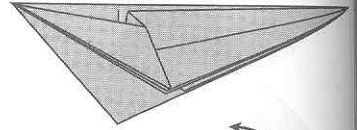

37

足先を折る

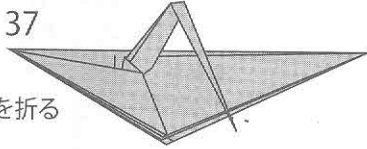

36

かぶせ折り

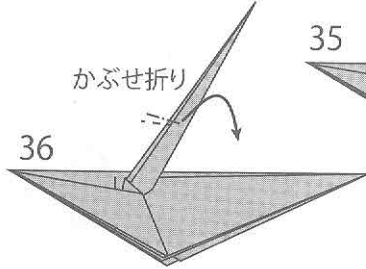

35

角を半分にするように  
つまみ折り

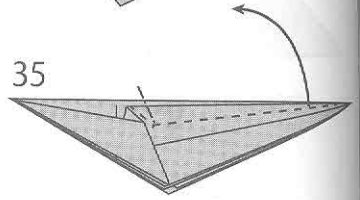

38

一枚めくる

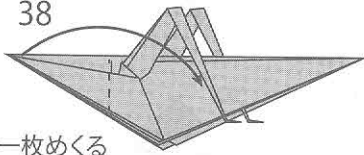

39

つまみ折り

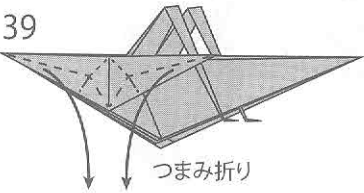

40

かぶせ折り

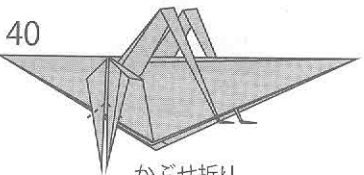

41

かぶせ折り

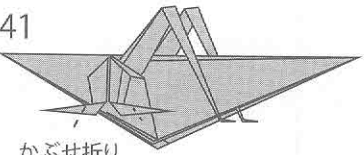

42 [39~42]

反対側も  
39~42  
と同様に折る

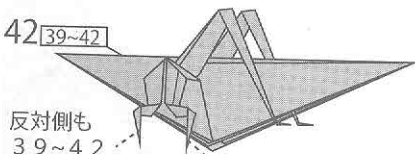

43

表の一枚を  
内側に折る

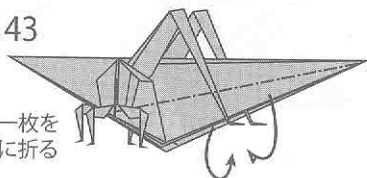

50

触覚を細くする

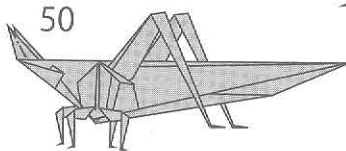

51

完成

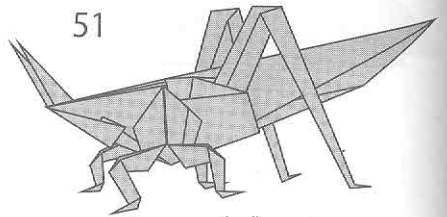

両側から  
かぶせる

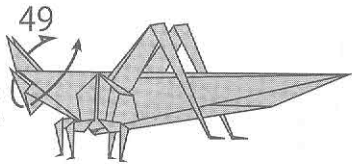

中割折り

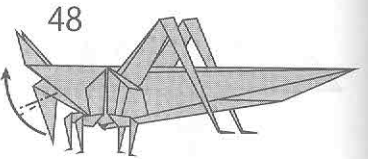

47

中割折り

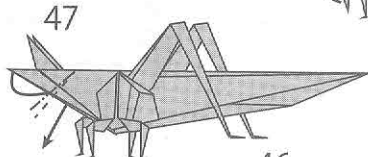

46

内側に折る

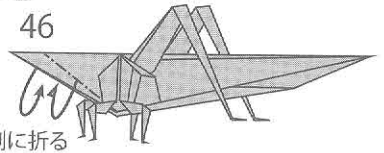

45

図を参考に  
内側に折る

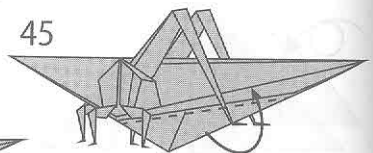

44

手前側の隙間に  
差し込む

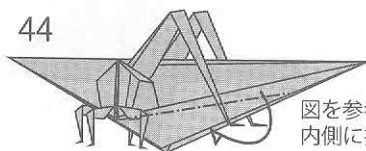

# カタツムリ

作◎小松英夫

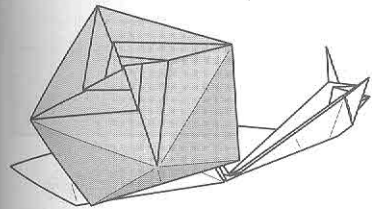

Snail  
by Komatsu Hideo

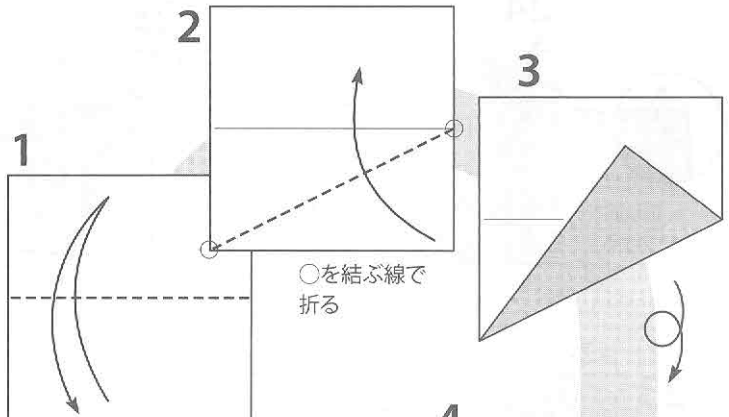

1  
辺を合わせて  
折り筋をつける

○を結ぶ線で  
折る

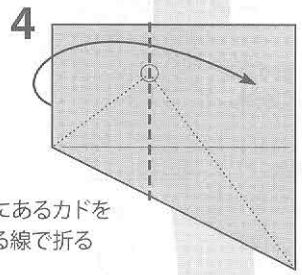
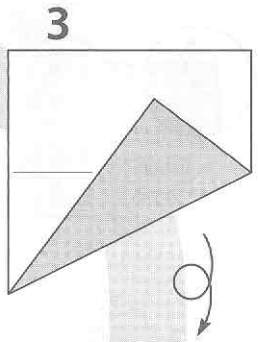

裏にあるカドを  
通る線で折る

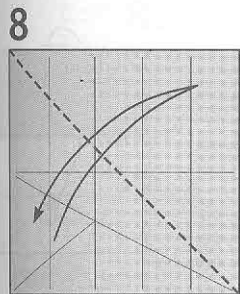

8  
紙の向きに注意して  
折り筋をつける

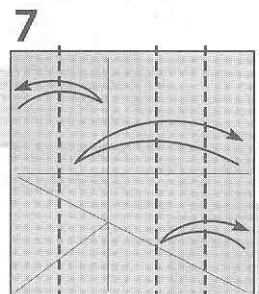

7  
つけた折り筋を基準にして  
5等分の折り筋をつける

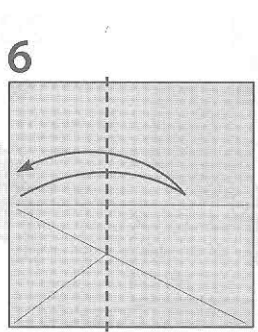

6  
ついている折り筋のところで  
折り筋をつける

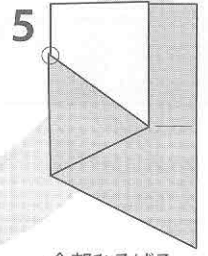

5  
全部ひろげる

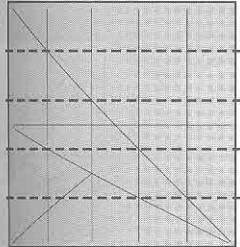

9  
折り筋の  
交点を目安に  
横方向にも  
5等分の  
折り筋をつける

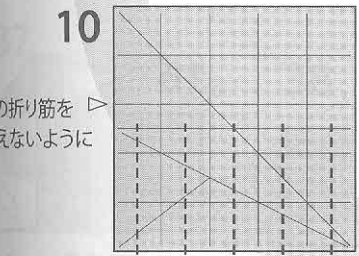

10  
この折り筋を  
越えないように

紙の下半分に 10等分の  
折り筋をつける

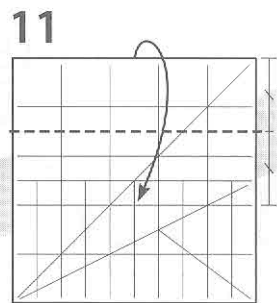

11  
紙の向きに注意して折る

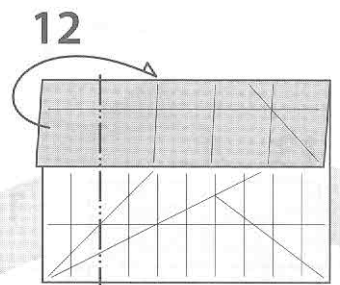

12  
左の 1/5 を  
後ろへ折る

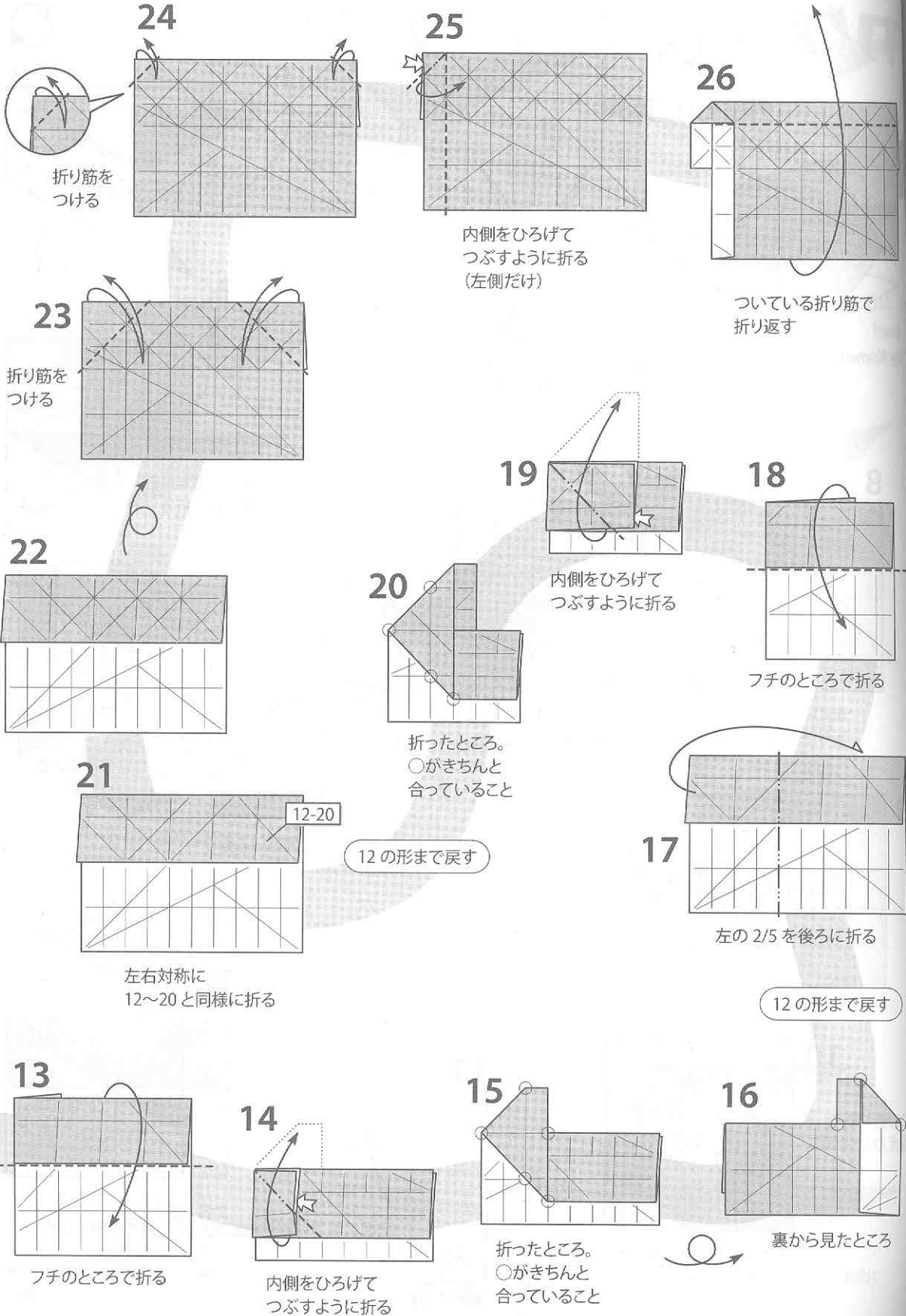

27

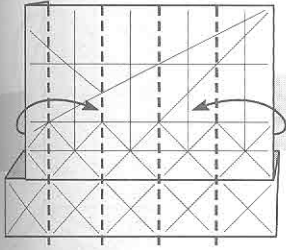

ついている折り筋で  
全体を筒状にする

28

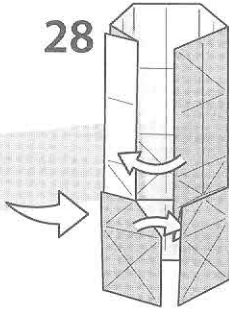

それぞれ端をすき間に  
差し込むようにして、  
四角い筒にする

29

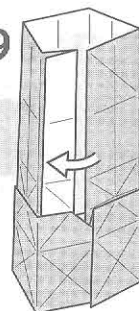

途中の図

30

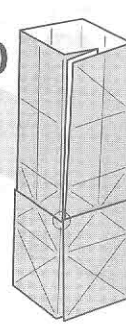

○のところか  
きっちり  
合うように  
奥まで差し込む。  
以下の工程で  
ずれないよう  
気をつけること

断面図

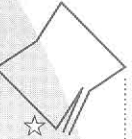

34

ついている折り筋で  
立っているフチを  
平らにするように  
折る

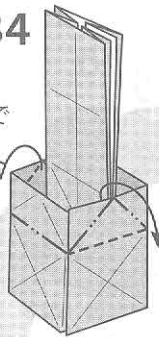

断面図

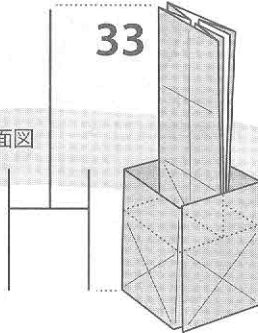

このようになる



下から見たところ

32

ついている折り筋で  
さらにつぶしながら  
下に押し込むように折る

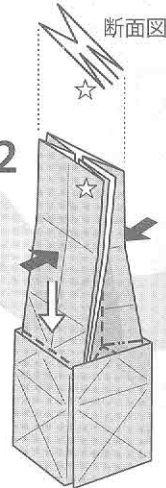

31

ついている  
折り筋で  
筒の上の方を  
つぶすように  
折る

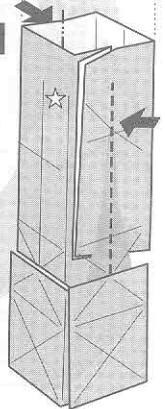

35

上に立っている  
ヒダを手前側に  
倒す

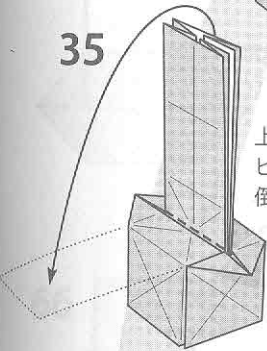

36

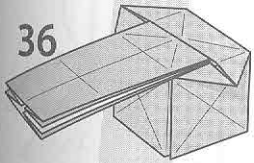

37

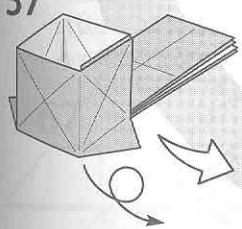

38

ついている折り筋で  
左回りにねじるように  
折りたたむ

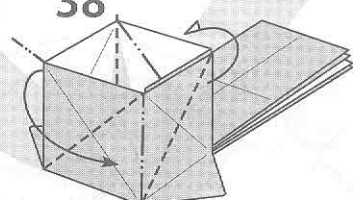

途中の図。

上をすぼめるようにしながら  
一気にヒダを倒すと折りやすい

39

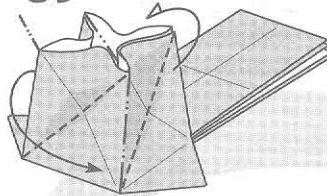

40

次の図は  
上から見る

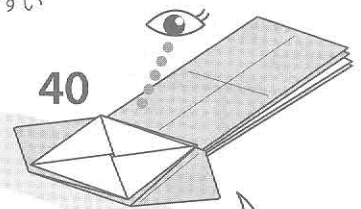

41

フチを合わせて  
折り筋をつける

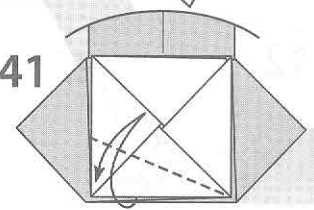



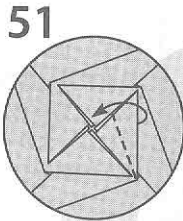

フチとフチを  
合わせて折る

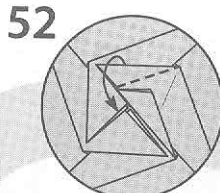

再度、左回りに  
同様に折っていく

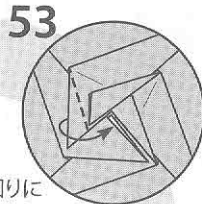

左回りに  
同様に折っていく

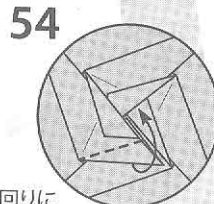

左回りに  
同様に折っていく

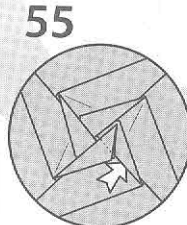

55

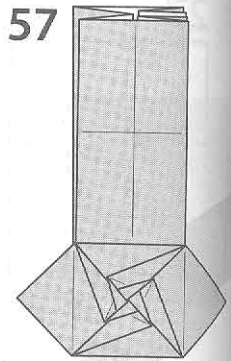

貝殻のうず模様の完成

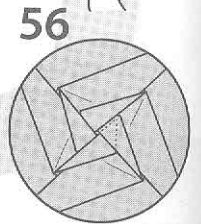

56

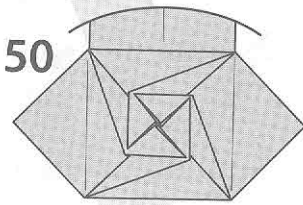

50

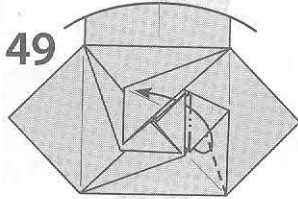

49

最後は、カドの下を  
通すように折る

最後に折ったカドを  
下のすき間に差し込んで  
留める(15cm 四方だと  
ちょっと大変)

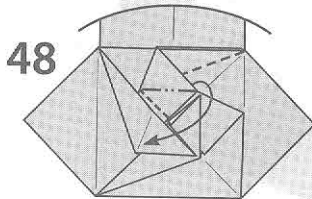

48

右回りに  
同様に折っていく

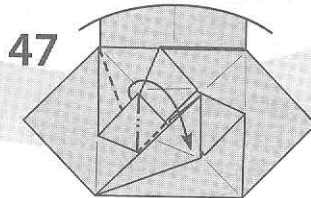

47

今度は右回りに  
同様に折っていく

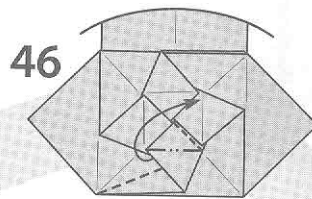

46

カドをつまむ  
ように折る

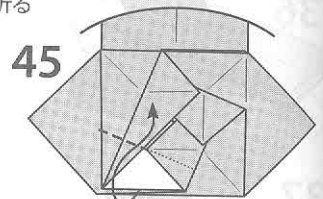

45

最後は 41 でつけた  
折り筋で内側も  
きれいに折り込

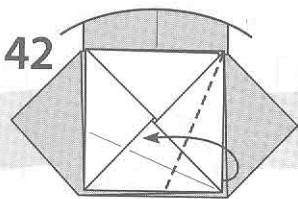

42

フチを合わせて  
折る

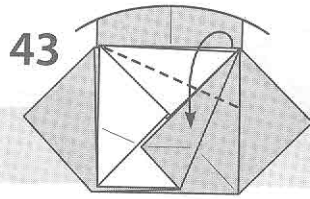

43

左回りに  
同様に折っていく

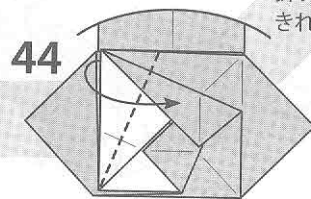

44

左回りに  
同様に折っていく

58

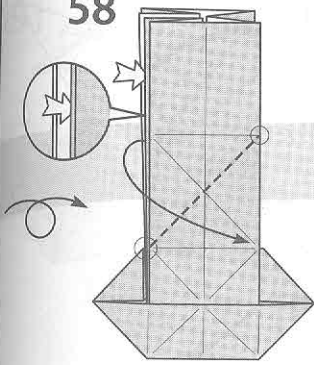

内側をひらくように  
○を結ぶ線で折る

59

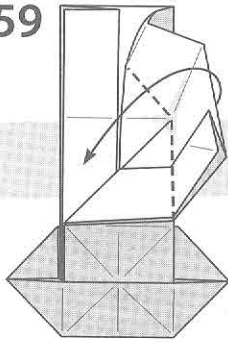

ついている折り筋で  
後ろのフチに沿って  
折り返す

60

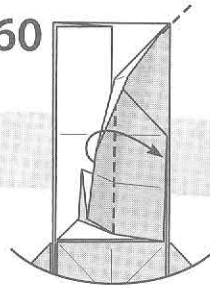

フチを合わせて  
折りたたむ

61

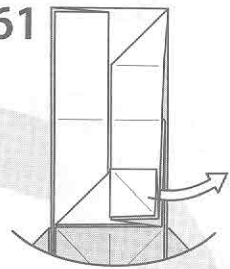

段折り部分を  
少しひろげる

62

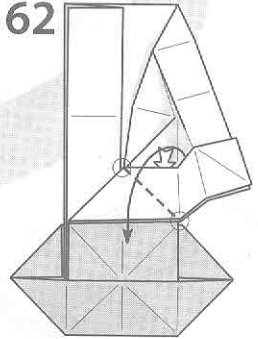

○を結ぶ線で  
折り返す

65

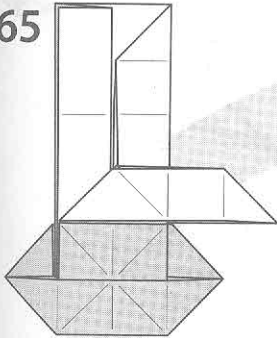

64

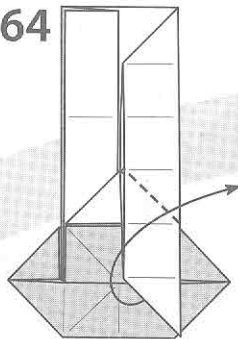

カドのつけ根で  
折り返す

63

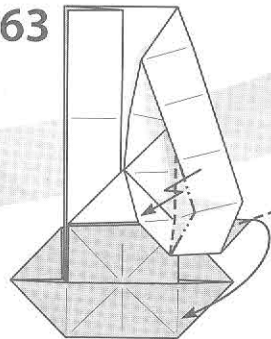

カドを伸ばすように  
折りたたむ

66

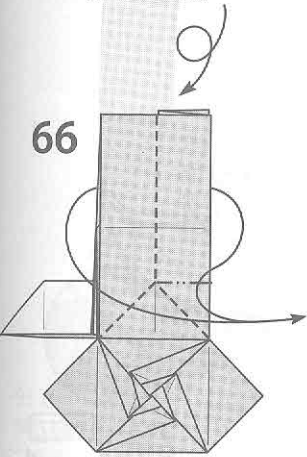

カドをつけ根から  
つまむように折る

70

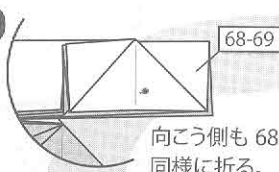

向こう側も 68~69と  
同様に折る。  
(紙の重なりが少ないが、  
形は同じ)

71

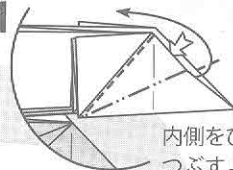

内側をひろげて  
つぶすように折る

69

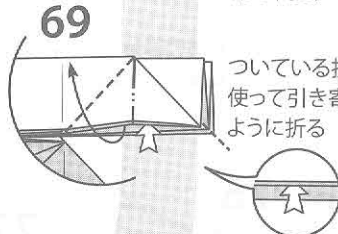

ついている折り筋を  
使って引き寄せる  
ように折る

上に2枚

72

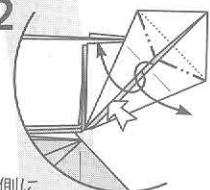

両側に  
ひらいてつぶすように折る

67

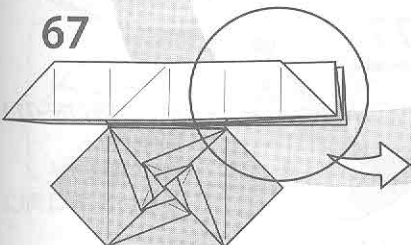

68

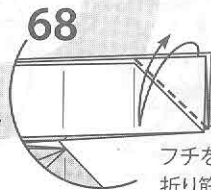

フチを合わせて  
折り筋をつける

73

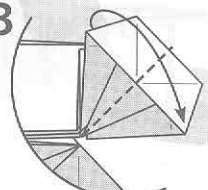

閉じるように折る

**74** 折り込むように中割り折り

**75** 向こう側も 74 と同様に折る

**76** 花弁折りのように折る

**77** 閉じるように折る

**78** 向こう側も 76~77 と同様に折る。(紙の重なりが少ないが、形は同じ)

**79**

**80** 貝殻の部分を水平にする。以降は立体図になる

**81** 貝殻を箱状に立体化する

**82** 反対側に折り返す

**83** 右側のすき間を折り返してひらき、左側にかぶせるように折る

**84** 途中の図。白いカドをまとめて手前に引き上げる

**85** このようになる。実際に折ったものはこの図ほど安定した状態にはならないが問題ない

箱の中にピラミッドがあるような形

**86** 以降の図では便宜的に箱部分の側面を描画しない

**87** 紙の重なりを外してカドを伸ばすように引き出す

**88** 次の図は見る向きが変わる

**89** 手前のカドを斜めに段折り

**90** 1枚だけ引き出しながら折り返す

91

次の図は  
見る向きが  
変わる

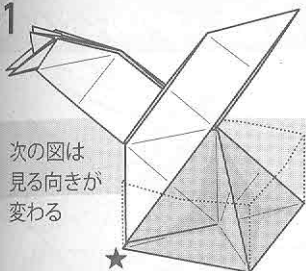

92

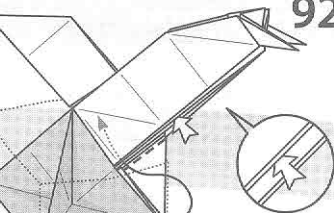

90で折り返したカドを  
真ん中のすき間に  
差し込むように折る

93

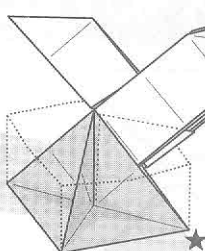

以降の図は  
箱部分を  
再び描画する

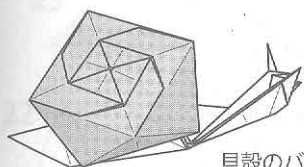

貝殻のバリエーション例

94

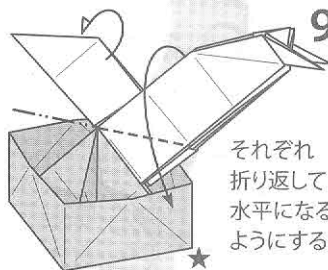

それぞれ  
折り返して  
水平になる  
ようにする

95

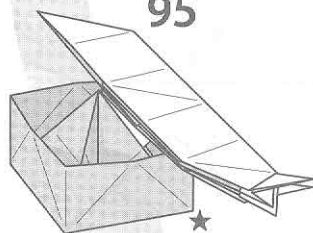

側面が  
直角二等辺三角形の  
反四角柱

★102

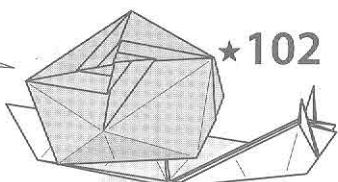

できあがり

★101

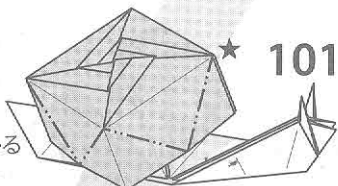

ついている  
折り筋で  
箱(貝殻)の下のフチを  
斜めの正方形にする

96

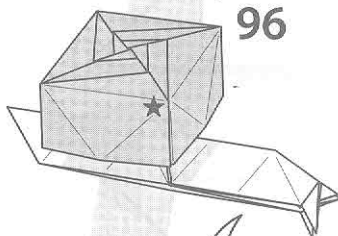

97

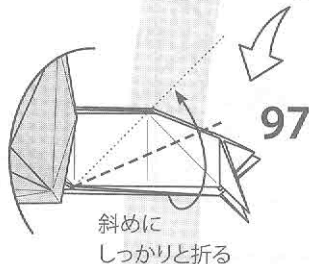

斜めに  
しっかりと折る

95と  
同じ視点の図。  
フチのところで  
かるく山に折る

★100

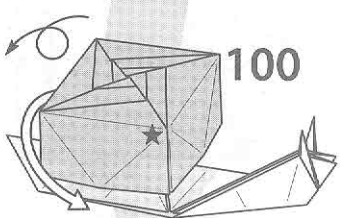

貝殻の位置を、下の図のように調整する

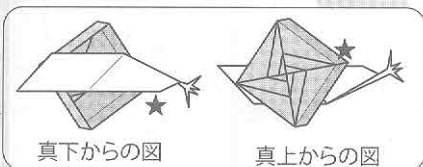

真下からの図

真上からの図

99

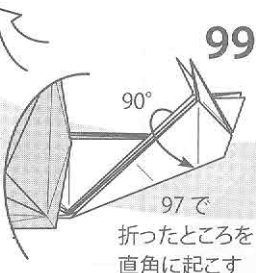

90°

97で  
折ったところを  
直角に起こす

98

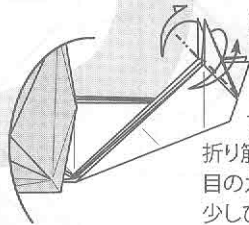

フチのところで  
折り筋をつけて  
目のカドが  
少しひらくようにする

# プレシオサウルス Plesiosaurus

創作・折り図：青木 良

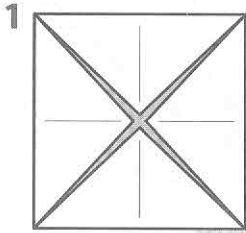

オモテが中になるように  
ざぶとん基本形を折って  
はじめます

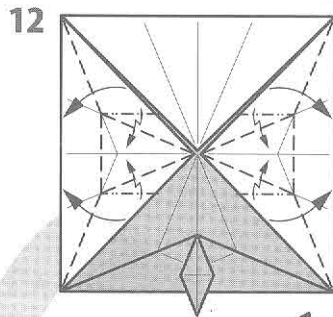
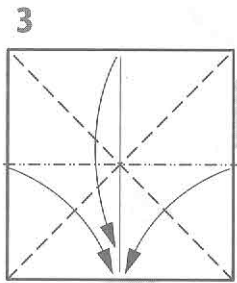
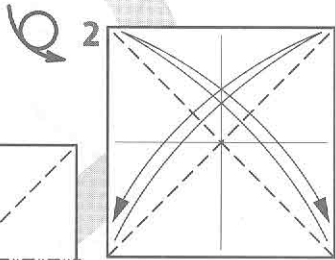
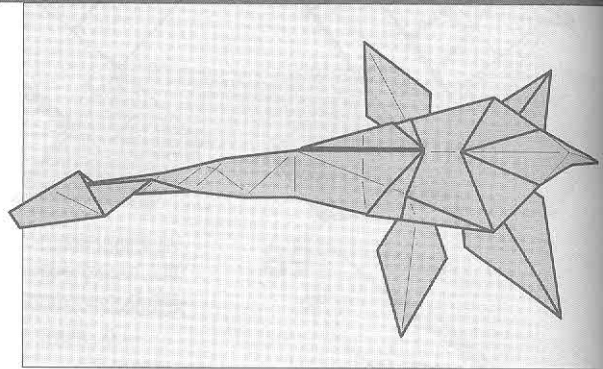

よせるように  
折りたたみます

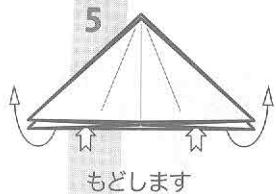
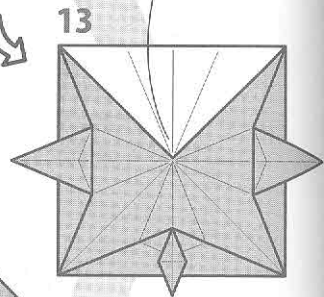
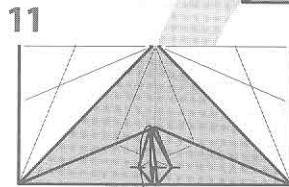
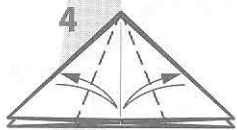

もどします

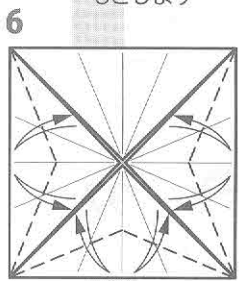
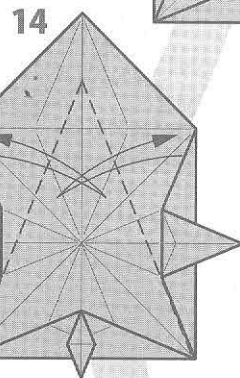
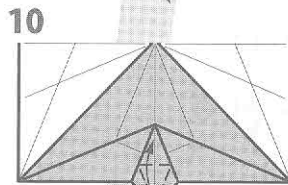

開いて折りたたみます

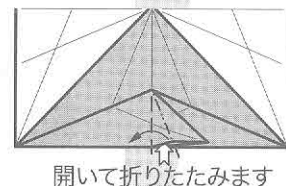

開いて折りたたみます

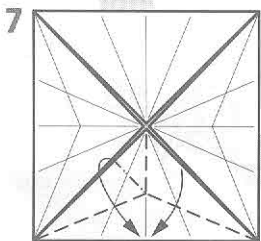

つまむように折り  
たたみます

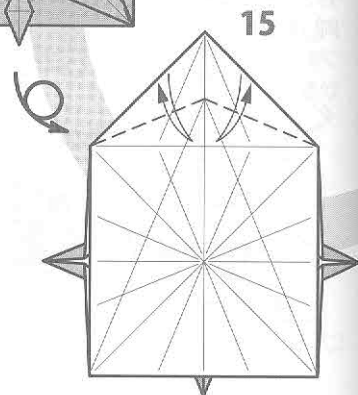
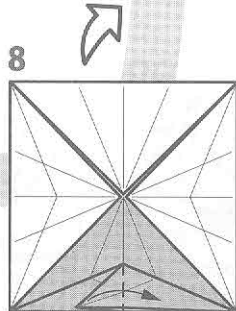

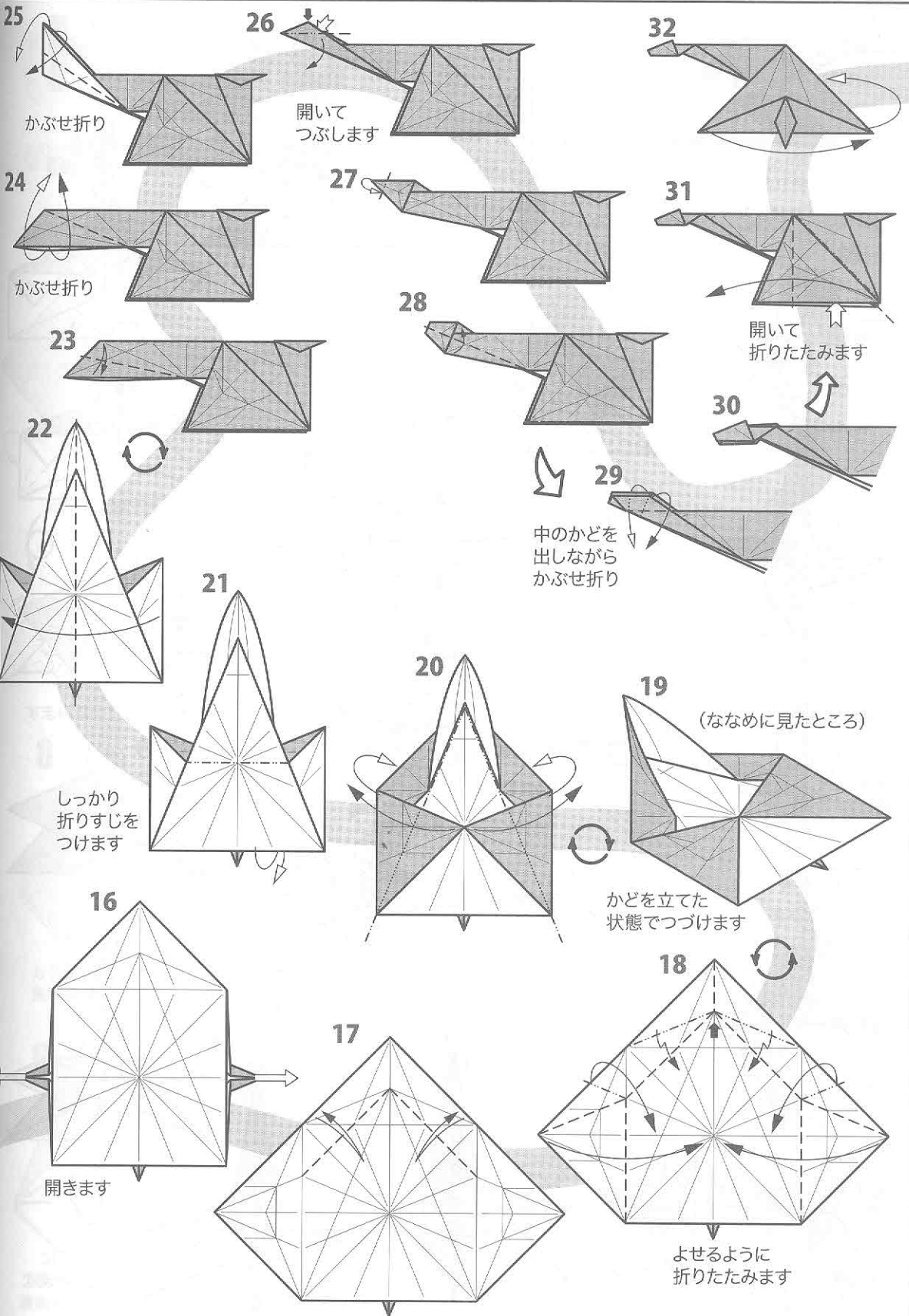

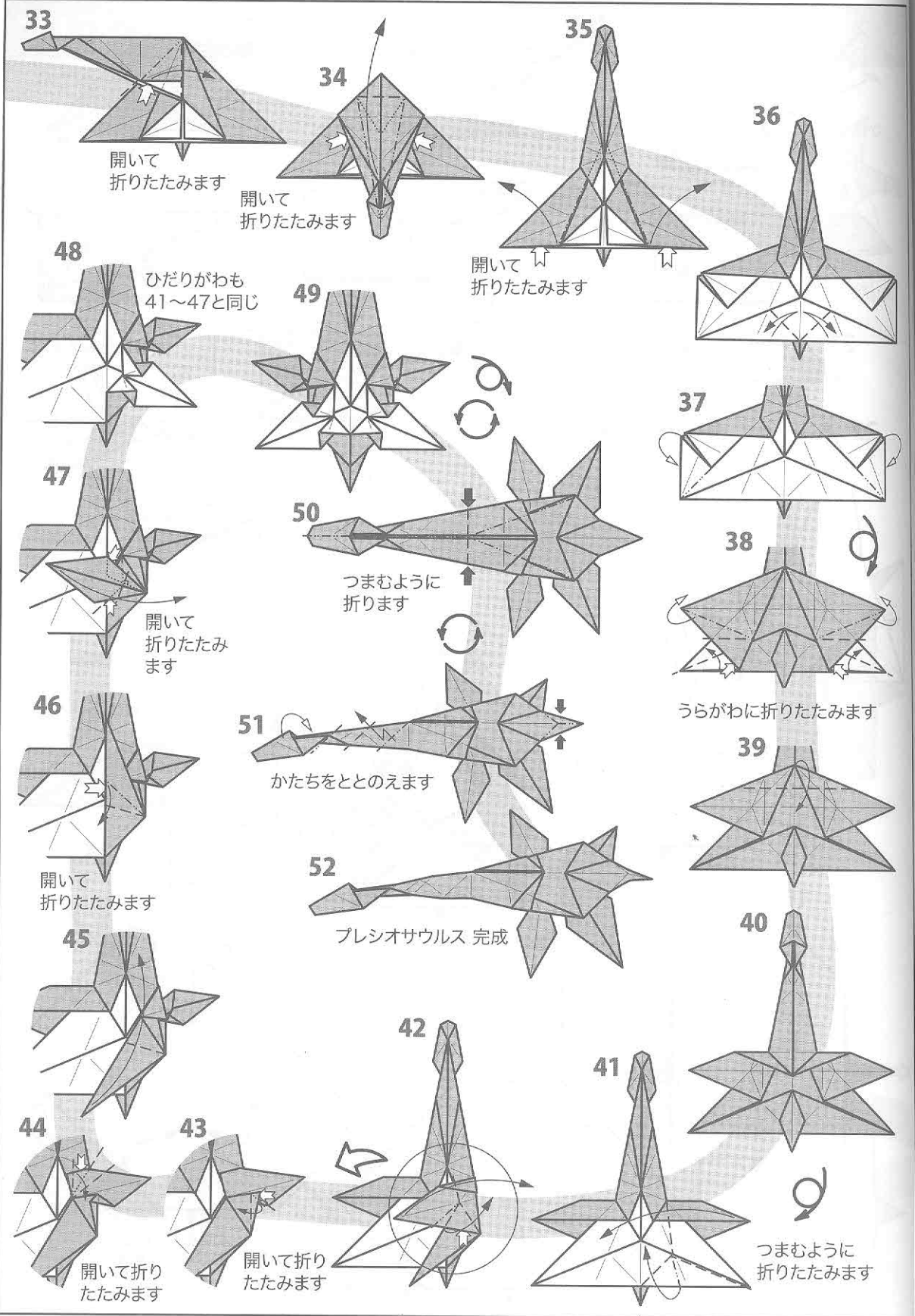

# ドラゴン

## Dragon

創作・作図 キノシタゴウ  
Design&diagrams by Go Kinoshita

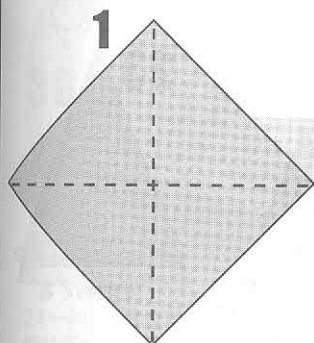
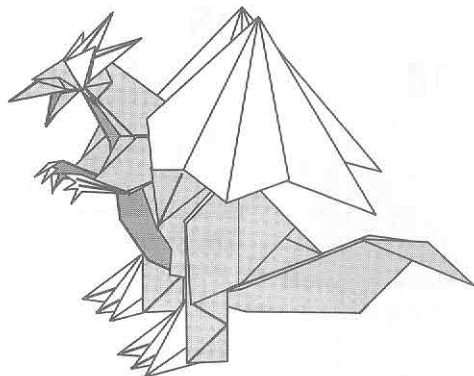

1 折り筋をつける

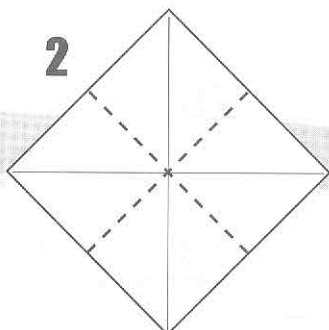

2 折り筋をつける

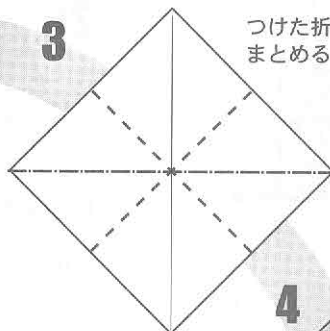

3 つけた折り筋で  
まとめる

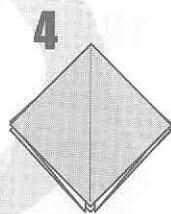

4 正方基本形

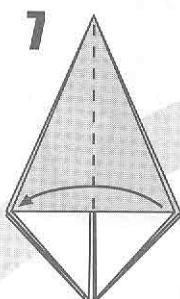

7 1枚めくる  
裏側も同じ

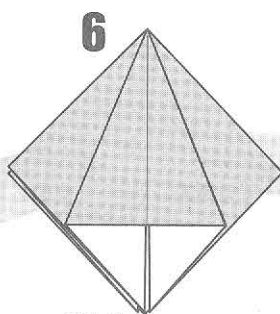

6 残りの  
3カ所も同じ

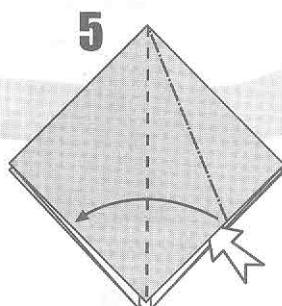

5 開いてつぶす

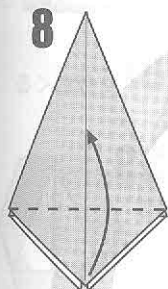

8 カドを折り上げる  
裏側も同じ

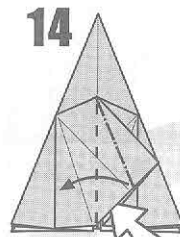

14 開いて  
つぶす

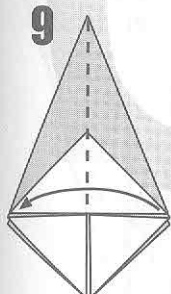

9 2枚めくる  
裏側も同じ

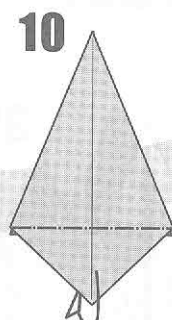

10 すぐ下に折りこむ  
裏側も同じ

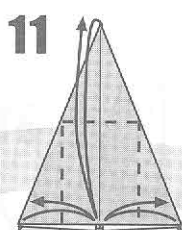

11 折り筋をつける  
左右の折り筋は  
一番上の紙だけ

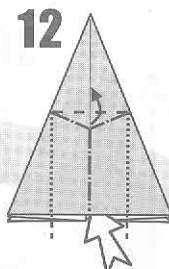

12 つけた折り筋で  
つまむように  
折る

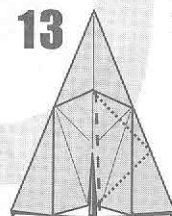

13 立体図……  
つまんだカドを  
倒して平面にする



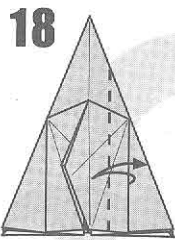

18 折り筋をつける

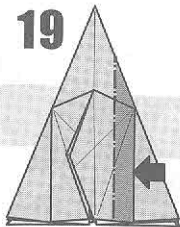

19 濃い色の部分を closed-sink

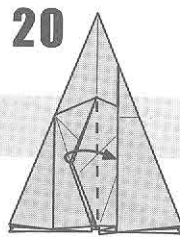

20 1枚めくる

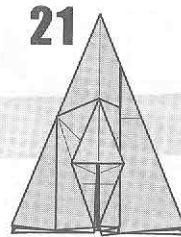

21 反対側も17~20と同じ

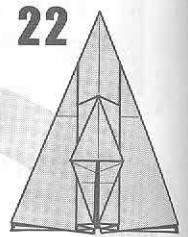

22

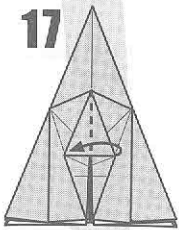

17 1枚めくる

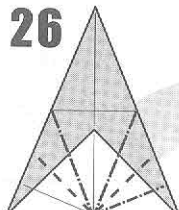

26 つけた折り筋で 中割り折り 右は3回左は2回

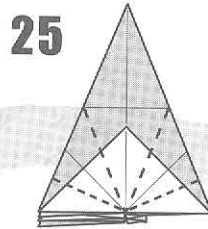

25 折り筋をつける

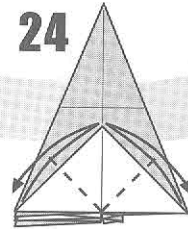

24 折り筋をつける

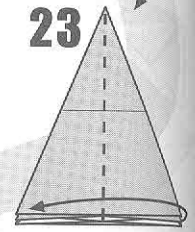

23 2枚めくる

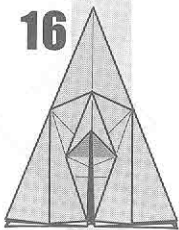

16 濃い色の部分を 中にしまう

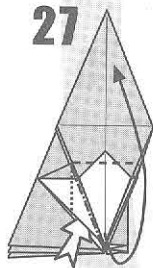

27 開いてつぶす

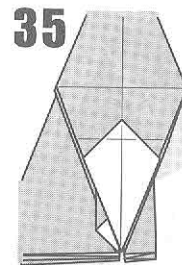

35

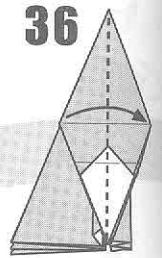

36

2枚めくる

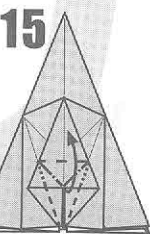

15 開いてつぶす

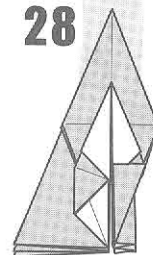

28

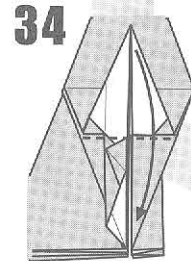

34

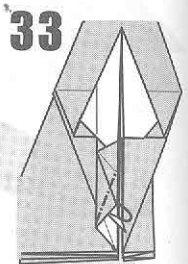

33

中に折り込む

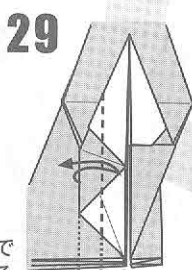

29

図のような幅で 折り筋をつける (少々つけづらい)

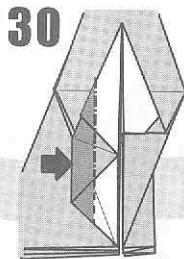

30

つけた折り筋で 濃い色の部分を open sink

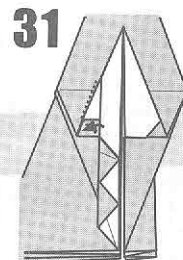

31

白いカドを引き出す

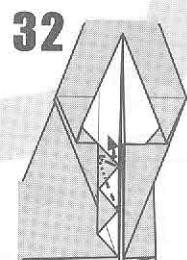

32

引き寄せ折り

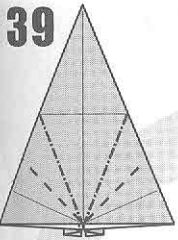

39 左右2回ずつ  
中割り折り

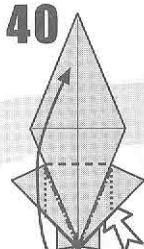

40 開いてつぶす

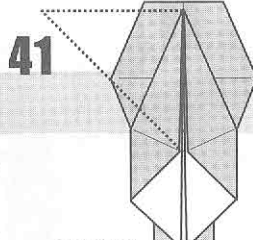

41 内側から  
カドを引き出す

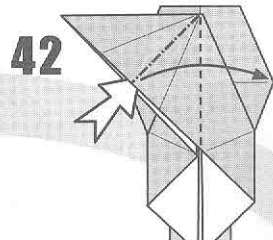

42 開いてつぶす

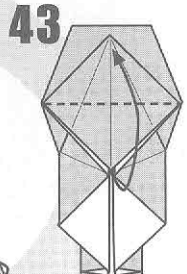

43 カドを  
折り上げる

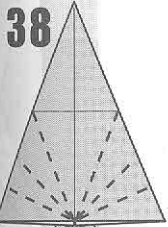

38 24~25 と同じように  
折り筋をつける

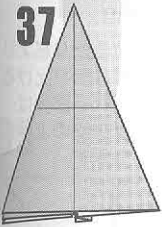

37 反対側も23~36と  
同じ

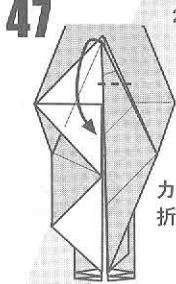

47 カドを  
折り下げる

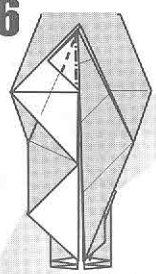

46 2回中割り折り

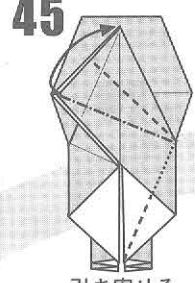

45 引き寄せる  
ように折る

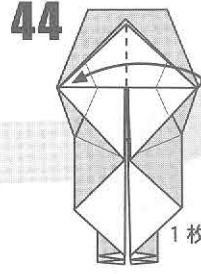

44 1枚めくる

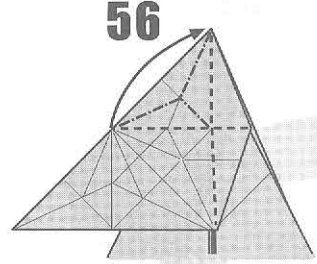

56 ついている折り筋で  
図のようにまとめる

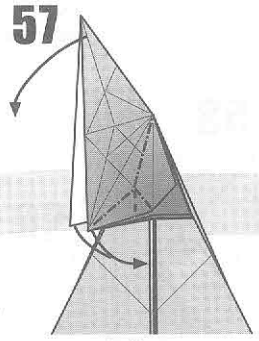

57 立体図……

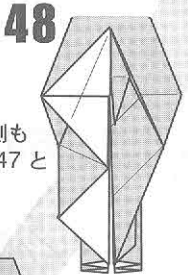

48 反対側も  
44~47と  
同じ

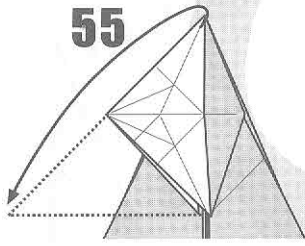

55 カドをほどく

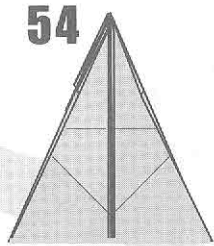

54 51 まで戻す

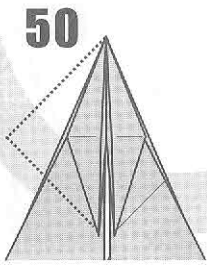
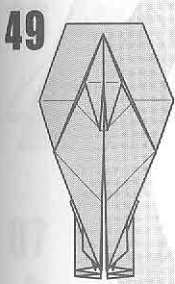

50 内側からカドを引き出す

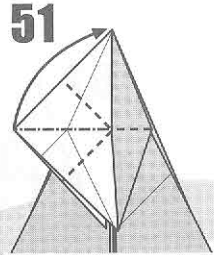

51 カドをまとめて  
折り上げる

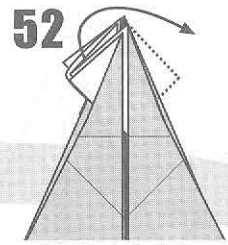

52 畳まれたカドを  
中割り折りですす

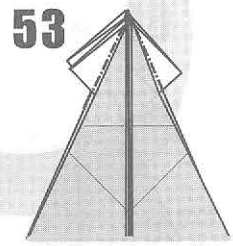

53 3つのカドを中割り折り

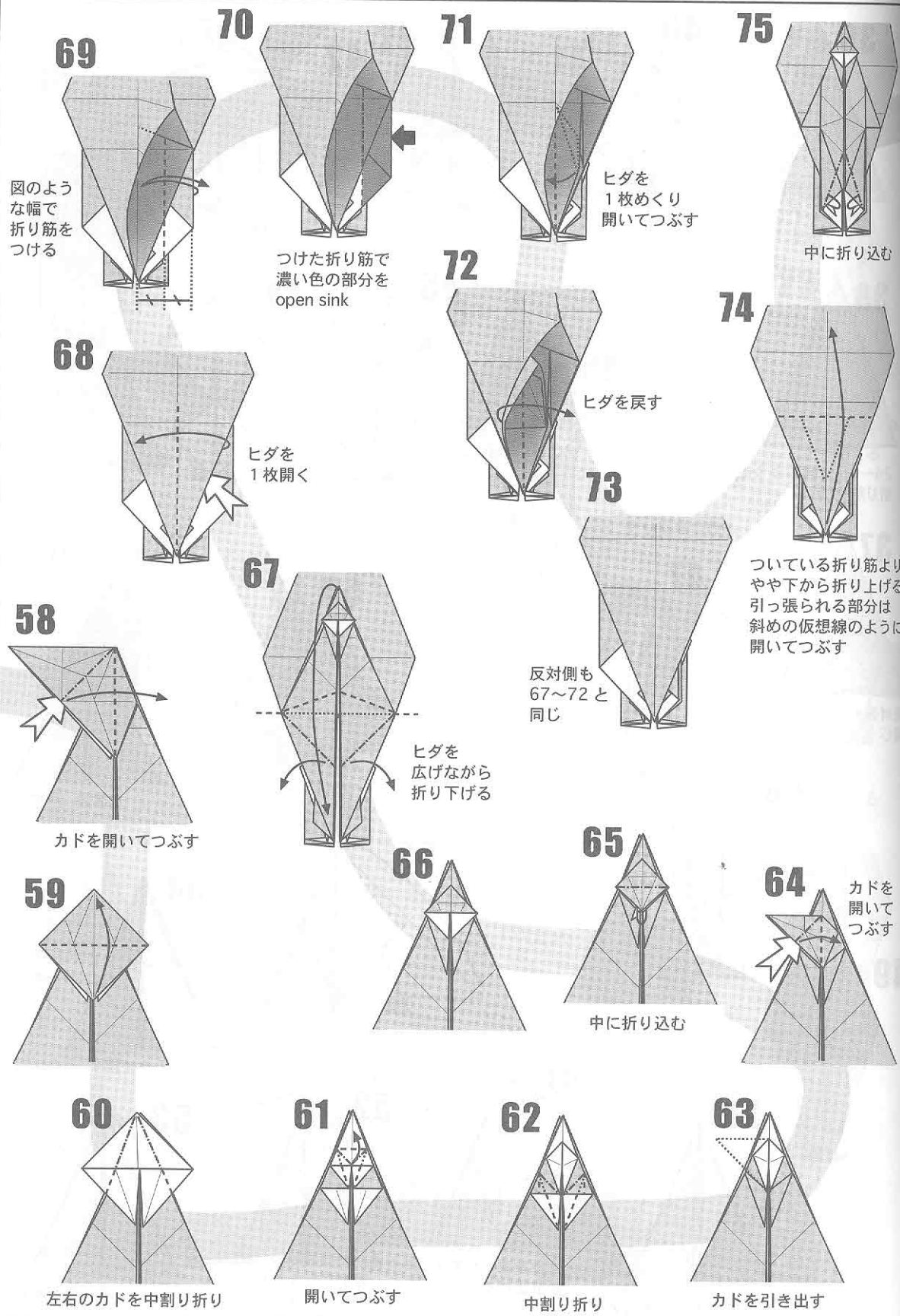

69

図のよう  
な幅で  
折り筋を  
つける

70

つけた折り筋で  
濃い色の部分を  
open sink

71

ヒダを  
1枚めくり  
開いてつぶす

75

中に折り込む

68

ヒダを  
1枚開く

72

ヒダを戻す

74

ついている折り筋より  
やや下から折り上げる  
引っ張られる部分は  
斜めの仮想線のように  
開いてつぶす

58

カドを開いてつぶす

67

ヒダを  
広げながら  
折り下げる

73

反対側も  
67~72と  
同じ

59

66

65

64

カドを  
開いて  
つぶす

中に折り込む

60

左右のカドを中割り折り

61

開いてつぶす

62

中割り折り

63

カドを引き出す

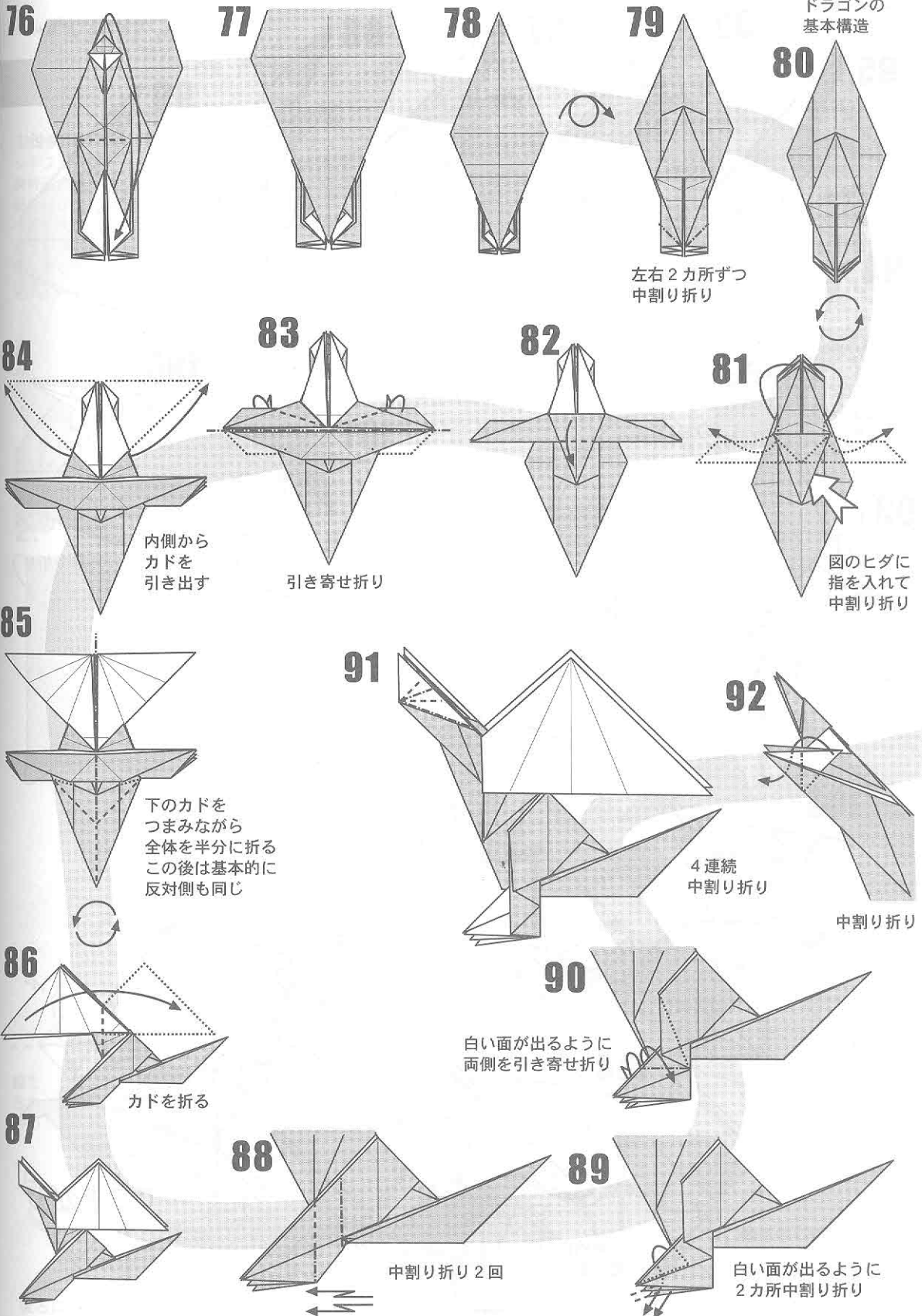

ドラゴンの基本構造

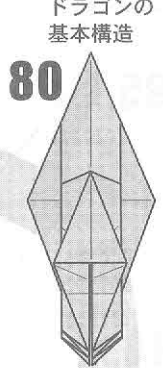
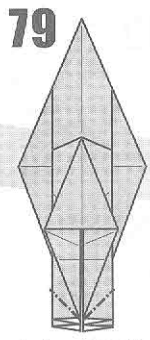
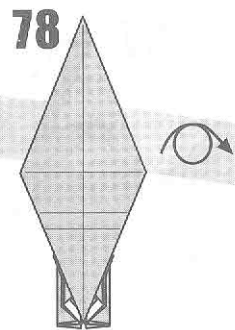
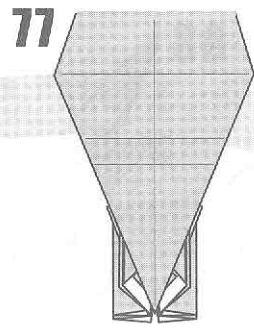
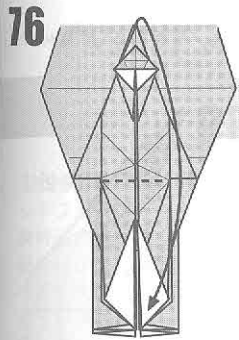

左右2カ所ずつ中割り折り

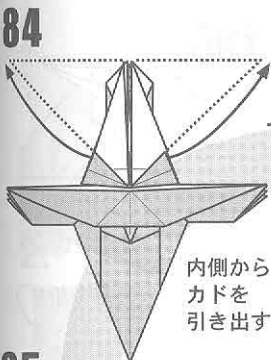

内側からカドを引き出す

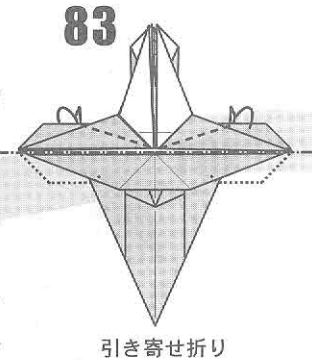

引き寄せ折り

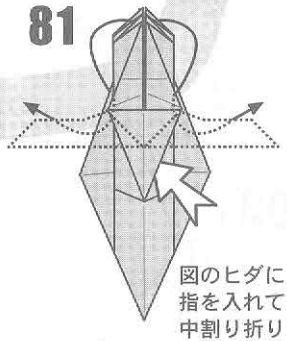
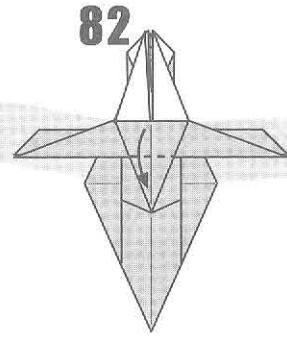

図のヒダに指を入れて中割り折り

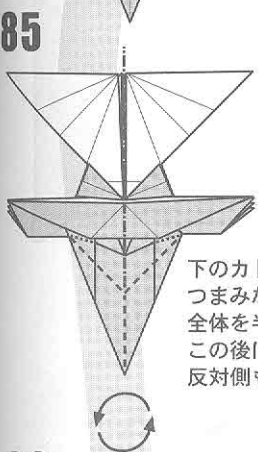

下のカドをつまみながら全体を半分に折るこの後は基本的に反対側も同じ

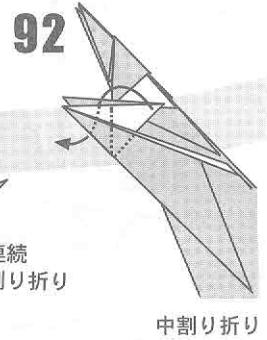
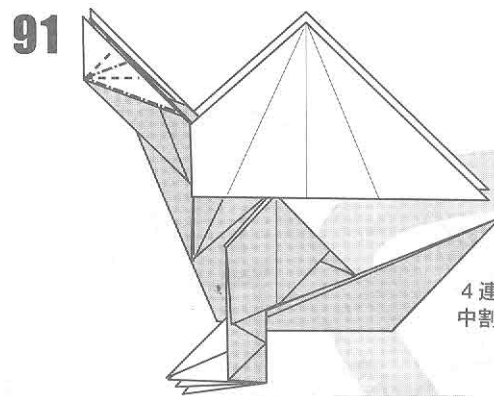

4連続中割り折り

中割り折り

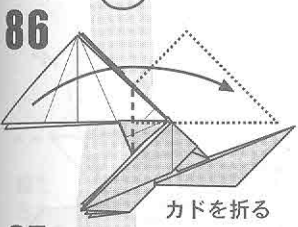

カドを折る

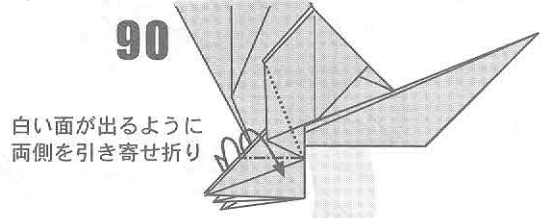

白い面が出るように両側を引き寄せ折り

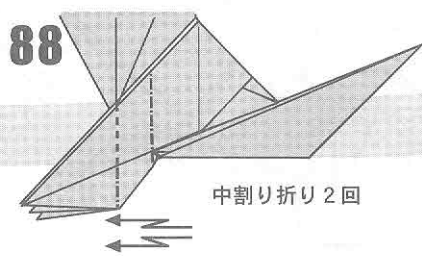
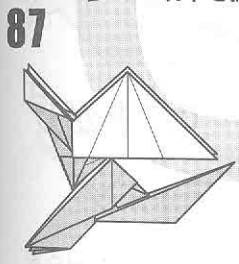

中割り折り2回

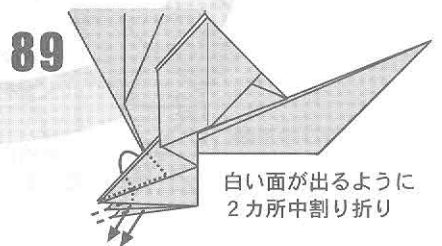

白い面が出るように2カ所中割り折り

95

カドを  
めくる

96

97

98

99

段折り

94

白い面が  
出るように  
3カ所  
かぶせ折り

白い面が  
出るように  
中割り折り

白い面が  
出るように  
中割り折り

折り下げる

100

中割り折り

93

2カ所  
中割り折り

101

102

段折り

103

かぶせ折り

105

104

立体的に  
形を整える

できあがり

# ～ペガサス～

By Kasumi

作/霞 誠志 2010年7月

このペガサスは、出来るだけ大きな紙を使ってウェットフォールディングでまとめるのがお勧めです。胸付近の紙の重なりが多く、とても分厚くなるので紙を破かないように気をつけてください。

ペガサスは当初、足に蹄があったのですが造形的にバランスが取れない(気がした?)ため、今回は省略しました。しかし、まだどこかで挑戦したいと思います。

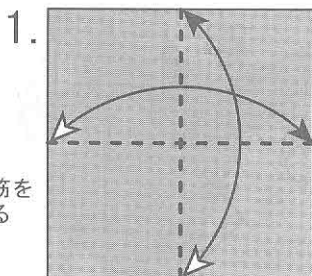
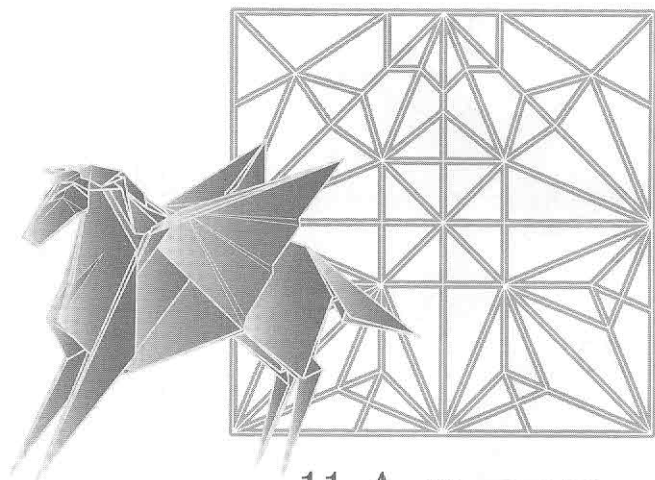

1. 折り筋を付ける

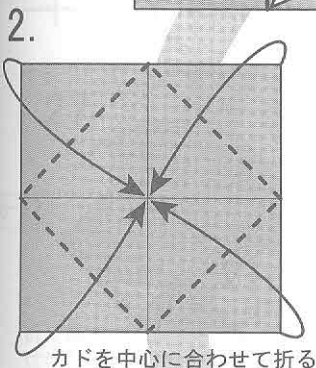

2. カドを中心に合わせて折る

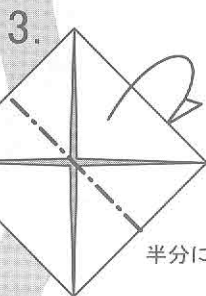

3.

半分に折る

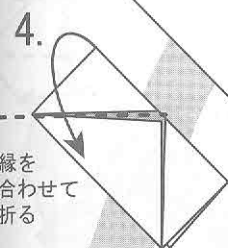

4. 縁を合わせて折る

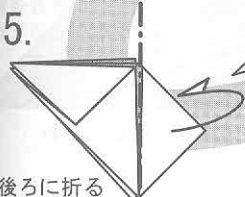

5. 後ろに折る

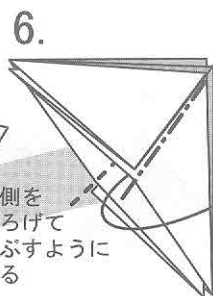

6. 内側をひろげてつぶすように折る

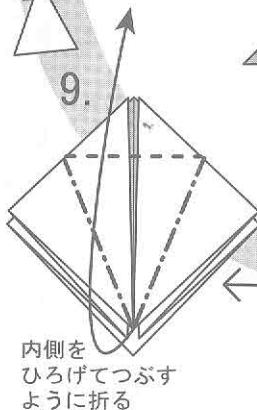

7. 内側をひろげてつぶすように折る

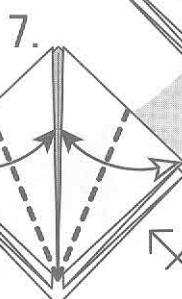

8. カドを反対側へ折る 反対側も同じ

9. 縁を中心線に合わせて折り筋をつける 反対側も同じ

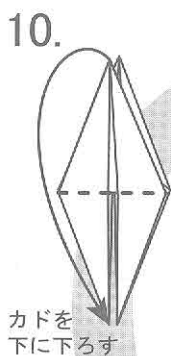

9. カドを下に下ろす

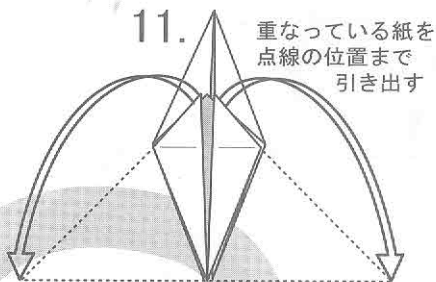

10. 重なっている紙を点線の位置まで引き出す

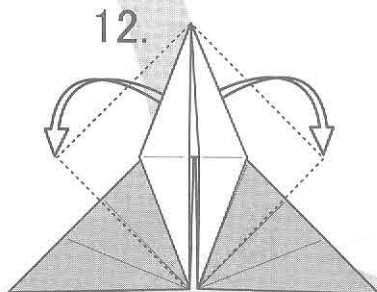

11. 重なっている紙を点線の位置まで引き出す

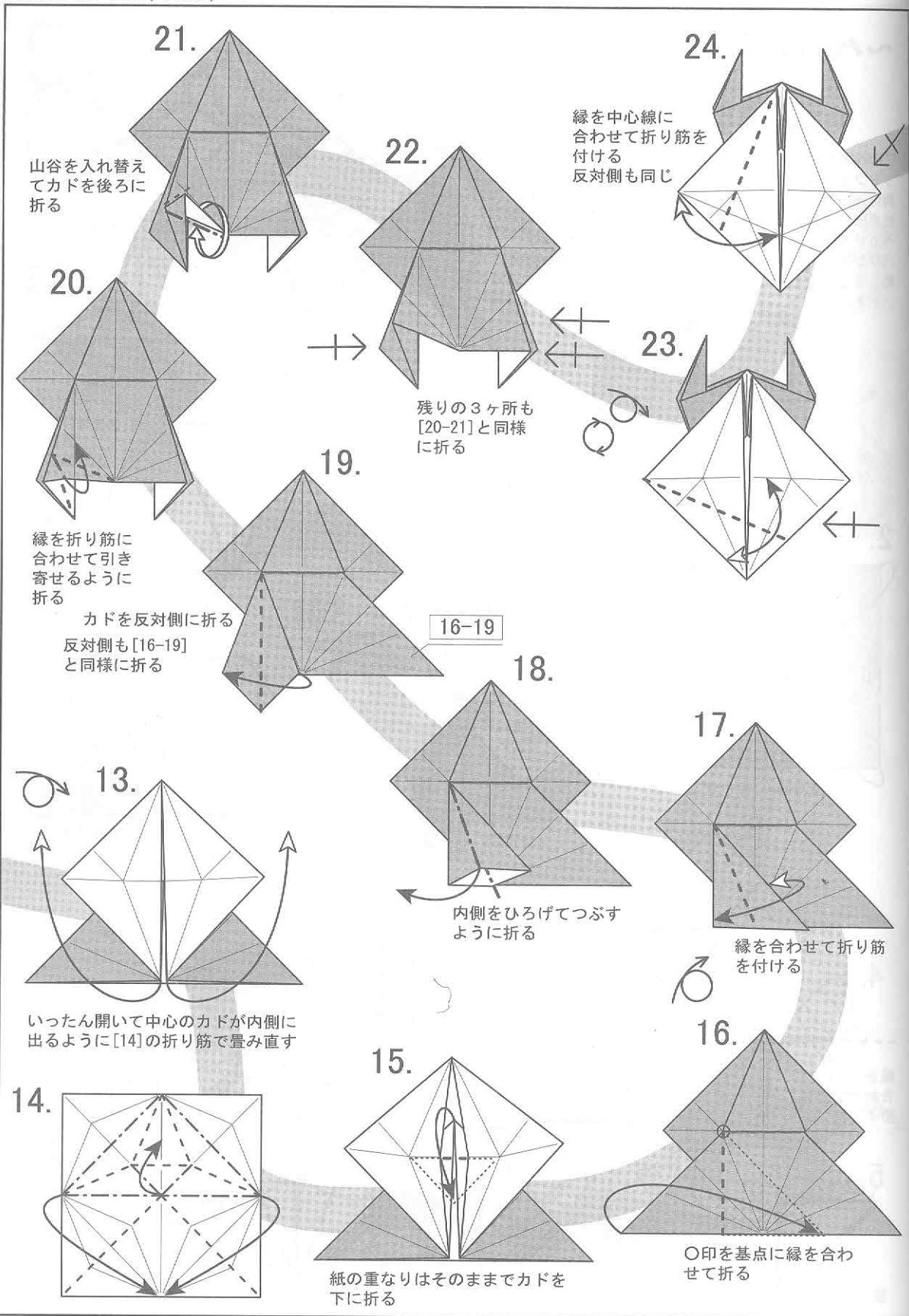

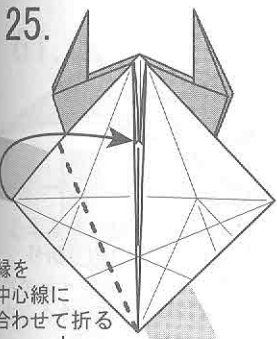

25.

縁を  
中心線に  
合わせて折る

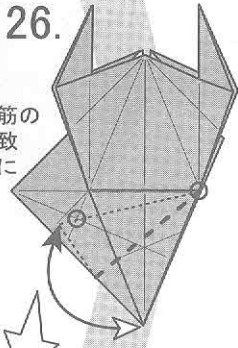

26.

縁が折り筋の  
交点と一致  
するように  
折る

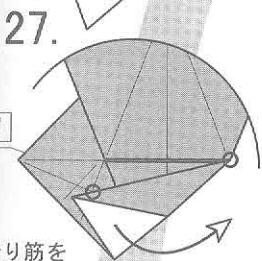

27.

25-27

折り筋を  
付けたら[25]の状態にに戻す  
反対側も[25-27]と同様に  
折り筋を付ける

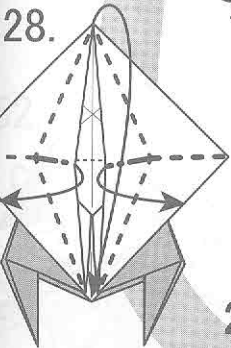

28.

縁を合わせて  
折りながら閉じる

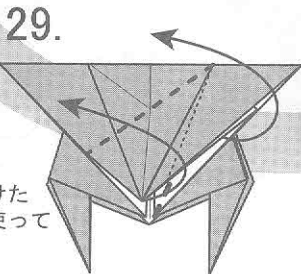

29.

[27]で付けた  
折り筋を使って  
折る

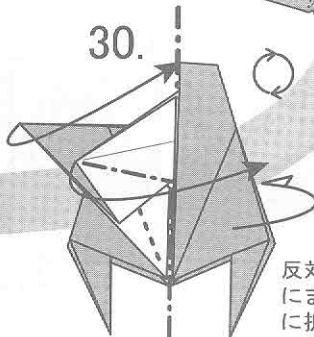

30.

ポケットの中で  
(紙の重なりはその  
ままで)カドを  
反対側へ折り返す  
反対側も同じ

反対側を[29]と同様に  
まとめながら半分  
に折る

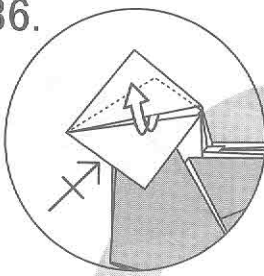

36.

重なっている  
内側のカドを  
引き出す  
反対側も同じ

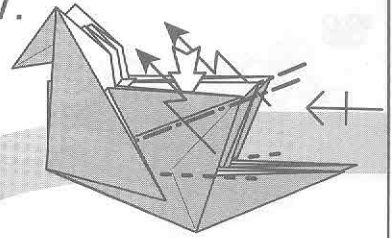

37.

両側で内側に段折り  
反対側も同じ

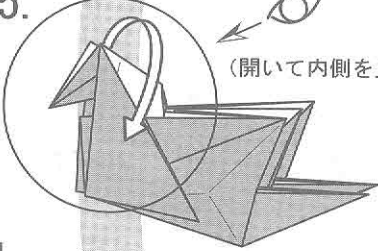

35.

(開いて内側を見る)

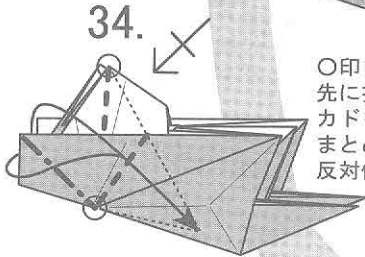

34.

○印を結ぶ線を  
先に折ってから  
カドをつまみ折りで  
まとめる  
反対側も同じ

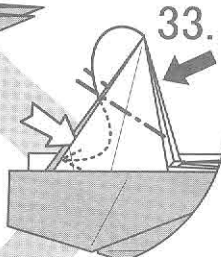

33.

中割折りで  
カドを  
中に入れる

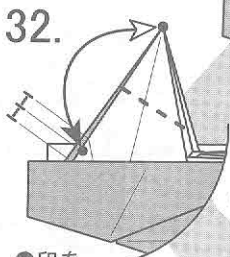

32.

●印を  
合わせて折り筋を  
付ける

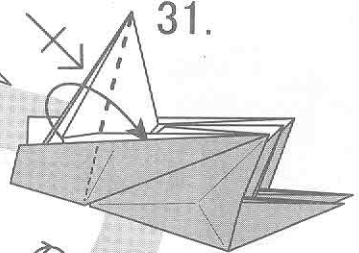

31.



38.

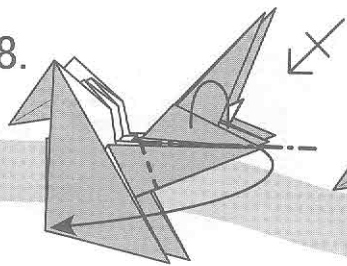

カドをいっばいの  
ところで反対側に  
折る  
反対側も同じ

39.

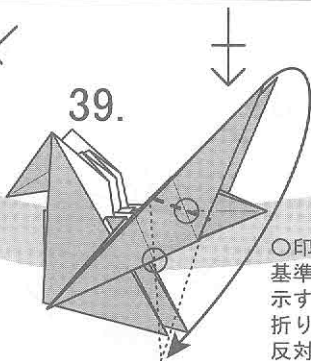

○印で示す位置を  
基準にして点線で  
示す位置に  
折り下げる  
反対側も同じ

40.

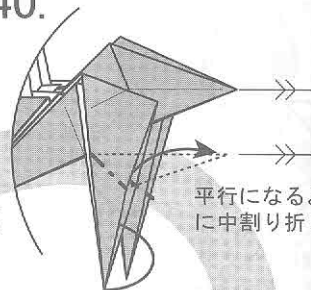

平行になるよう  
に中割り折り

43.

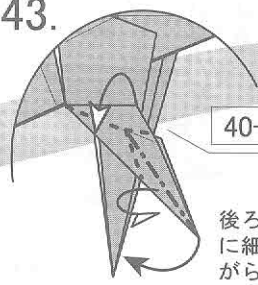

後ろ足を半分  
に細く折りなが  
ら閉じる  
反対側も  
[40-43]と  
同様に折る

42.

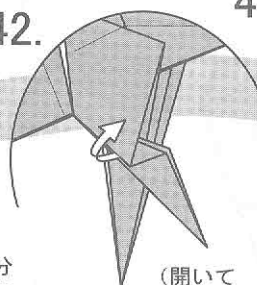

(開いて  
内側を見る)

41.

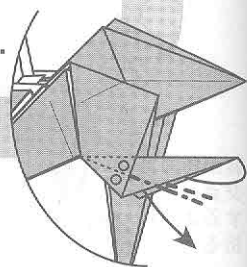

中割り折り

44.

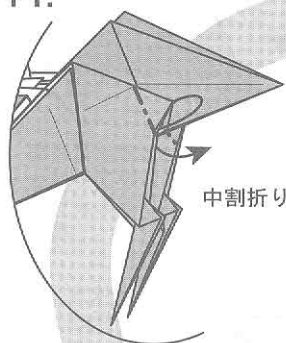

中割り折り

45.

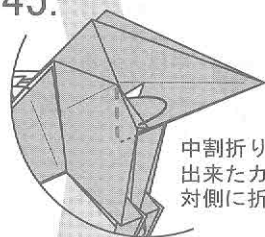

中割り折りで  
出来たカドを反  
対側に折る

(上の一枚だけを)  
縁を合わせて折りな  
がら全体を閉じる

49.

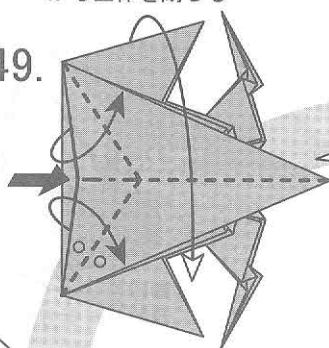

カドをすぐ  
後ろに折る

50.

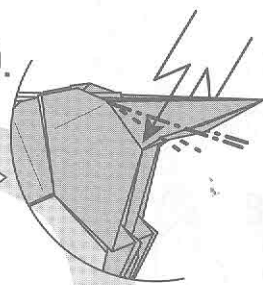

両側で段折り

46.

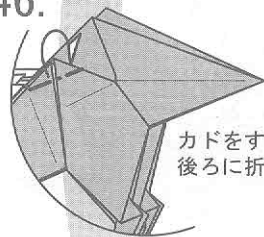

51.

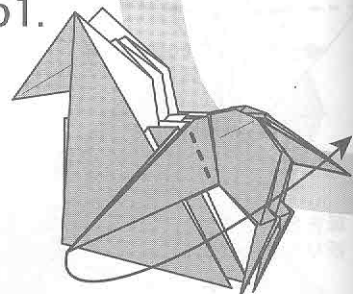

カドを反対側に折る

47.

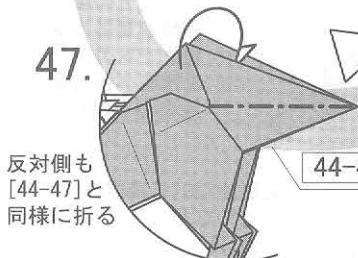

反対側も  
[44-47]と  
同様に折る

44-47

48.

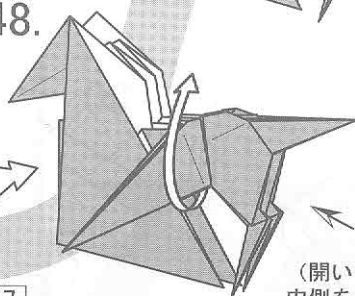

カドをすぐ後ろの  
ポケットに入れる  
ように折る

(開いて  
内側を見る)

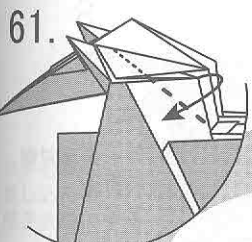

61. ポケットの奥の引っかかる  
ところから折り返す

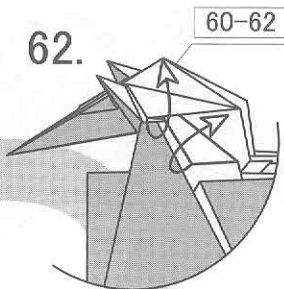

62. 60-62  
反対側も[60-62]と  
同様に折り筋を  
付ける  
しっかりと折筋を  
付けたら[60]の  
状態に戻す

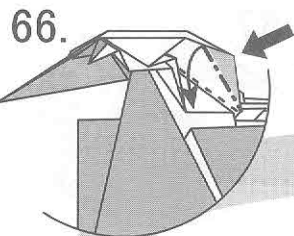

66. 濃い色の部分を  
ひろげてつぶす  
ように折る

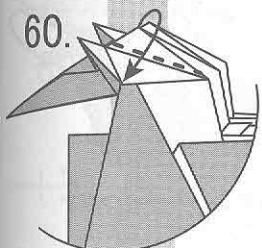

60. 次のカドも手前と同じ  
位置で折る

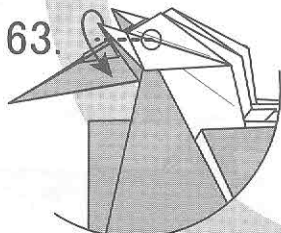

63. ○印を基点に耳を  
下へ折る

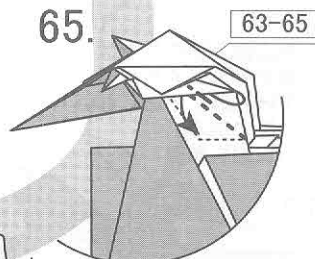

65. 63-65  
[61]で付けた  
折り筋を使って  
段折りのような  
中割折り  
反対側も[63-65]と  
同様に折る

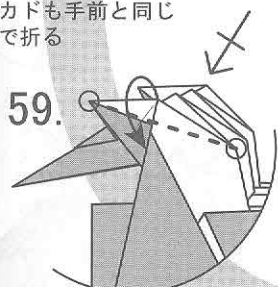

59. ○印を結ぶ線で折る  
反対側も同じ

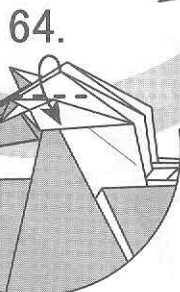

64. 手前と同じ位置で折る

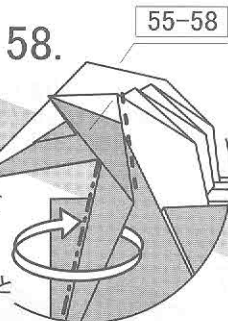

58. 55-58  
山谷を入れ替えて  
すぐ後ろの隙間  
に入れる  
反対側も[55-58]と  
同様に折る

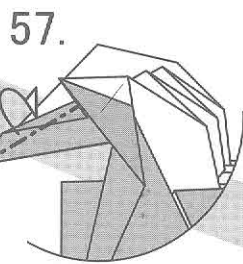

57. カドをすぐ後ろに折る

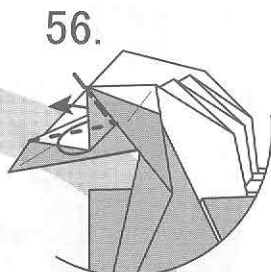

56. もう一度中割折り

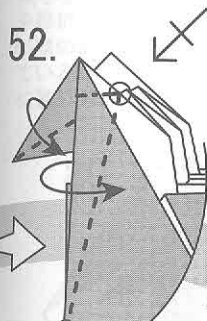

52. ○印を  
結ぶ線で引き寄せる  
ように折る  
反対側も同じ

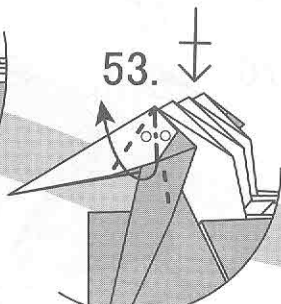

53. ○印部分をつまんで  
引き上げる  
反対側も同じ

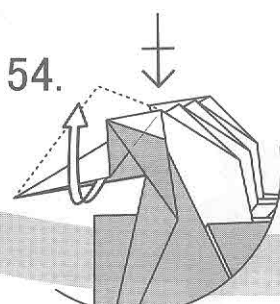

54. いっぱいのところ  
まで紙を引き出す  
反対側も同じ

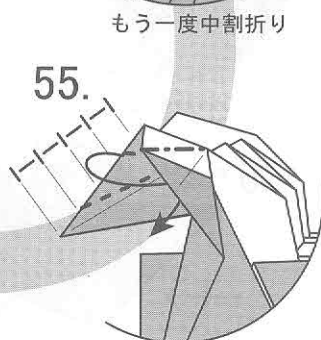

55. 中割折り  
(位置に注意)

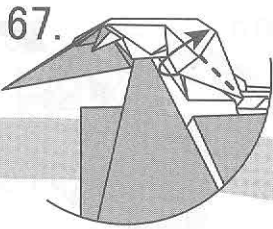

67. 平らにつぶしたらカドを戻す

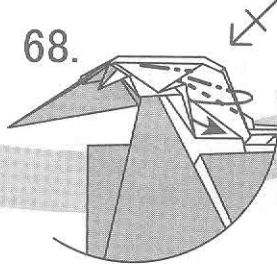

68. 段折りのような中割り折り 反対側も同じ

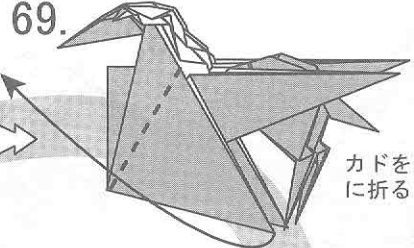

69. カドを反対側に折る

※山折り線の位置は、前足のカドを折り下げた時に干渉しない位置で折る (次図を参照)

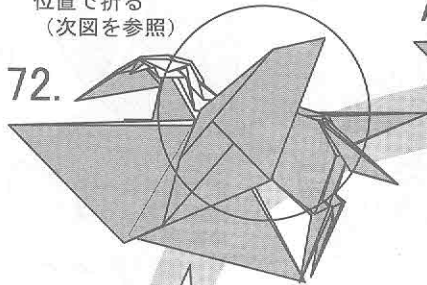

72.

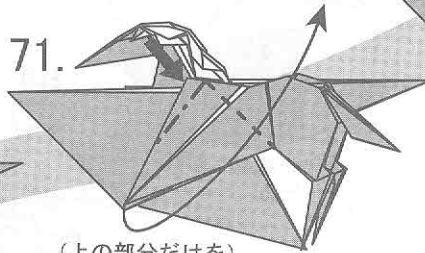

71.

(上の部分だけを) 内側をひろげてつぶすように折る

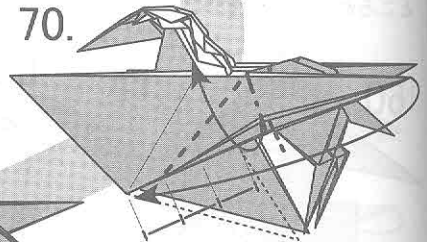

70.

内側をひろげてつぶすように折る

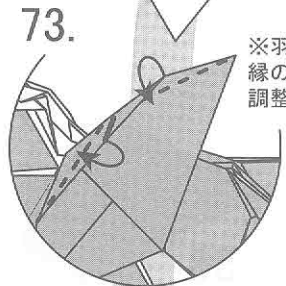

73.

※羽の段折りの後で縁の部分の位置を調整する

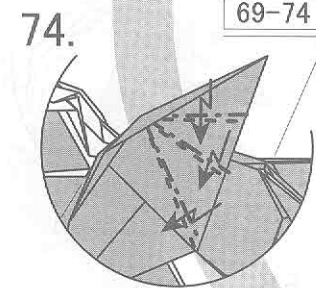

74.

69-74

羽の部分を段折り

反対側も [69-74] と同様に折る

中割り折り ※山折り線の位置はカドの角度の1/3ぐらいで折る

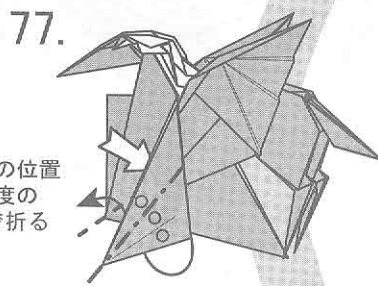

77.

76.

ここは少し隙間が空く

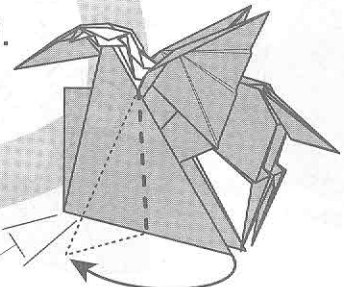

カドを点線で示す位置へ折る

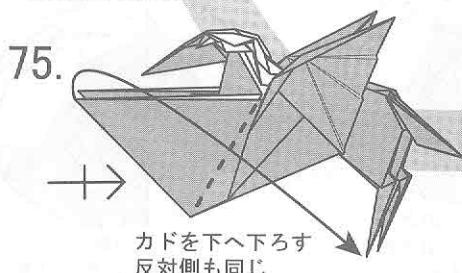

75.

カドを下へ下ろす 反対側も同じ

もう一度中割り折り 反対側も [76-78] と同様に折る

76-78

88.

カドを隙間に  
差し込んで  
開き止めにする

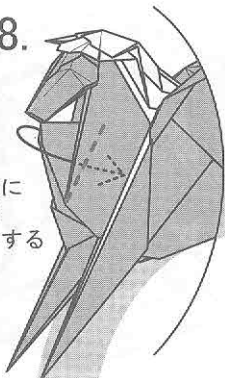

87.

[49]で折ってできた  
内側にあるカドを  
隙間に差し込んで  
開き止めにする

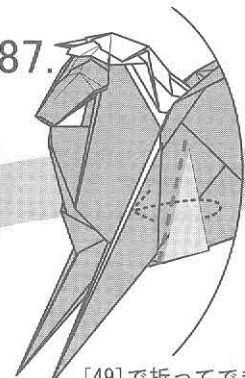

86.

反対側も [84-86]  
と同様に折る

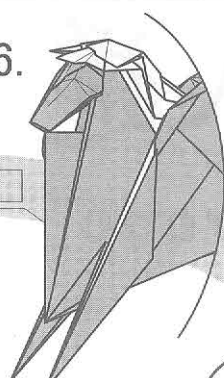

85.

引き寄せるよう  
に折る

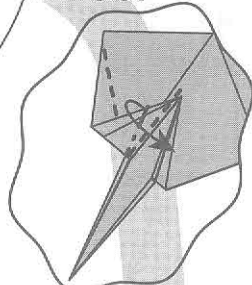

89.



胸の部分を段折り  
タテガミの部分を  
少し開いて形を  
調整する  
反対側も同じ

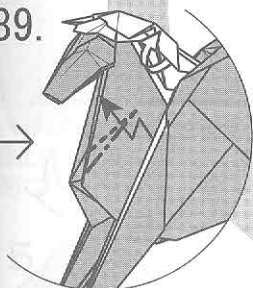

90.

完成

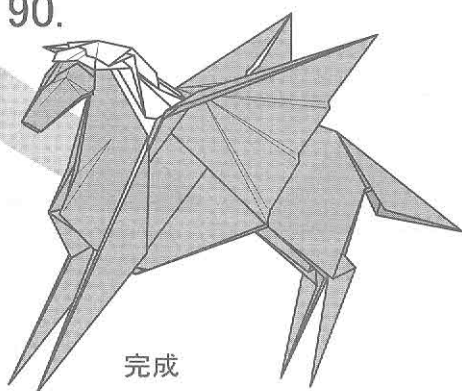

84.

前足の部分を  
透視

いっぱいのところまで  
カドを上へ折る  
(次の図を参照)

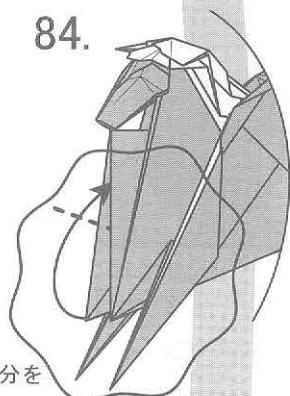

79.

紙の重なりをそのまま  
保ちながら、頭の部分  
を段折りで下に向ける  
(頭の部分が3層になっ  
ているので、1枚と2枚  
に振り分ける)

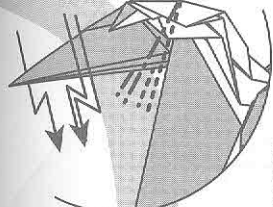

※注意  
説明の為、不要なカドは  
描画していません

83.

段折りと山折りを  
加えて顔を立体化  
する  
反対側も同じ

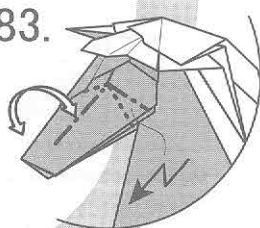

80.

中割折りでカドを  
中に入れる

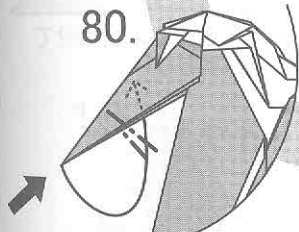

81.

耳を立てながら  
円錐形に膨らませ  
て立体化する  
反対側も同じ

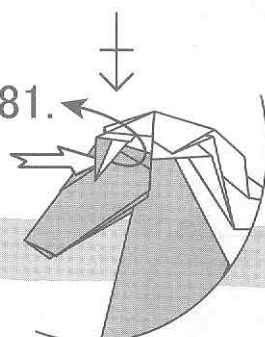

82.

目の部分を段折り  
反対側も同じ

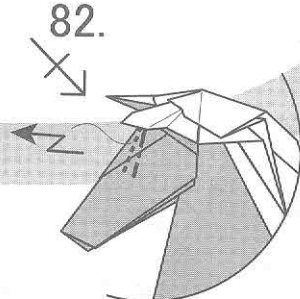

# 輪入道

## Wanyudo

創作および作図 尾川 知

創作 2010年

作図 2013年6月

Model & Diagrams

by Ogawa Tomo

Designed: 2010

Diagramed: 2013/6

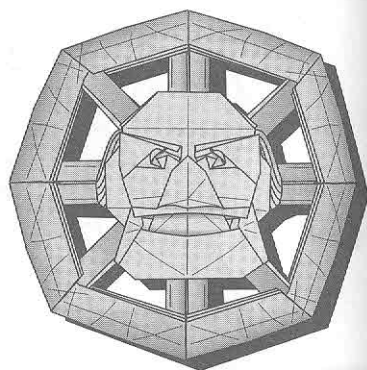

1

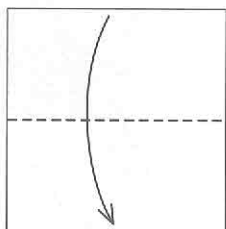

半分に折る

2

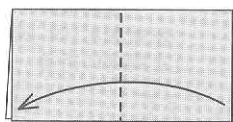

半分に折る

3

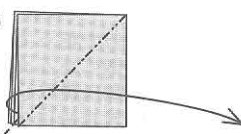

内側をひろげて  
たたむように折る

4

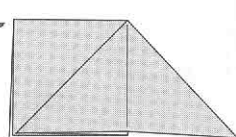

裏側も同様に折る

7

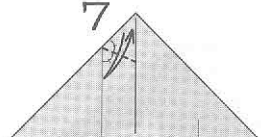

フチを折り目に合わせて  
折り目をつける

6

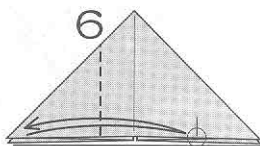

カドを○に合わせて  
折り目をつける

5

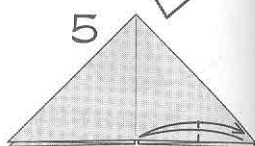

カドを中心に合わせて  
折り目をつける

8

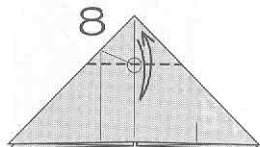

○をとる線で  
折り目をつける

9

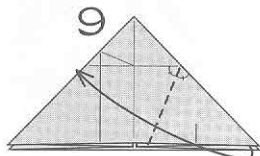

フチを折り目に合わせて折る

10

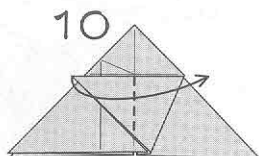

中心の線に合わせて折る

11

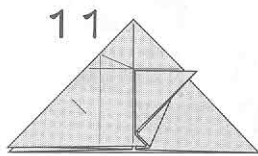

8のかたちまでもどす  
(以下、必要な折り目  
のみを表示する)

12

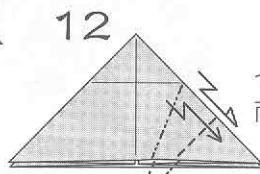

ついている折り目で  
両側に段折り

13

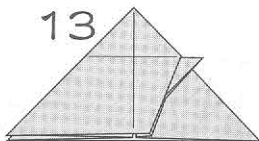

左側も9-12と同様に折る

14

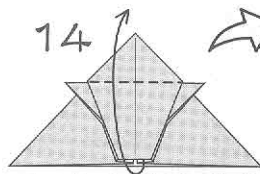

ついている折り目で折る

15

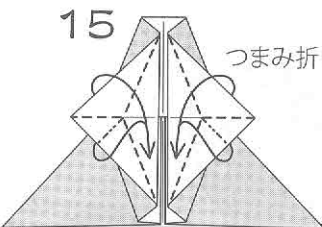

つまみ折り

16

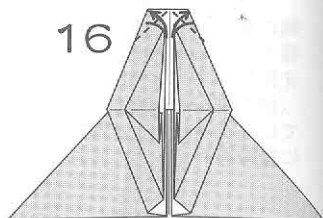

フチを中心に合わせて  
折り目をつける

17

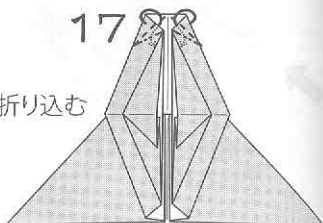

内側に折り込む

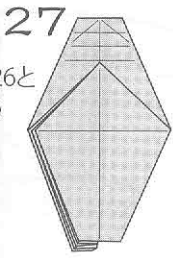

裏側も25-26と同様に折る

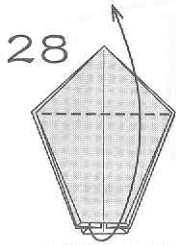

カドを上折る  
裏側も同様に折る

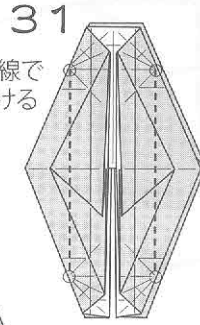

○をむすぶ線で  
折り目をつける

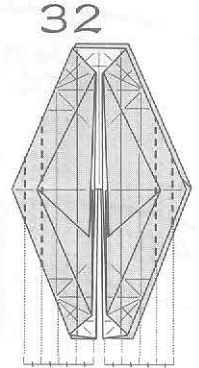

つけた折り目と  
等しい幅で  
折り目をつける

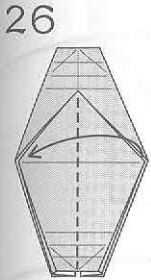

一番上のカドを  
左側に折る

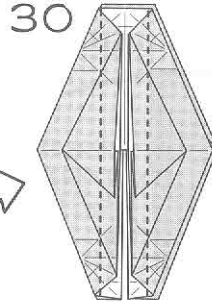

すでについている  
折り目を延長して  
折り目をつける

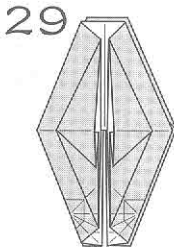

16-23と同様に折る  
裏側も同様に折る

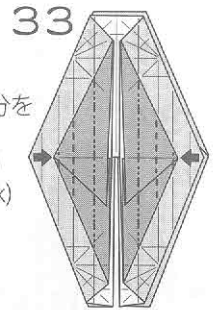

■の部分  
連続して  
しずめ折り  
(Open sink)

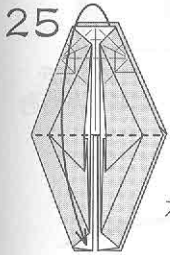

カドを下に折る

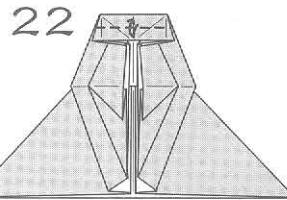

フチとフチを  
合わせて  
折り目をつける

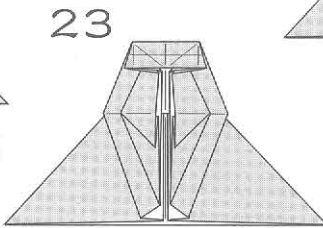

16のかたちまでもどす

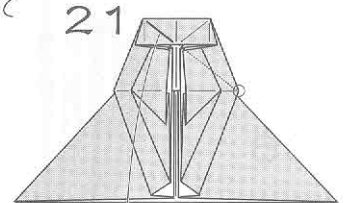

正確に折れていれば  
太く示した折り目の  
延長線上に○がある

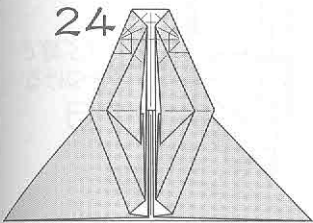

裏側も9-23と同様に折る

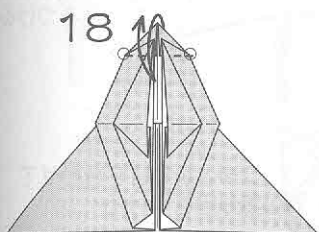

○をむすぶ線で折り目をつける

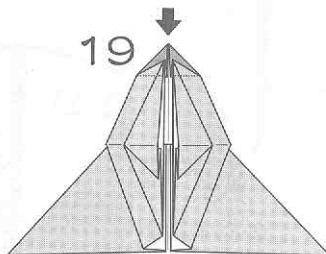

■の部分  
を押し込む

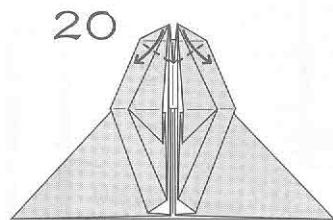

2つのカドを折って下げる

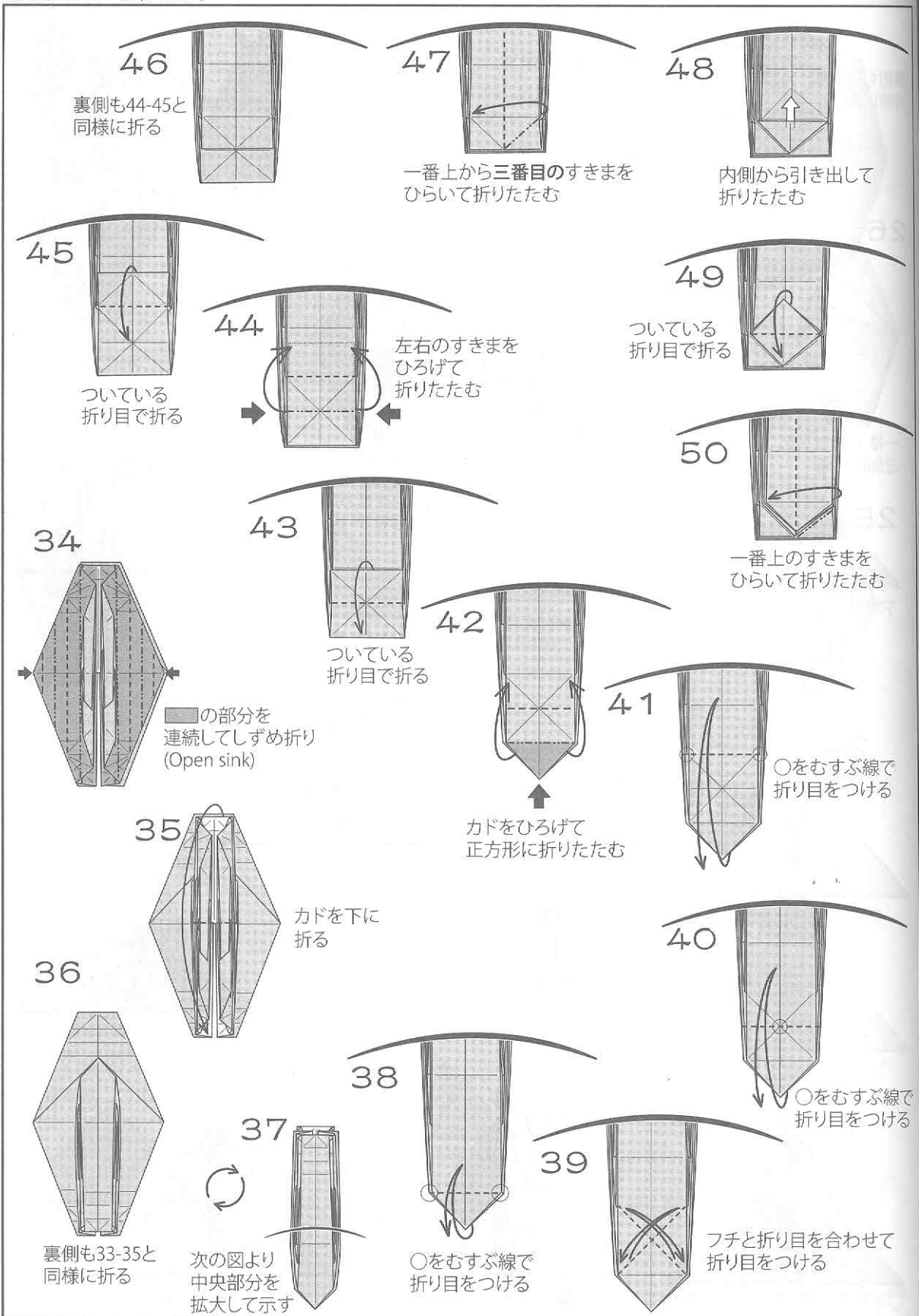

54

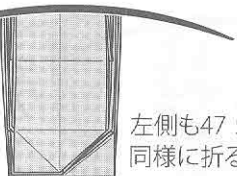

左側も47 53と  
同様に折る

55

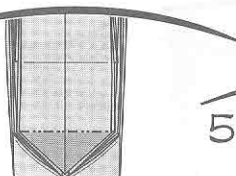

しずめ折り  
(Open sink)

56

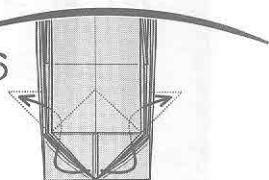

一番上のすきまで中わり折り

53

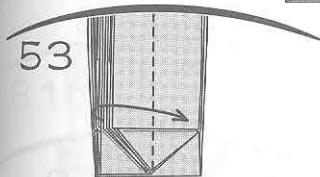

一番上から四番目の  
すきまをひろげる

52

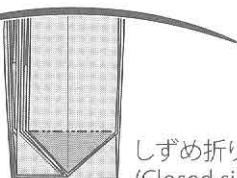

しずめ折り  
(Closed sink)

57

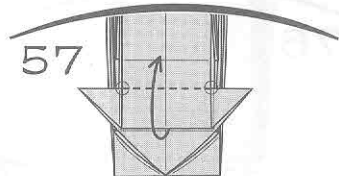

○を結ぶ線で折る

51

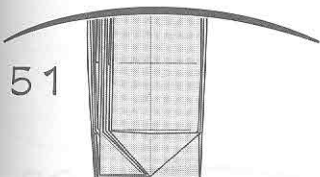

48-49と同様に折る

58

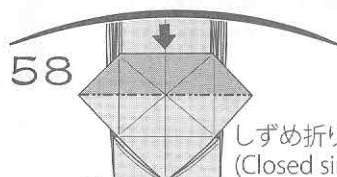

しずめ折り  
(Closed sink)

60

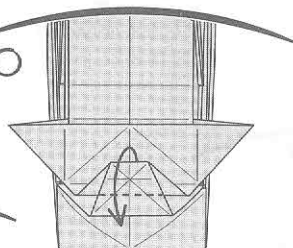

折れるいっぱいまで折る

59

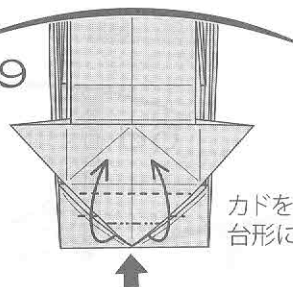

カドをひろげて  
台形に折りたたむ

61

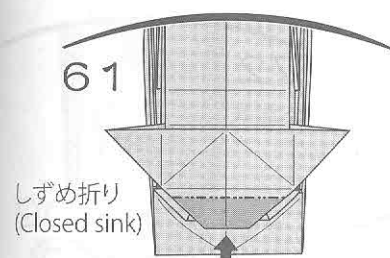

しずめ折り  
(Closed sink)

62

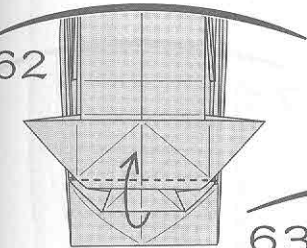

ついている  
折り目で折る

63

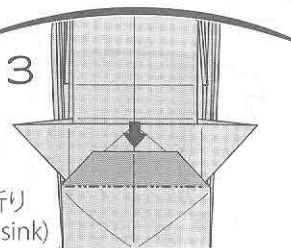

しずめ折り  
(Closed sink)

64

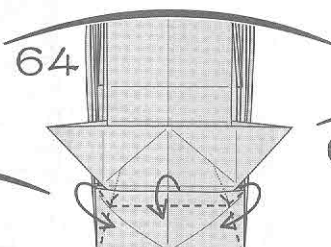

中央のフチを下に折り  
両側を引き寄せて  
折りたたむ

65

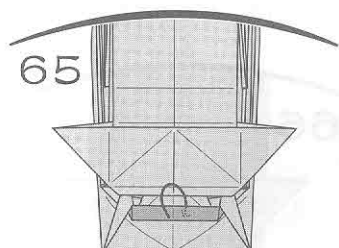

■の部分  
内側に折り込む



77

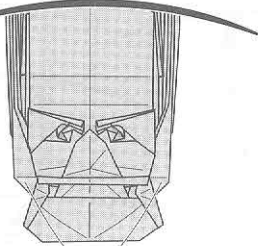

このカドが残る

78

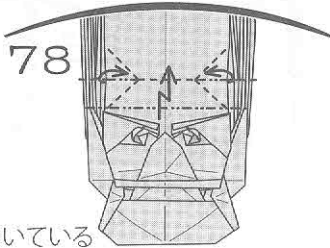

ついている  
折り目で段折りしながら、  
左右のヒダを一枚ずつ  
折りたたむ

79

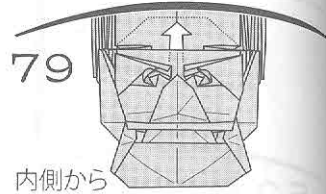

内側から  
引き出してたたむ

76

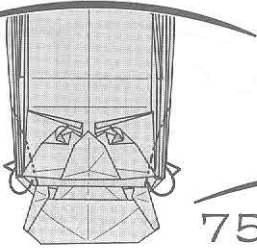

一番の下のカドを残して  
折り込む

75

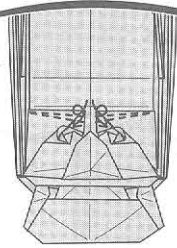

巻くように折って  
眉を表現する

74

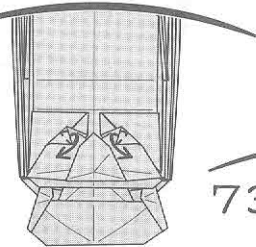

すきまをひろげて  
立体的に折る

80

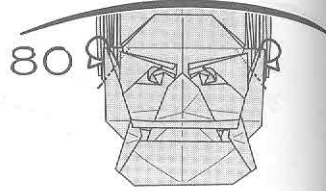

カドを折り込む

73

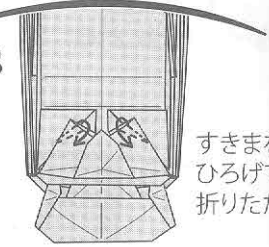

すきまを  
ひろげて  
折りたたむ

68

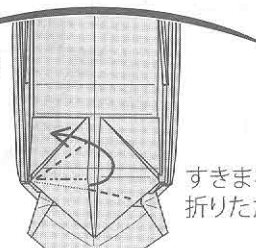

すきまをひろげて  
折りたたむ

72

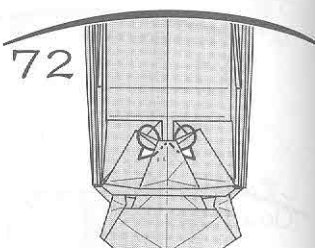

カドを折り込む

67

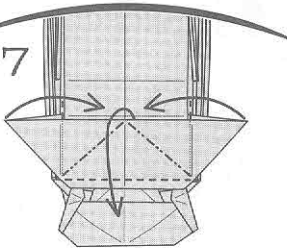

中央のフチを下に折り  
両側のカドを中央に  
引きよせて折りたたむ

69

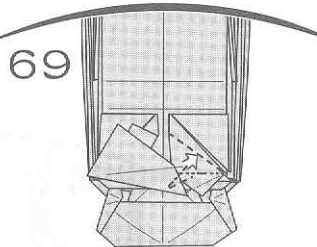

内側から引き出して  
折りたたむ

71

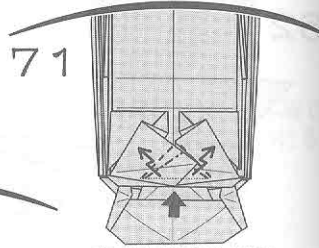

すきまをひろげて  
折りたたむ

66

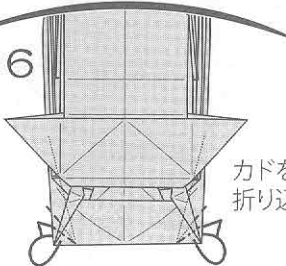

カドを引きよせながら  
折り込む

70

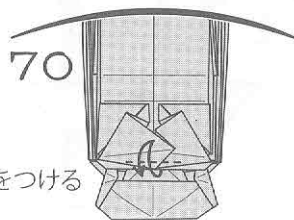

折り目をつける

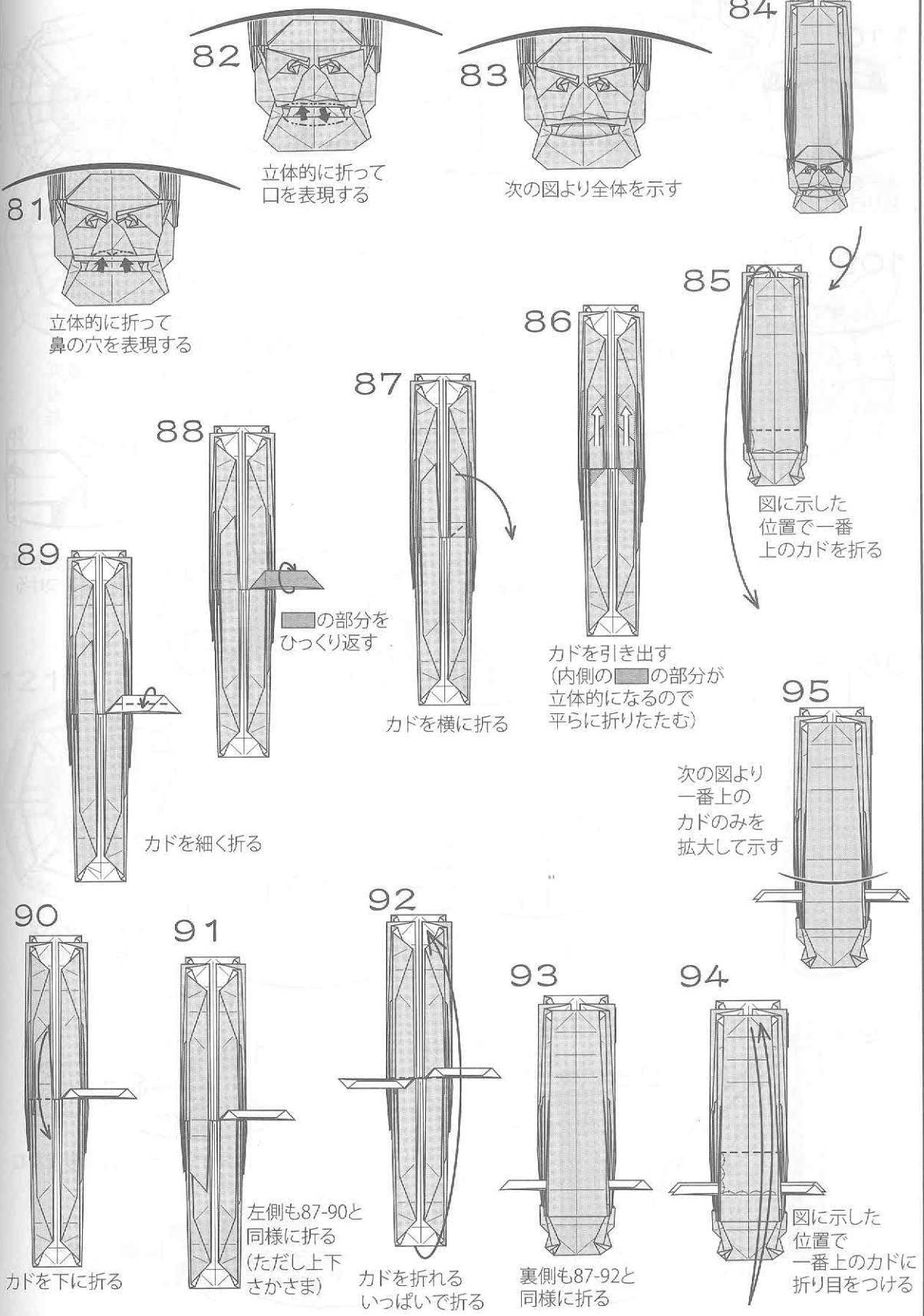

82

立体的に折って  
口を表現する

83

次の図より全体を示す

84

81

立体的に折って  
鼻の穴を表現する

85

図に示した  
位置で一番  
上のカドを折る

86

カドを引き出す  
(内側の■の部分  
が立体的になるので  
平らに折りたたむ)

87

カドを横に折る

88

■の部分  
をひっくり返す

95

次の図より  
一番上の  
カドのみを  
拡大して示す

89

カドを細く折る

90

カドを下に折る

91

左側も87-90と  
同様に折る  
(ただし上下  
さかさま)

92

カドを折れる  
いっぱい折る

93

裏側も87-92と  
同様に折る

94

図に示した  
位置で  
一番上のカドに  
折り目をつける

110

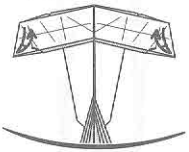

カドをフチに合わせて  
折り目をつける

111

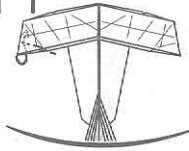

中割り折り

112

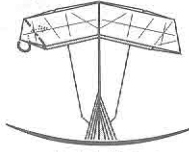

中割り折り

113

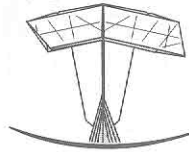

ほかの三つのカドも  
96-112と同様に折る  
次の図より全体を示す

114

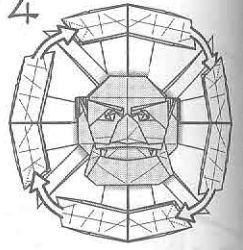

カドをすきまに差し込む

109



カドをひろげる  
次の図より見る  
角度を変える

108



カドを折る

107

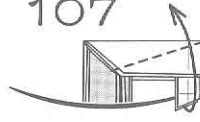

一番上のカドを折る  
裏側も同様に折る

106

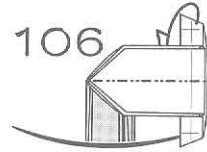

半分に折る

105

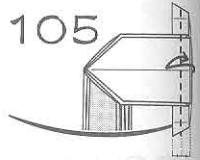

図に示した位置で  
折り目をつける

96

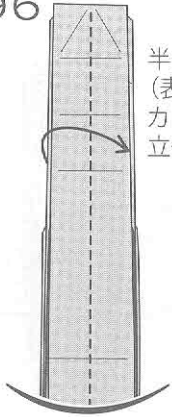

半分に折る  
(表示されていない  
カドのつけねの部分は  
立体的になる)

103

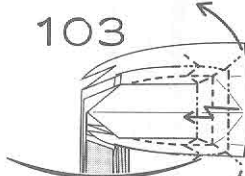

引きつづき  
ついている折り目をもとに  
折りたたむ

104

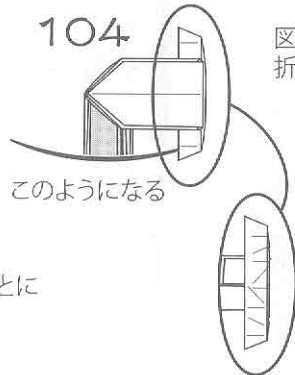

このようになる

裏からみたところ

102

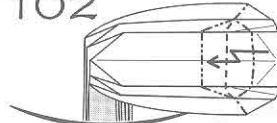

ついている折り目をもとに  
折りたたむ

101

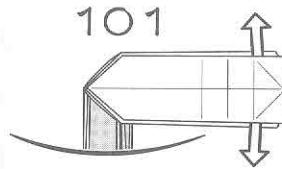

段折りされている  
部分をひろげる

97

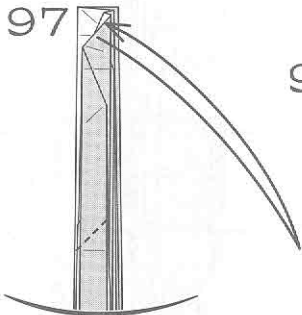

フチを折り目に合わせて  
折り目をつける

98

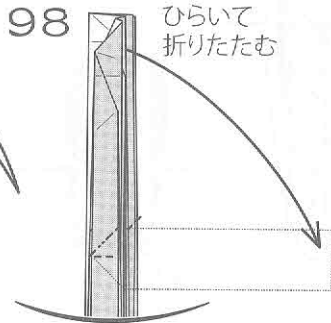

ヒダを真ん中で  
ひらいて  
折りたたむ

100

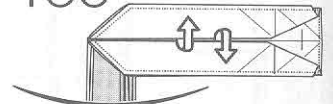

内側から引き出して折りたたむ

99

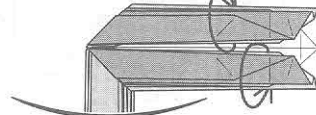

の部分を  
ひっくり返す

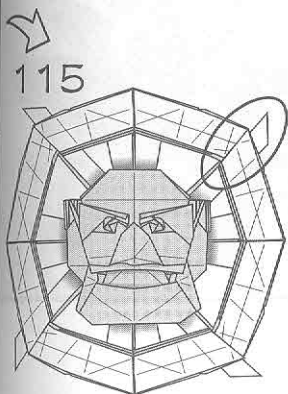

115

次の図より差し込んだ部分を透視して示す

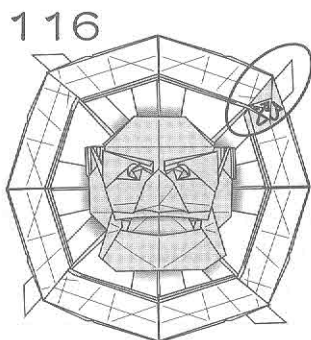

116

差し込んだカドを110でつけた折り目でかぶせ折りする

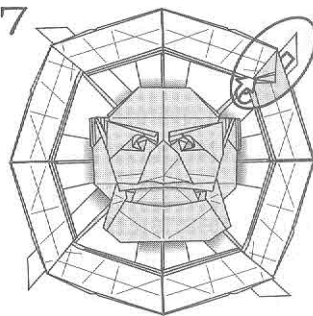

117

カドをすきまに差し込む

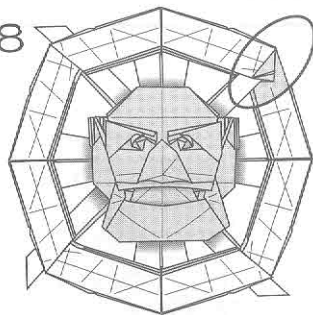

118

ほかの三カ所も116-117と同様に折る  
次の図より透視しないで示す

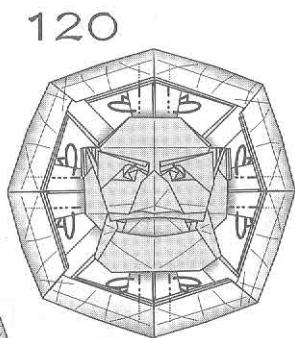

120

折り込んで輻(スポーク)を細くする  
(輪との接続部分は立体的に折る)

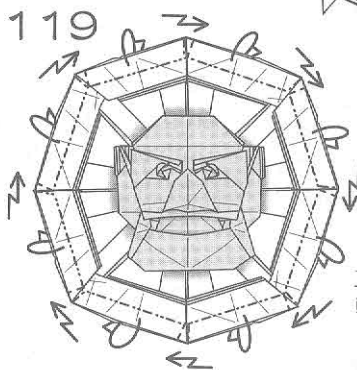

119

立体的に折って輪を細くする

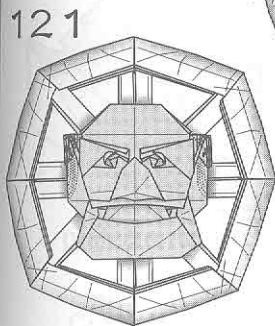

121

ヒダを連続して折り髪を表現する

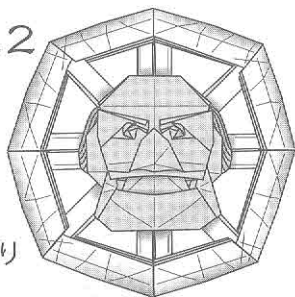

122

できあがり

114-118でカドとカドをつないだ部分はずれやすいため、使う紙の大きさ・紙質に合わせた方法で固定するとよいでしょう

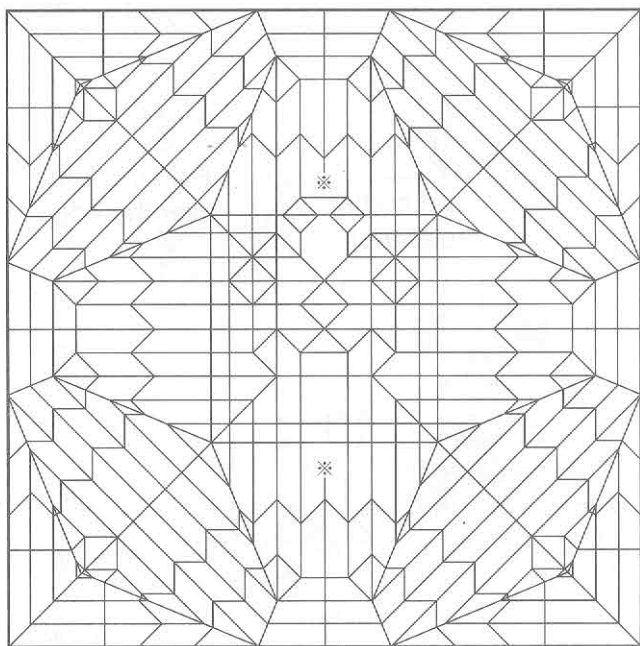

展開図

※の部分は平らにならない

# Laços do Infinito ©2011

Created by: Isa Klein (Minas Gerais, Brasil)  
Diagram by: Marcio Noguchi (New York, USA)

“Laços do Infinito” means Loops of Infinite in Portuguese. This model works best with double sided paper. Using 30 sheets of 7.5 cm x 7.5 cm results in a model of about 12.5 cm of diameter. Several variations are possible.

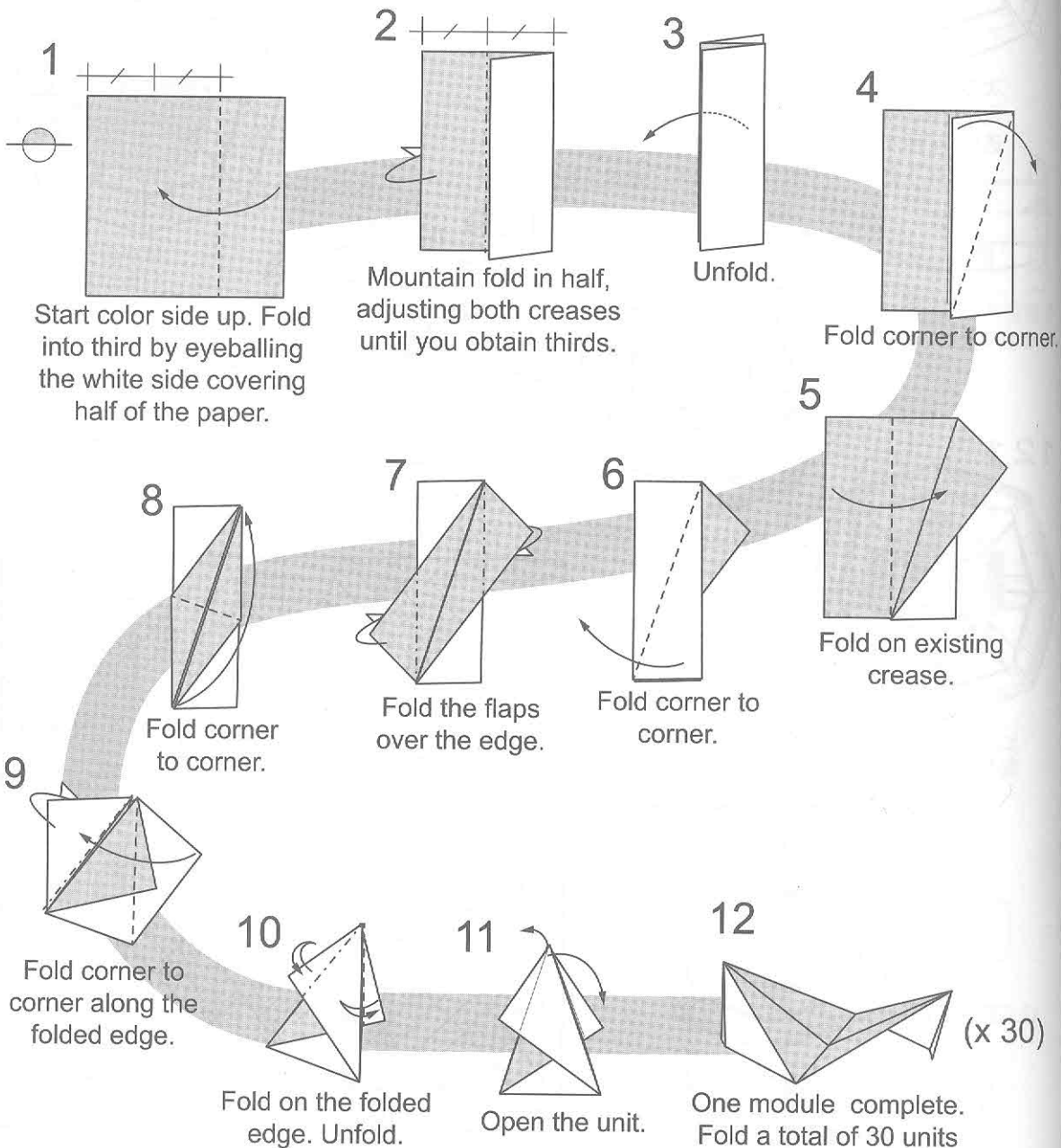
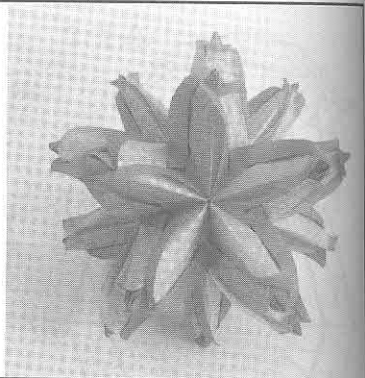

# Assembly

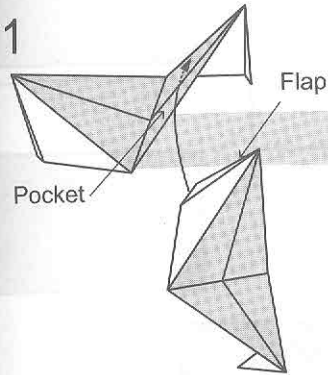

Insert the flap of the second unit into the pocket of the first one.

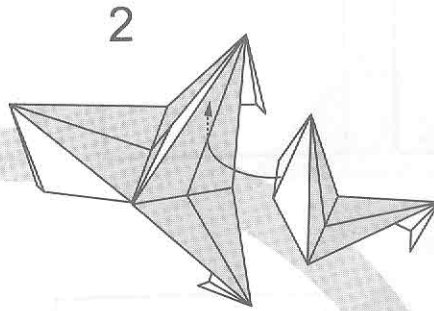

Insert the flap of the third unit into the pocket of the second one.

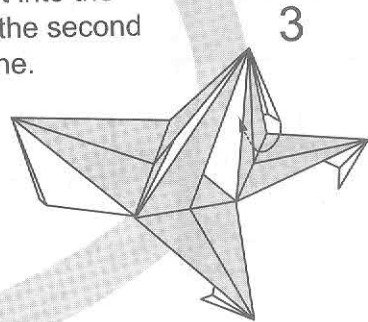

Insert the flap of the first unit into the pocket of the third one, completing a pyramid.

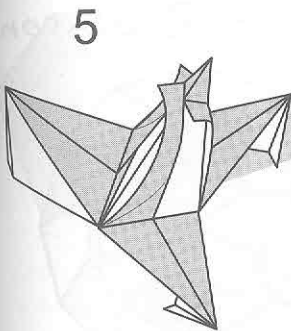

"Peel" the top layer only, on all sides.

Continue assembling the units to form a ring of five pyramids. Assemble all the rest of units in the similar way.

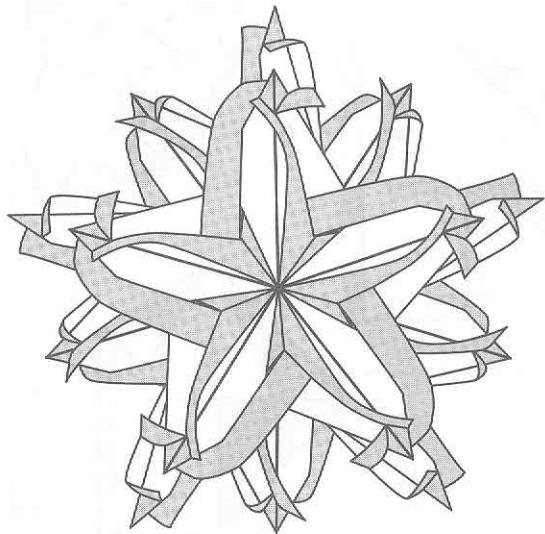

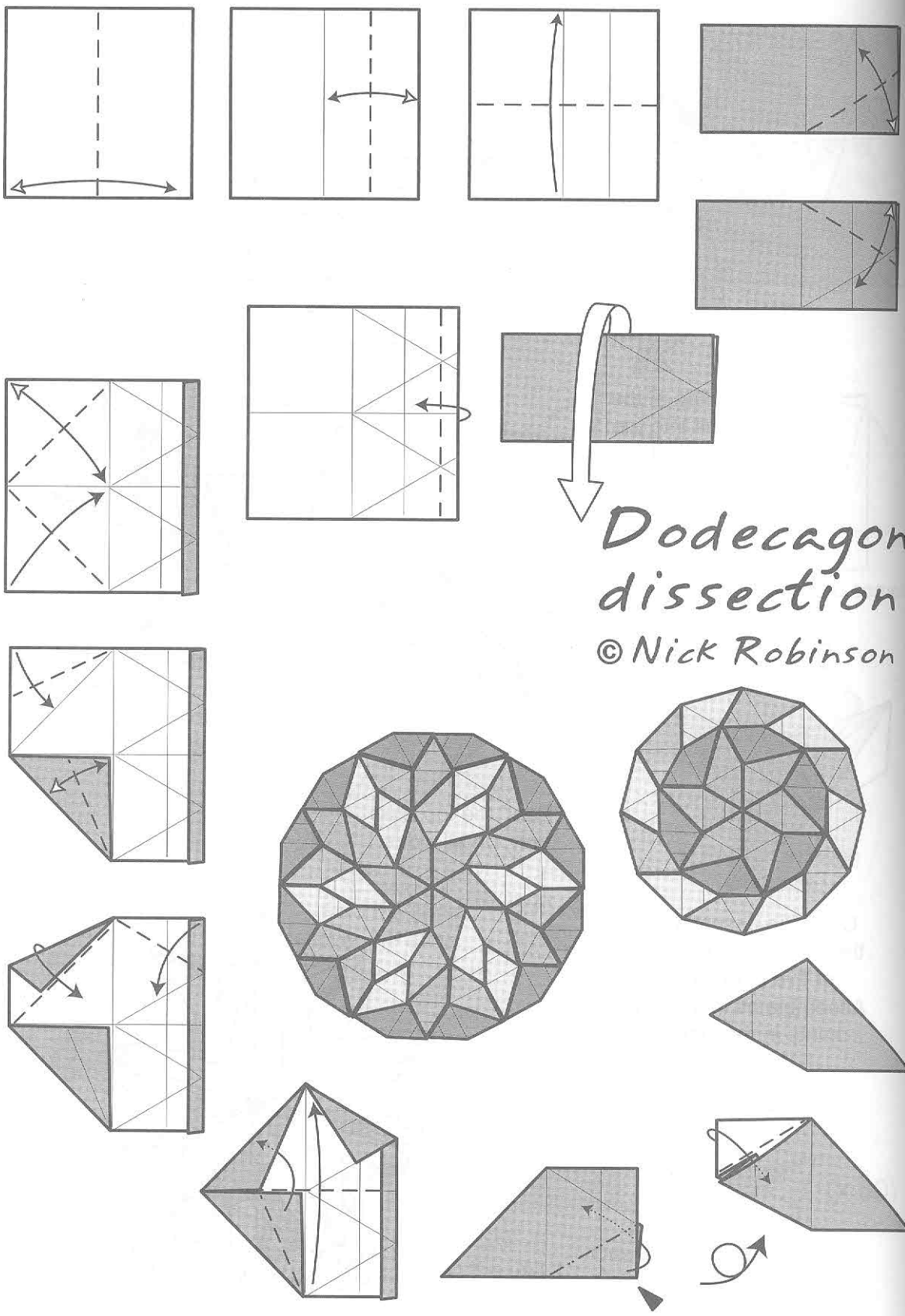

*Dodecagon  
dissection*  
© Nick Robinson

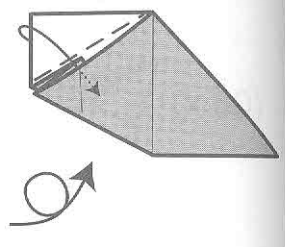
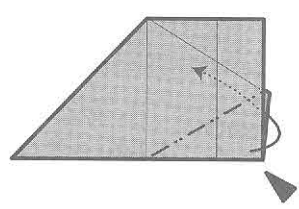
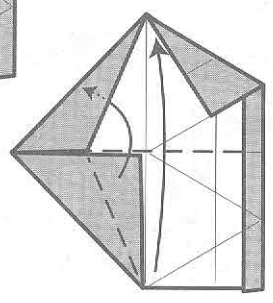
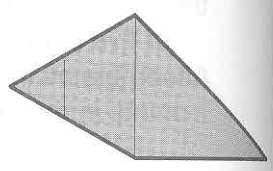
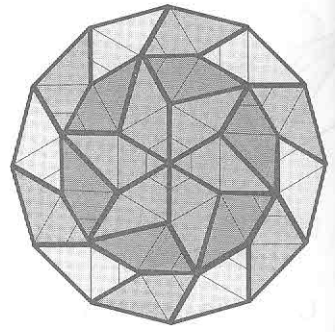
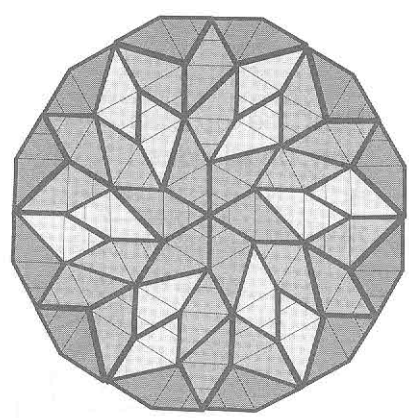

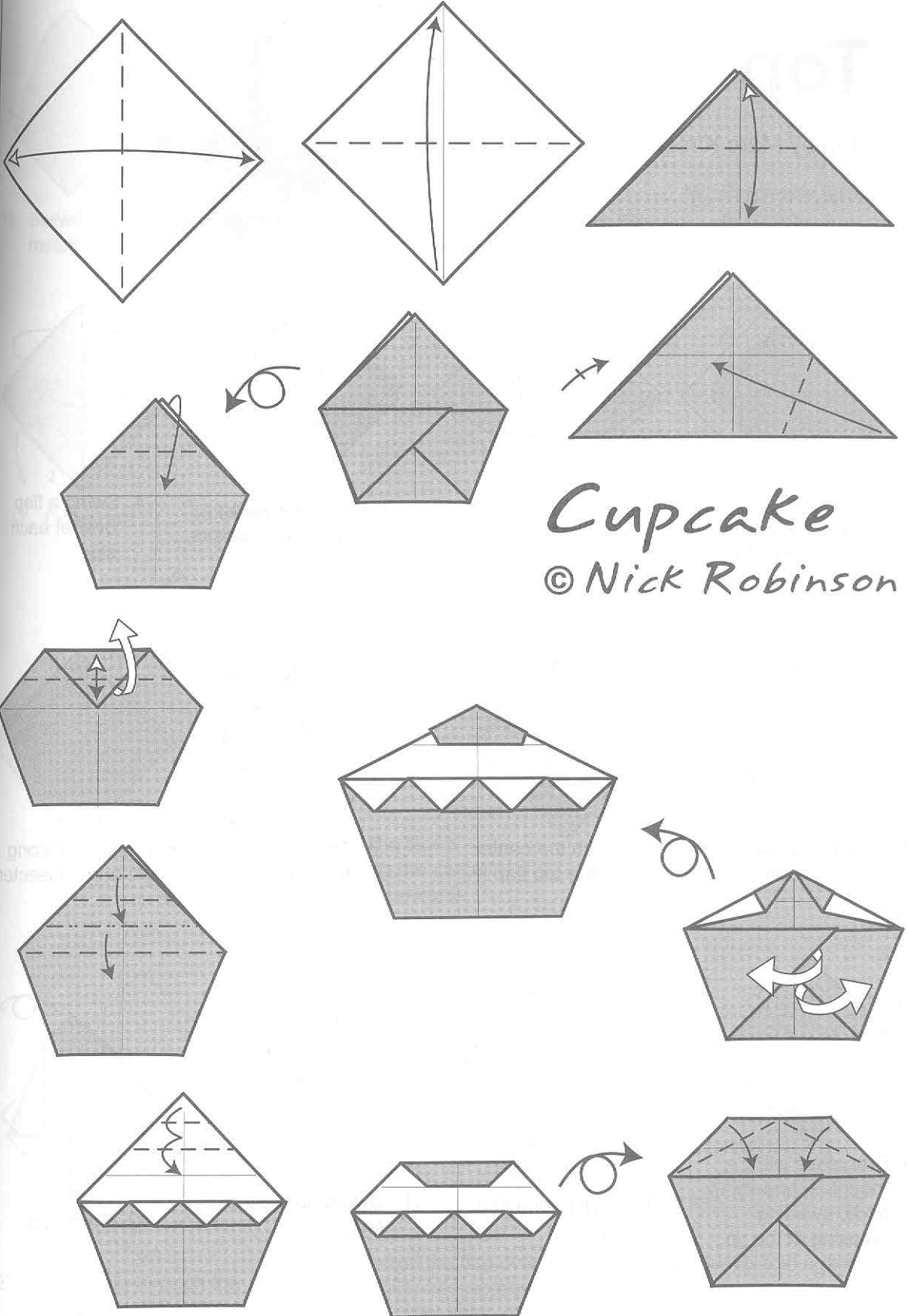

*Cupcake*  
© Nick Robinson



# Top

Top by Marc Kirschenbaum (NY) (c)2012

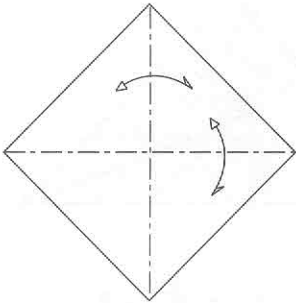
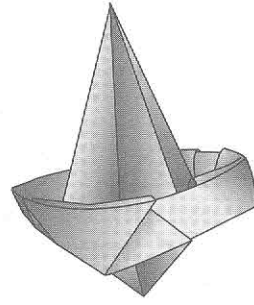

1. Precrease with mountain folds.

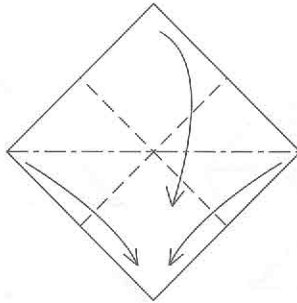

2. Collapse down.

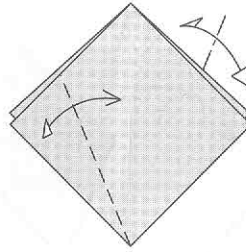

3. Precrease along the angle bisectors.

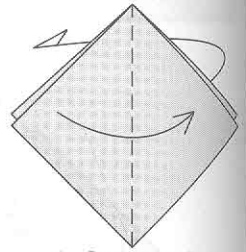

4. Swing a flap over at each side.

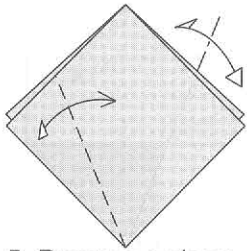

5. Precrease along the angle bisectors.

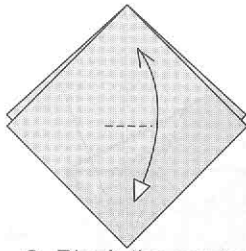

6. Pinch the center of the top flap.

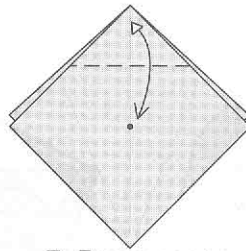

7. Precrease to the pinch.

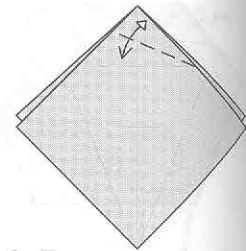

8. Precrease along the angle bisector.

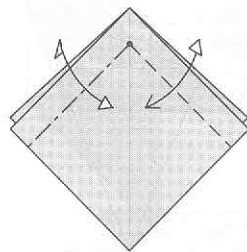

9. Precrease with mountain and valley folds, avoiding creasing at the tip.

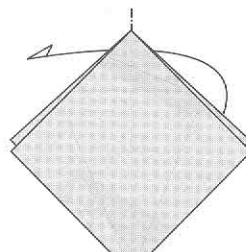

10. Swing one flap over.

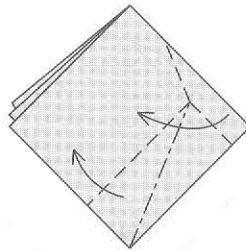

11. Swivel up the top layer.

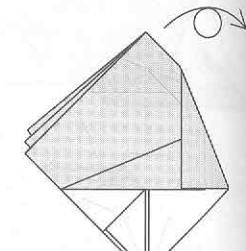

12. Turn over.

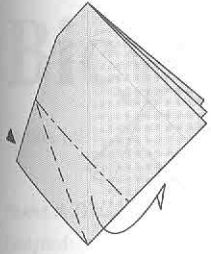

13. Swivel under to match the other side.

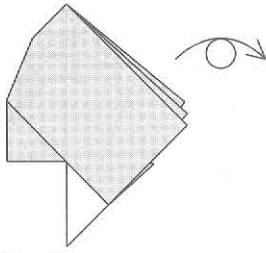

14. Turn over.

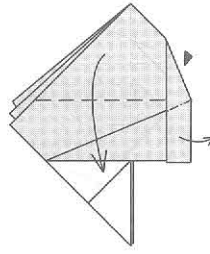

15. Squash the top down.

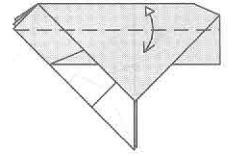

16. Precrease through all layers.

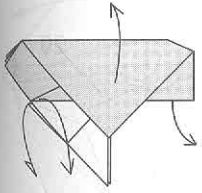

17. Open out.

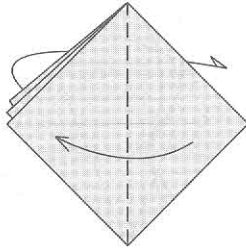

18. Swing over a flap at each side.

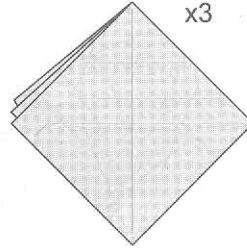

19. Repeat steps 11-18 three times.

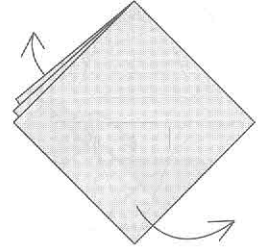

20. Unfold completely.

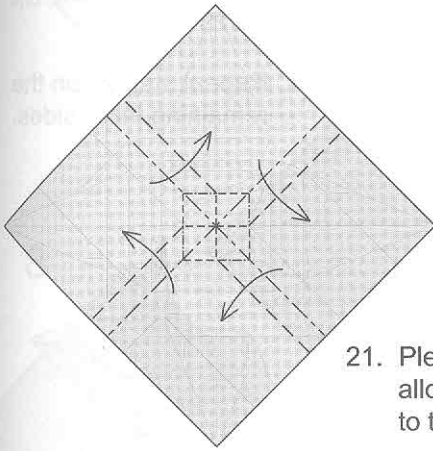

21. Pleat the sides, allowing the center to twist upwards.

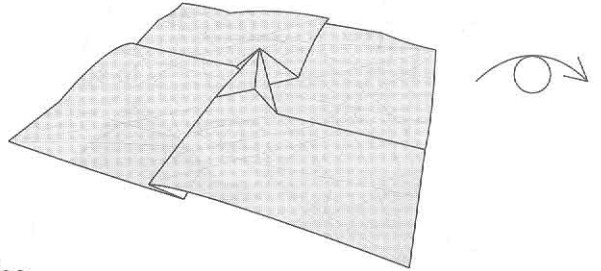

22. Turn over.

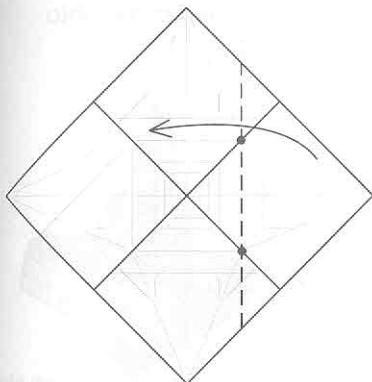

23. Valley fold through the indicated intersections.

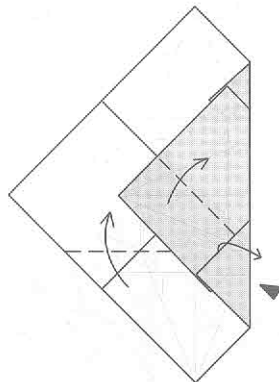

24. Swivel the flap over, using similar intersections on the other side.

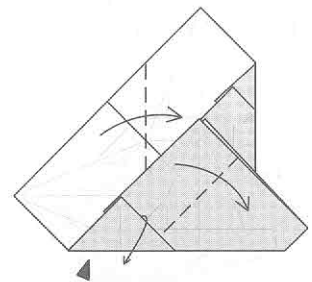

25. Swivel fold again.

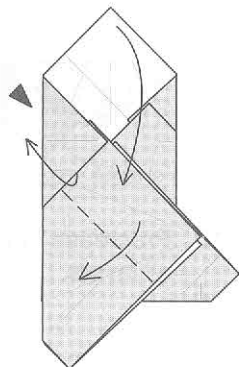

26. Swivel fold again.

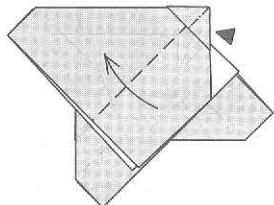

27. Squash fold.

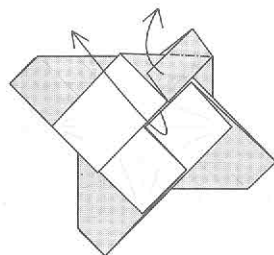

28. Pull out the hidden corner.

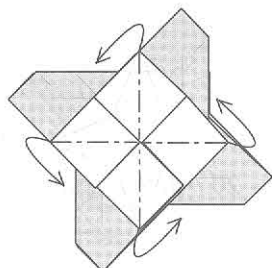

28. Raise the four center flaps, bringing the corners together.

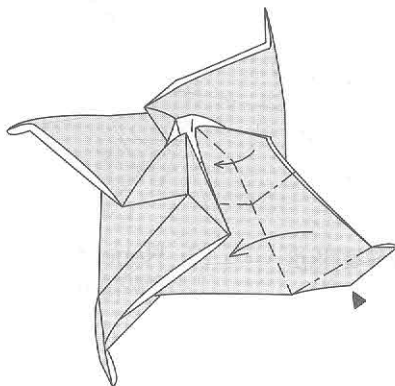

29. Valley fold inwards, allowing the outer portion to squash flat.

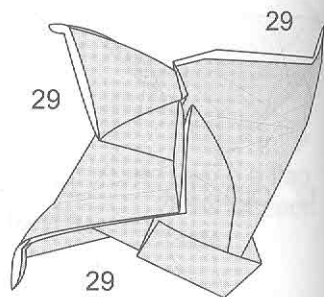

30. Repeat step 29 on the remaining three sides.

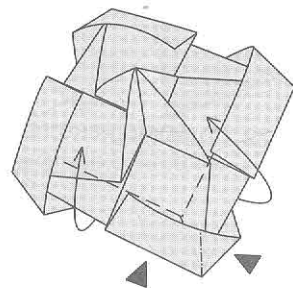

31. Valley fold the edges up while squashing the corner flat.

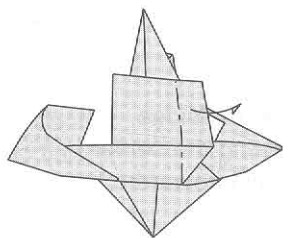

32. Mountain fold so that the flap is flush with the sides.

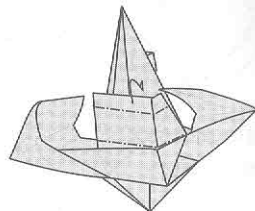

33. Mountain fold over and over, which will lock the corner into place.

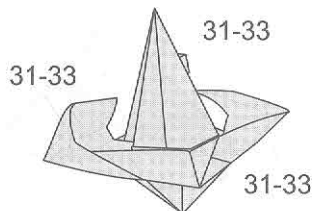

34. Repeat steps 31-33 on the remaining three corners.

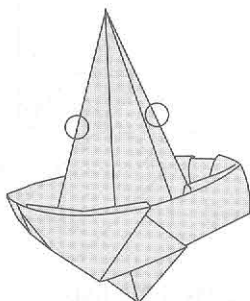

35. Hold by the indicated edges and spin.

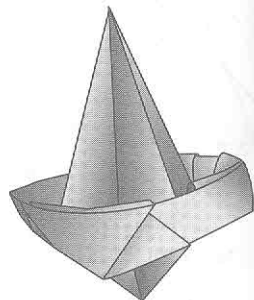

36. Completed Top.  
(c)2012 Marc Kirschenbaum

# Bicycle 自転車

Version 1.9

Model & Diagrams by Jason Ku

Designed: ©2013/06/05

Diagrammed: ©2013/06/08

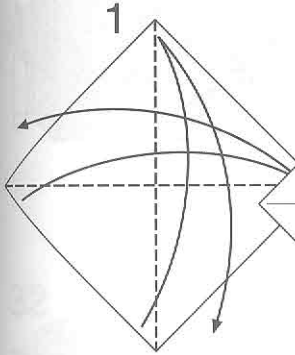
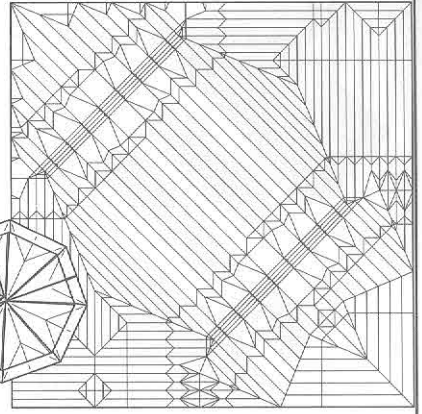
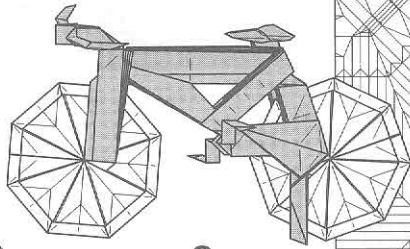

1  
Fold in half diagonally and unfold.

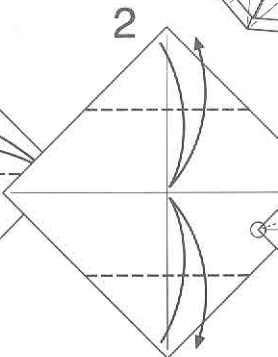

2  
Fold corners to the center and unfold.

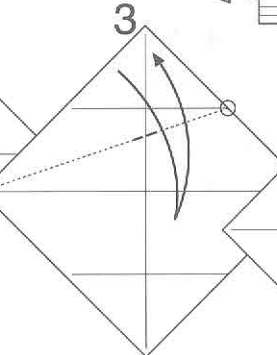

3  
Fold along a line connecting the circled point marking only in the center and unfold.

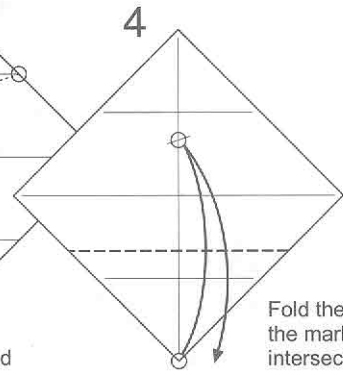

4  
Fold the corner to the marked intersection.

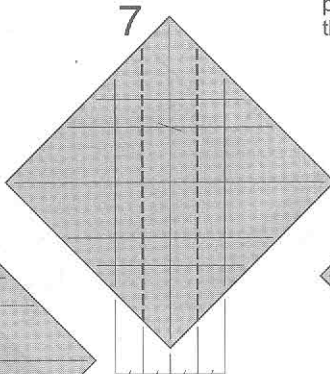

7  
Fold each section in half and unfold.

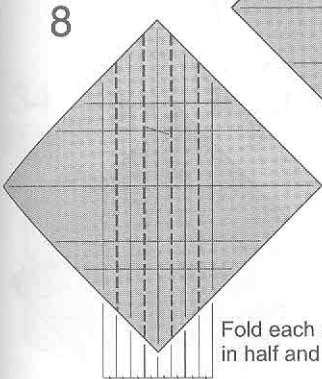

8  
Fold each section in half and unfold.

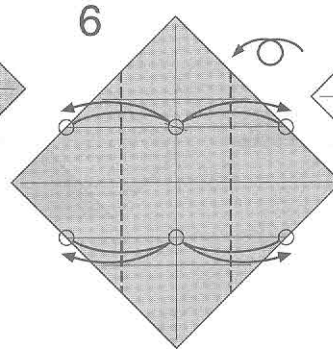

6  
Fold the circled points together and unfold.

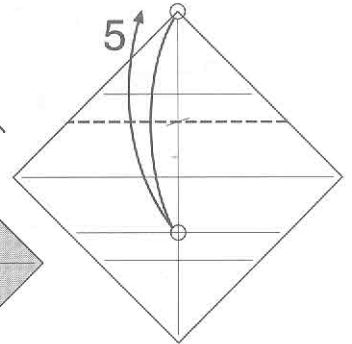

5  
Fold the corner to the intersection shown.

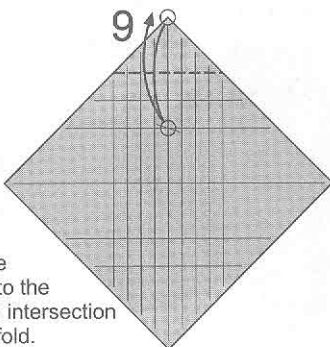

9  
Fold the corner to the marked intersection and unfold.

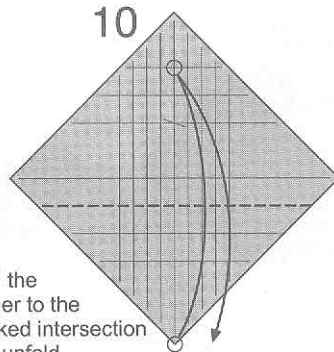

10  
Fold the corner to the marked intersection and unfold.

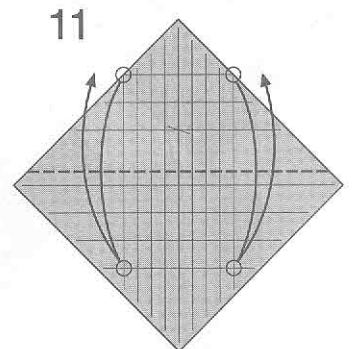

11

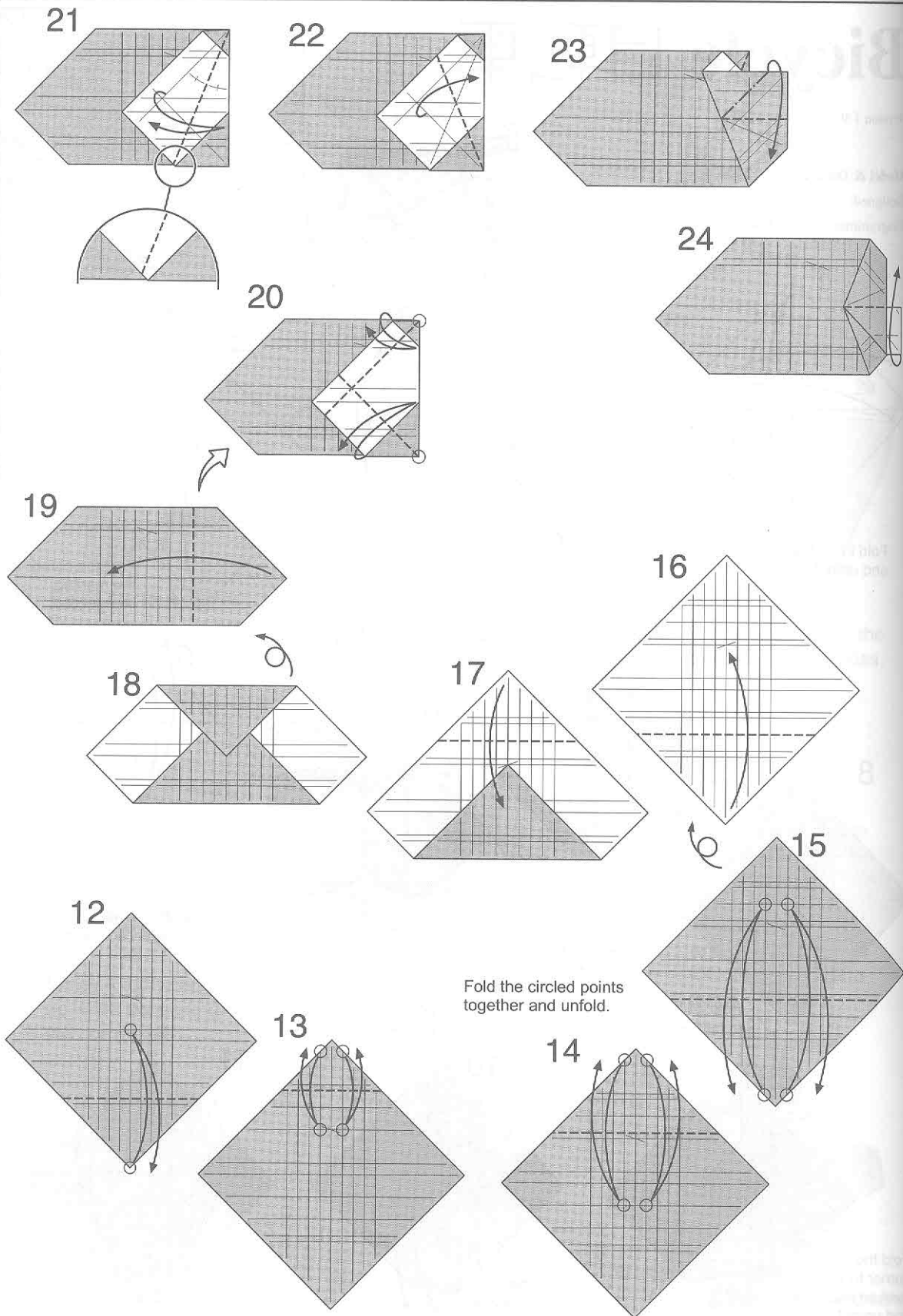

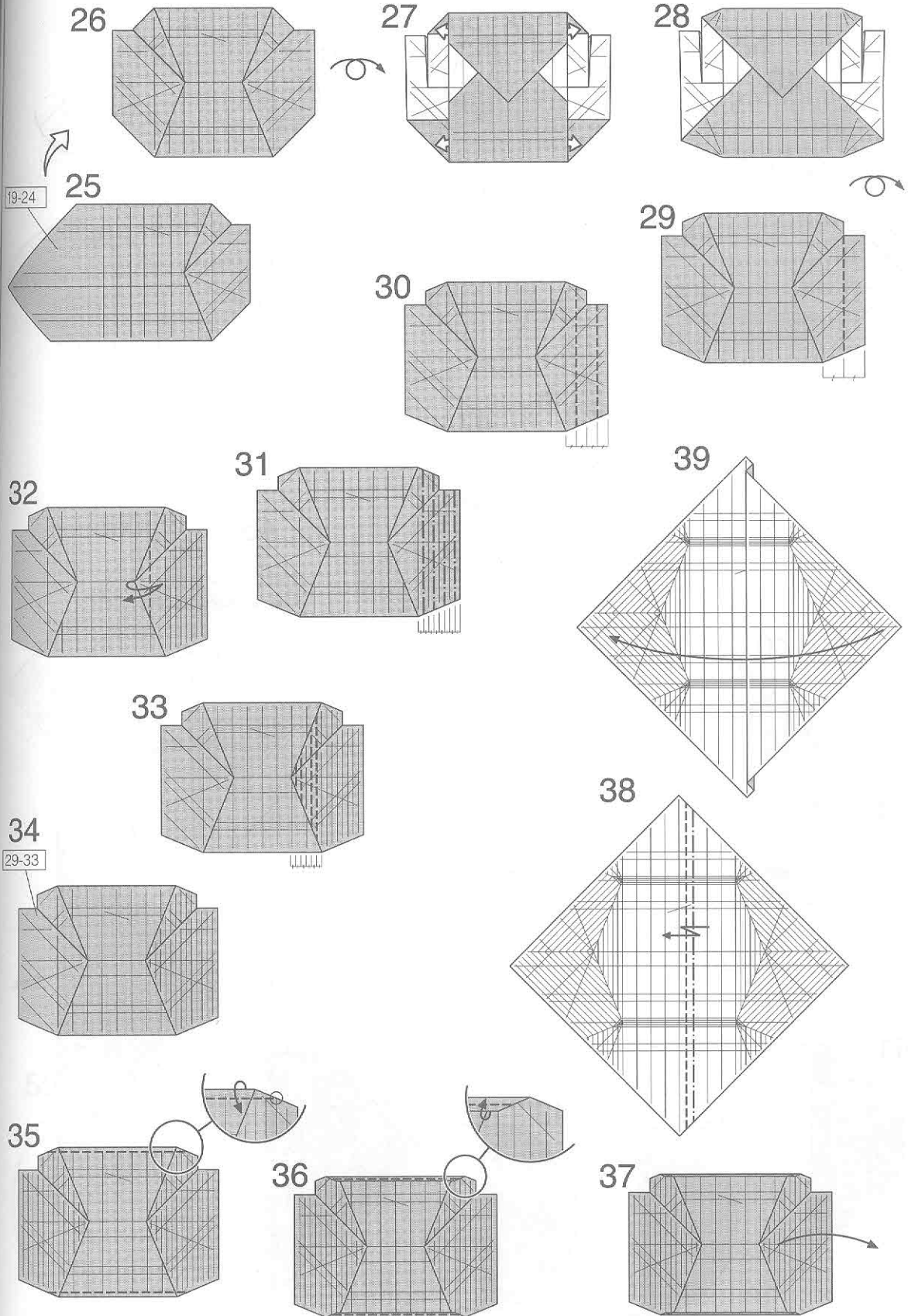

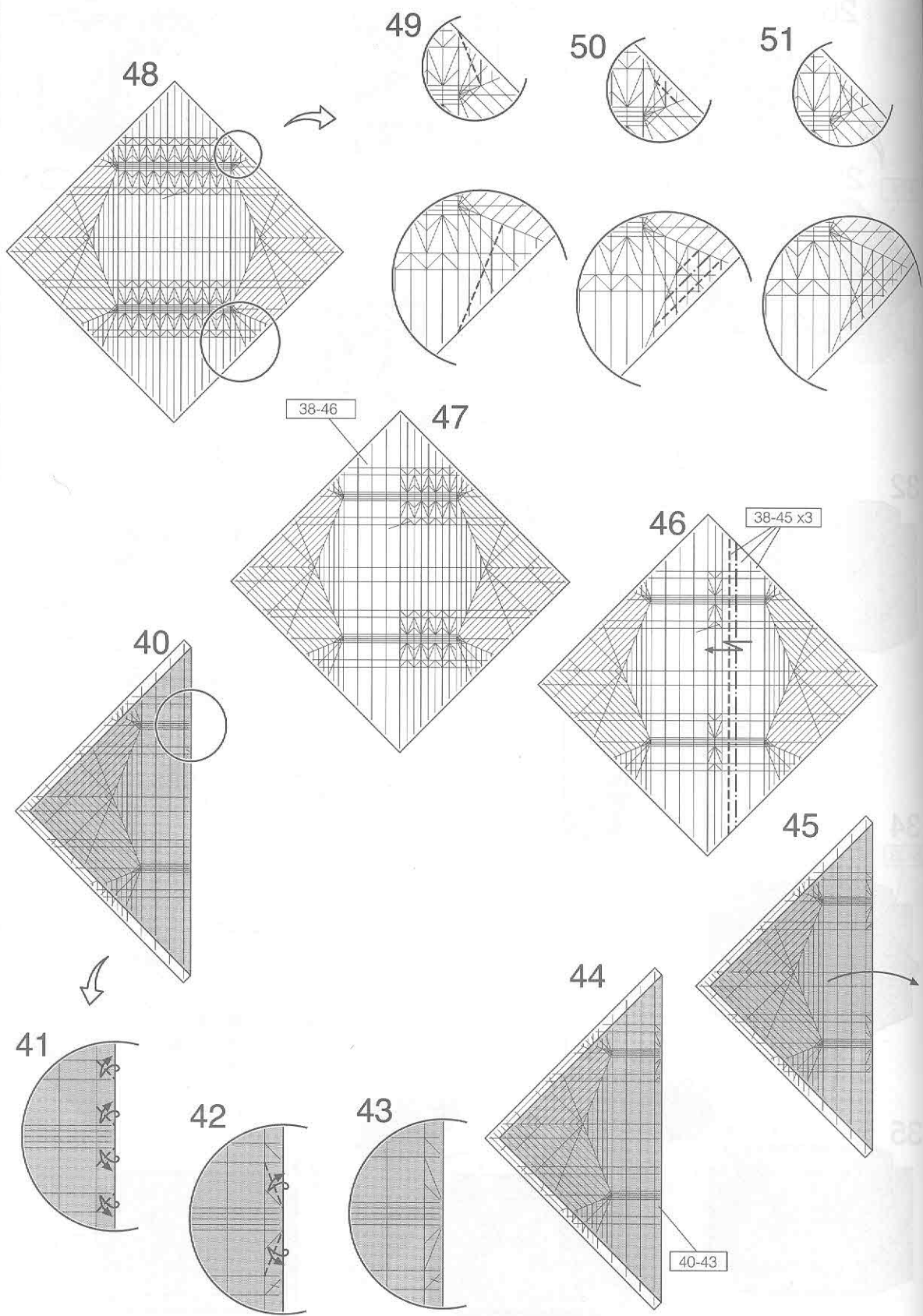

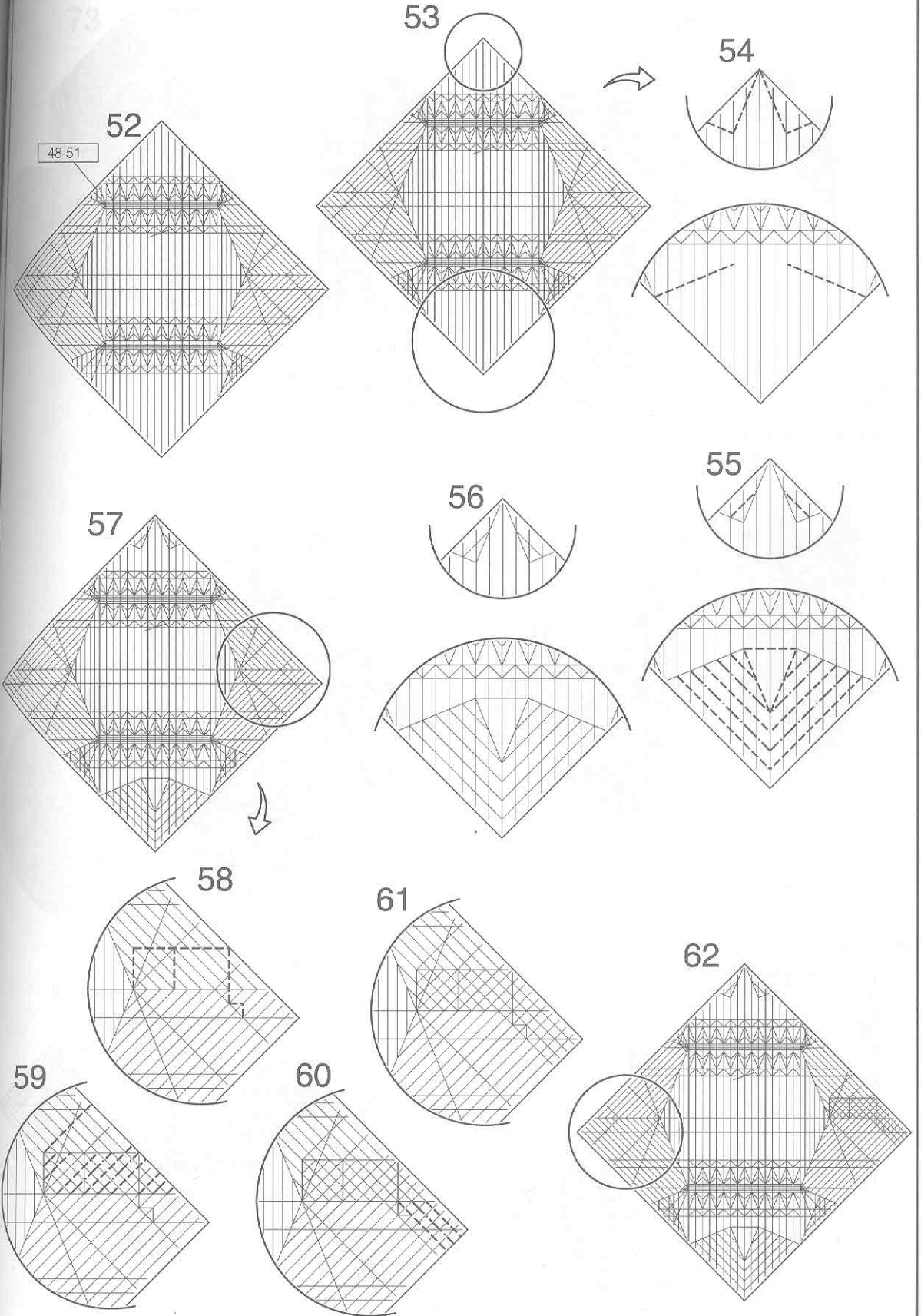



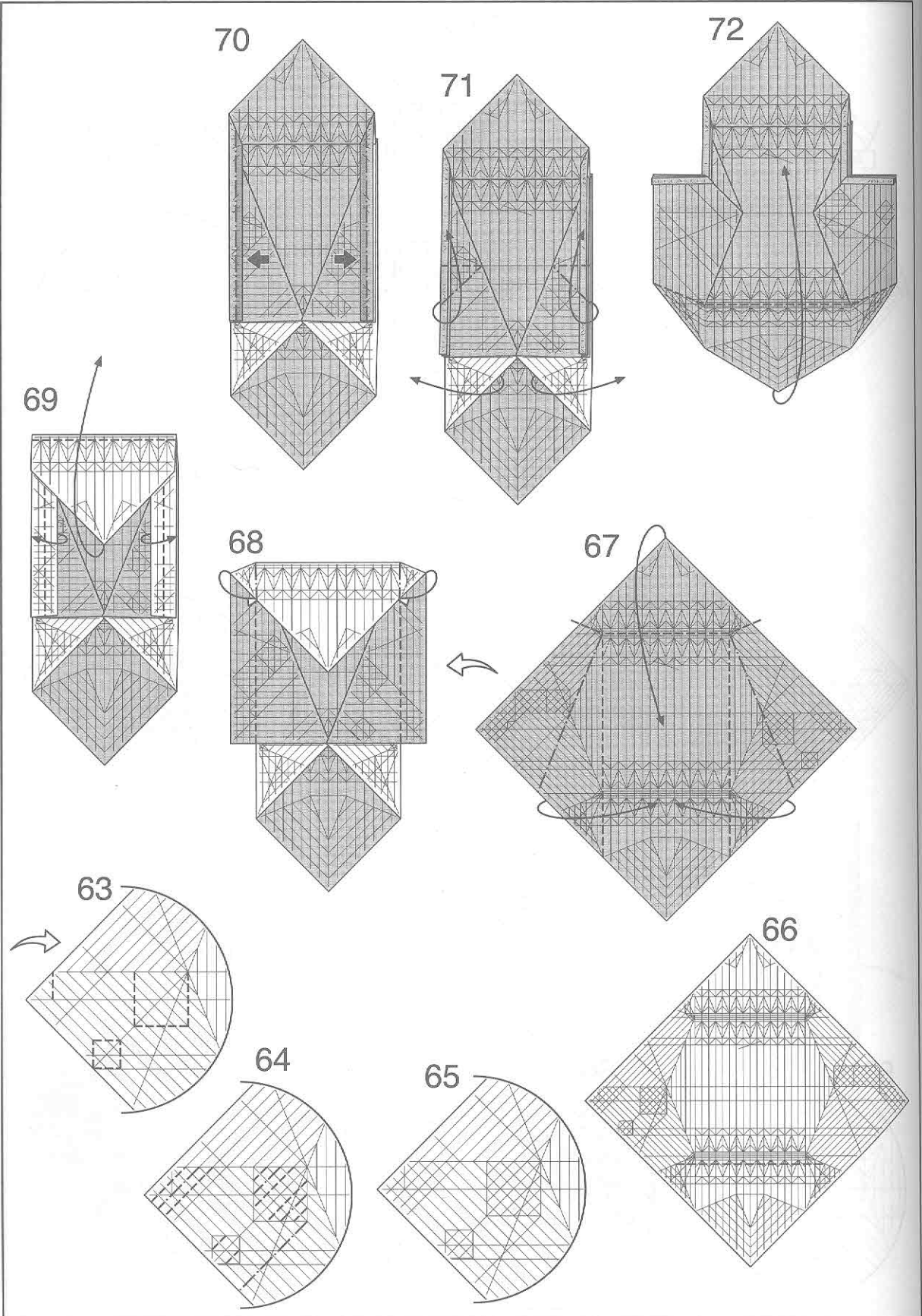

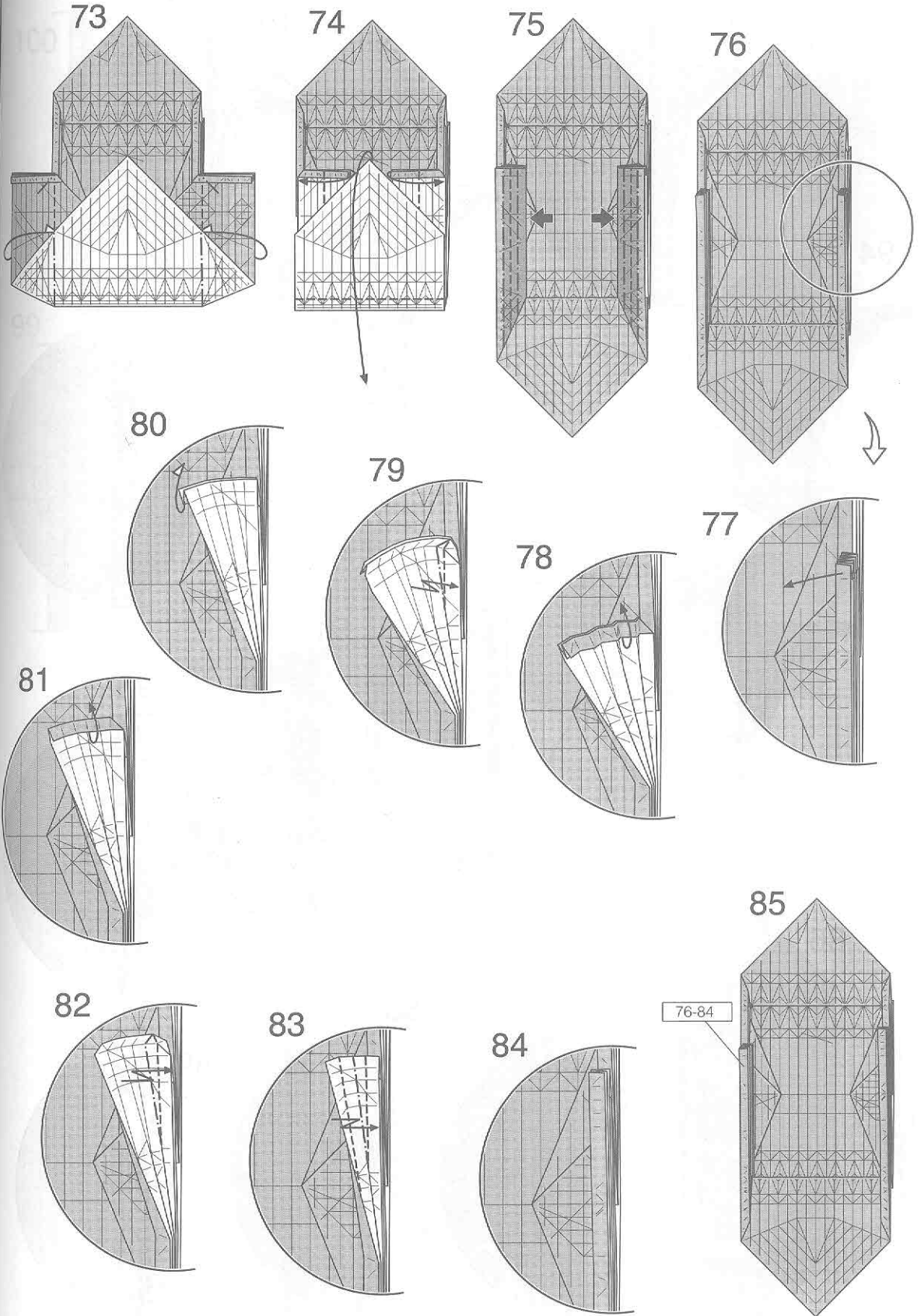

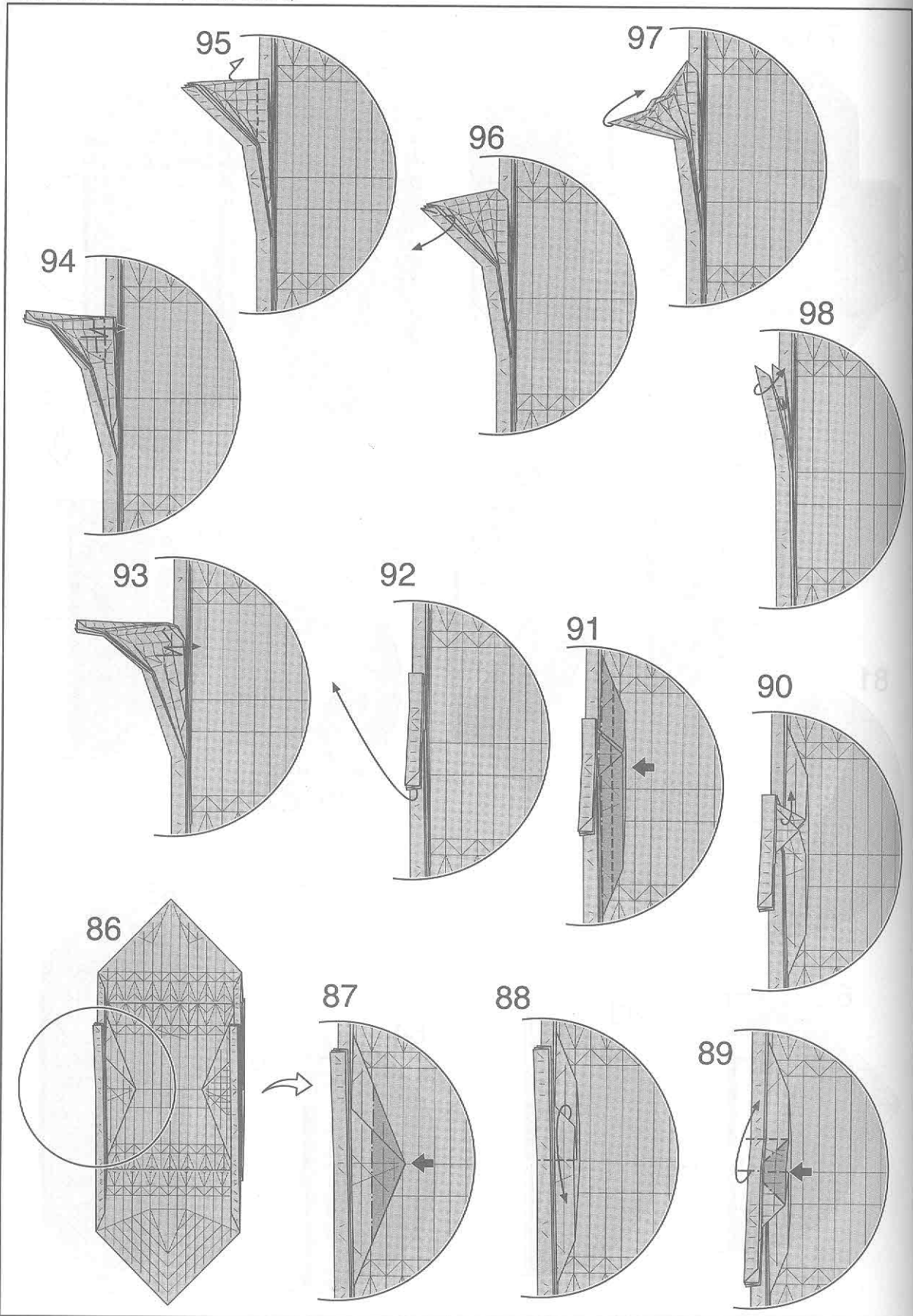

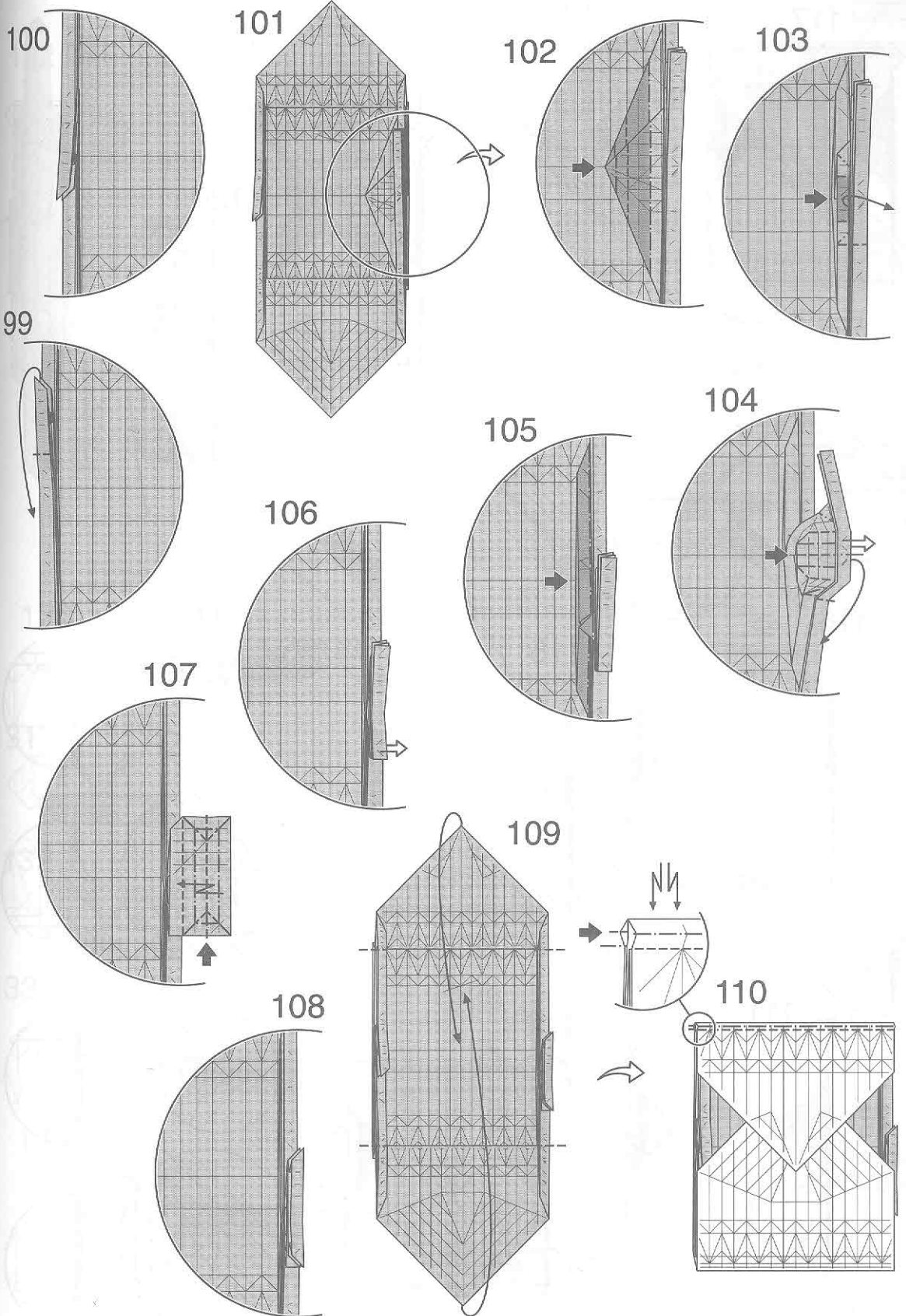

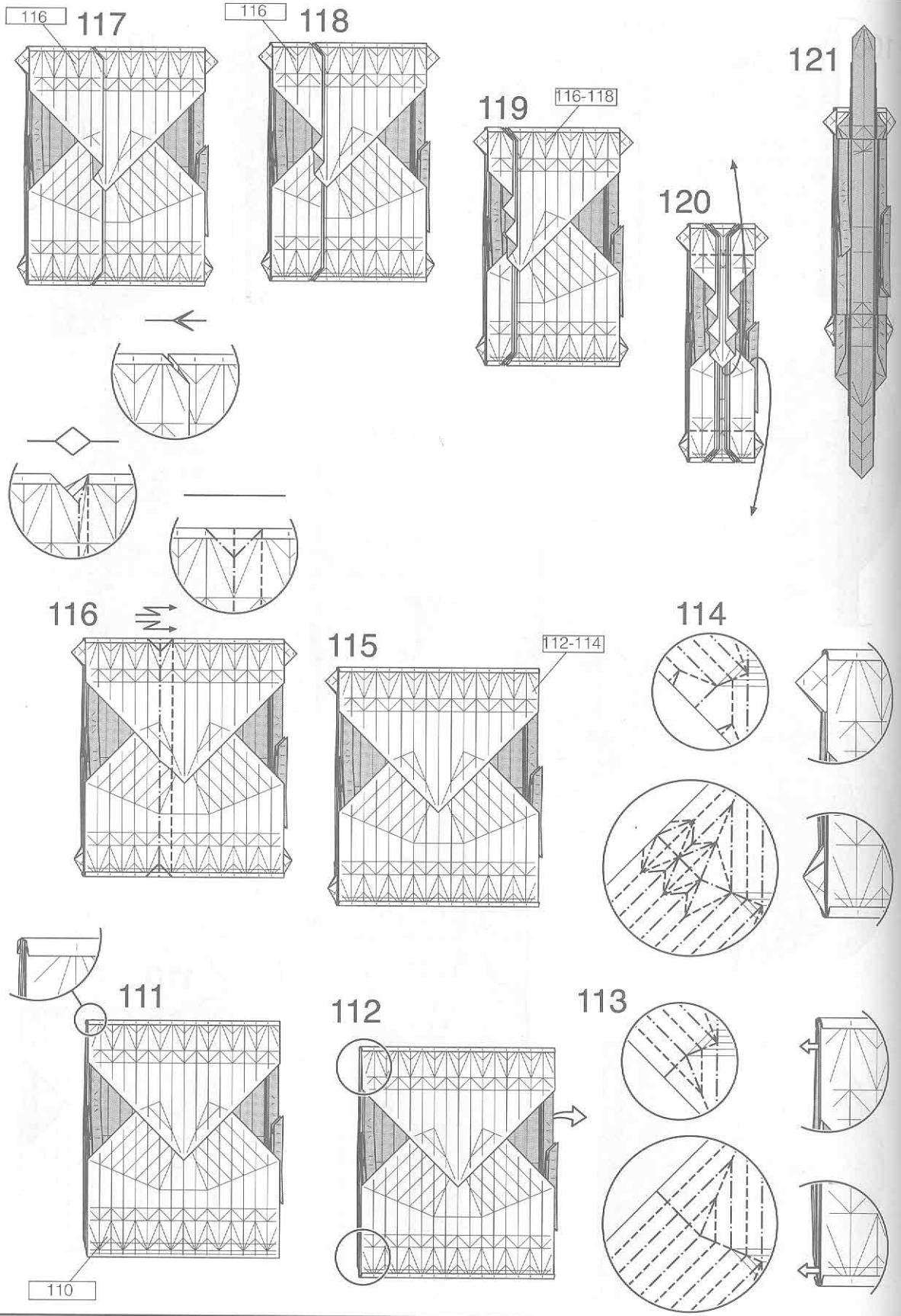

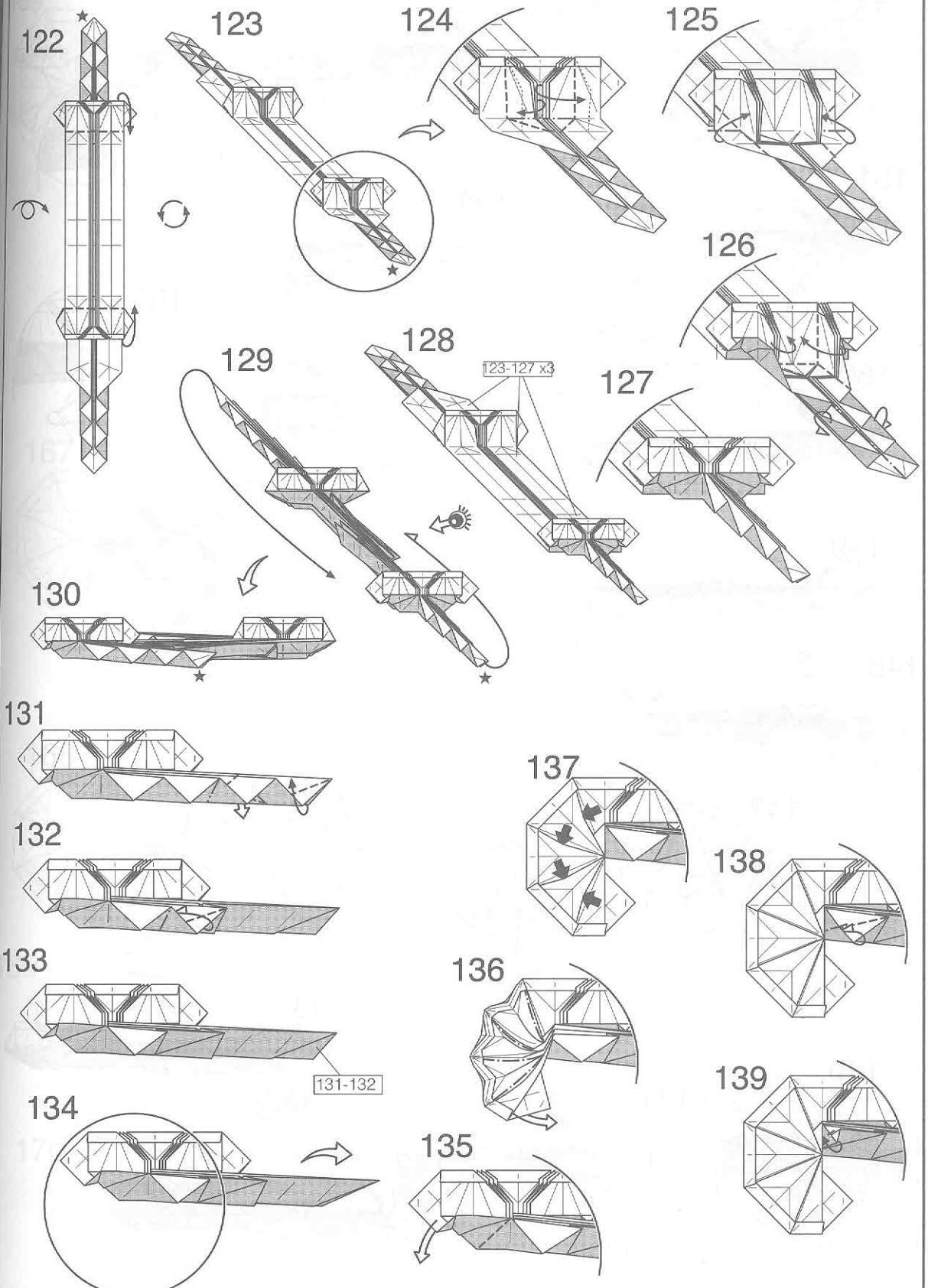

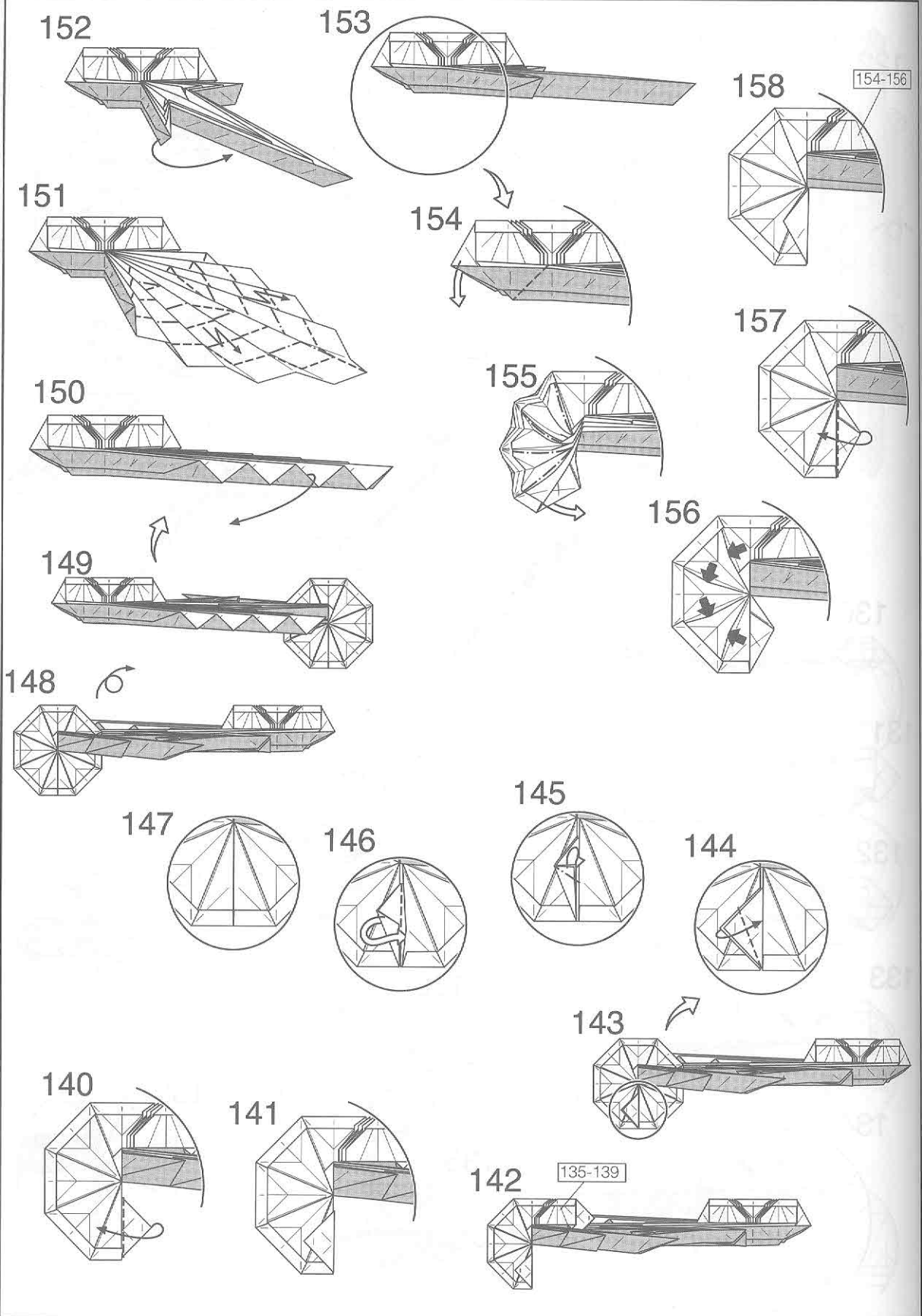

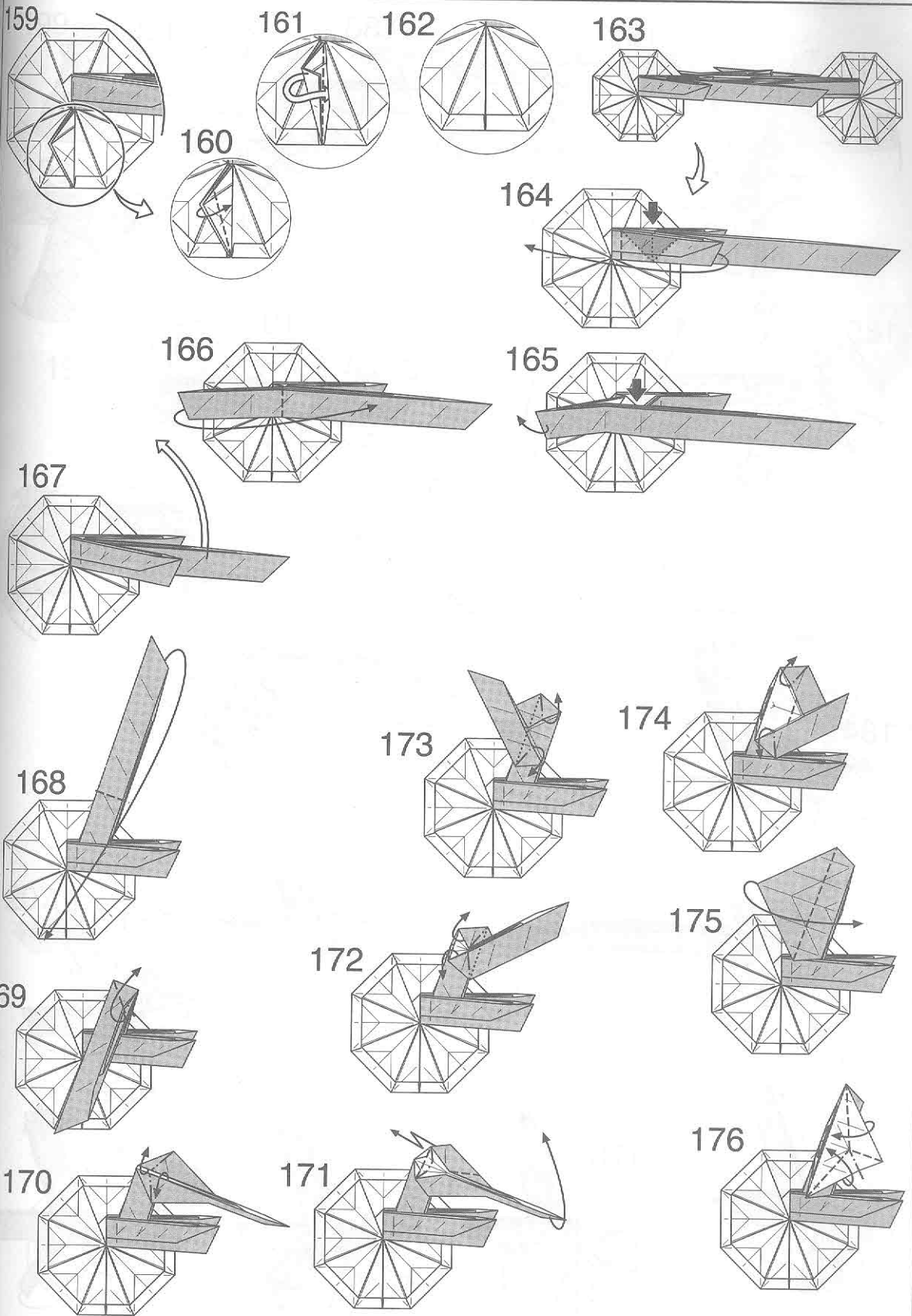



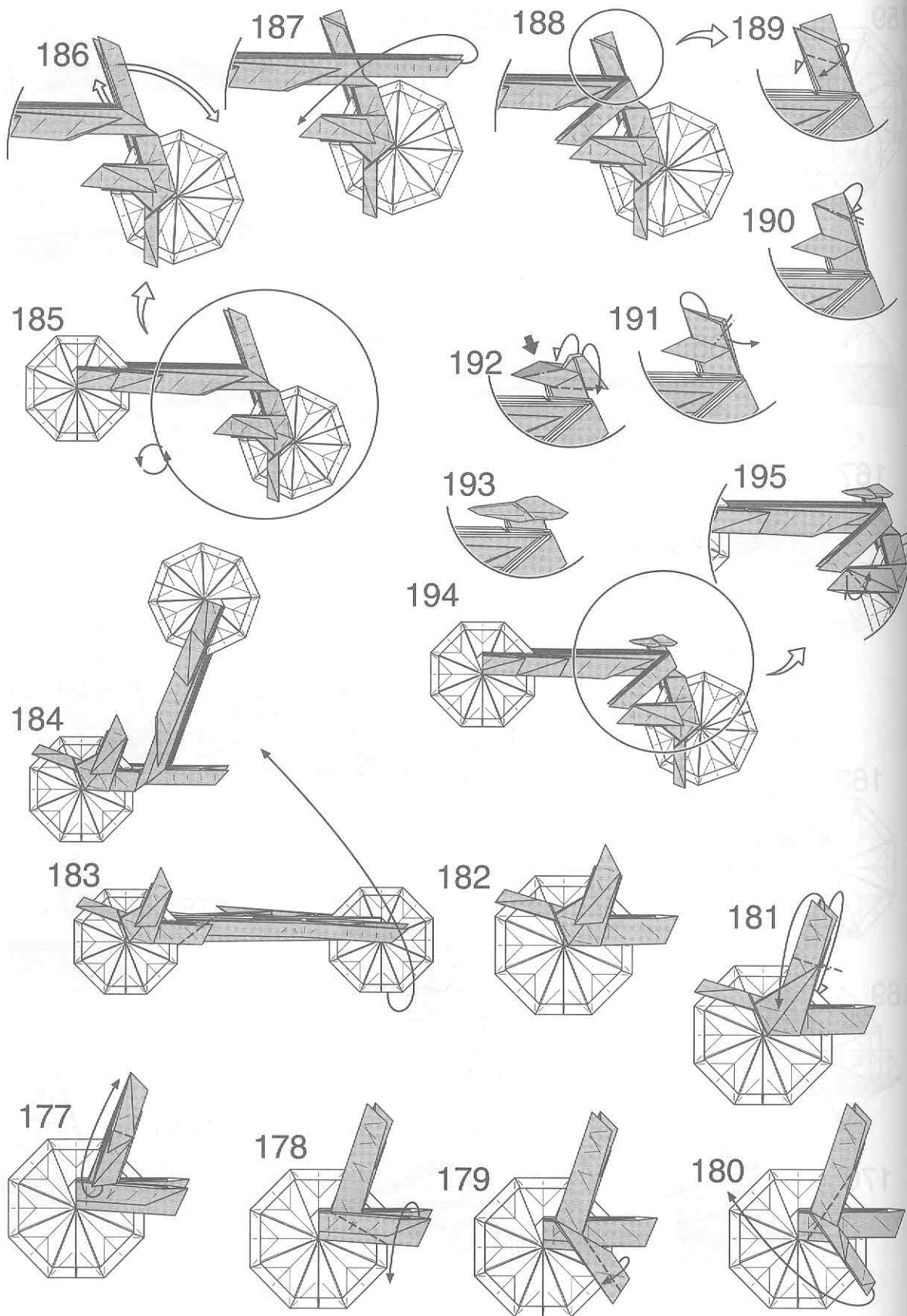

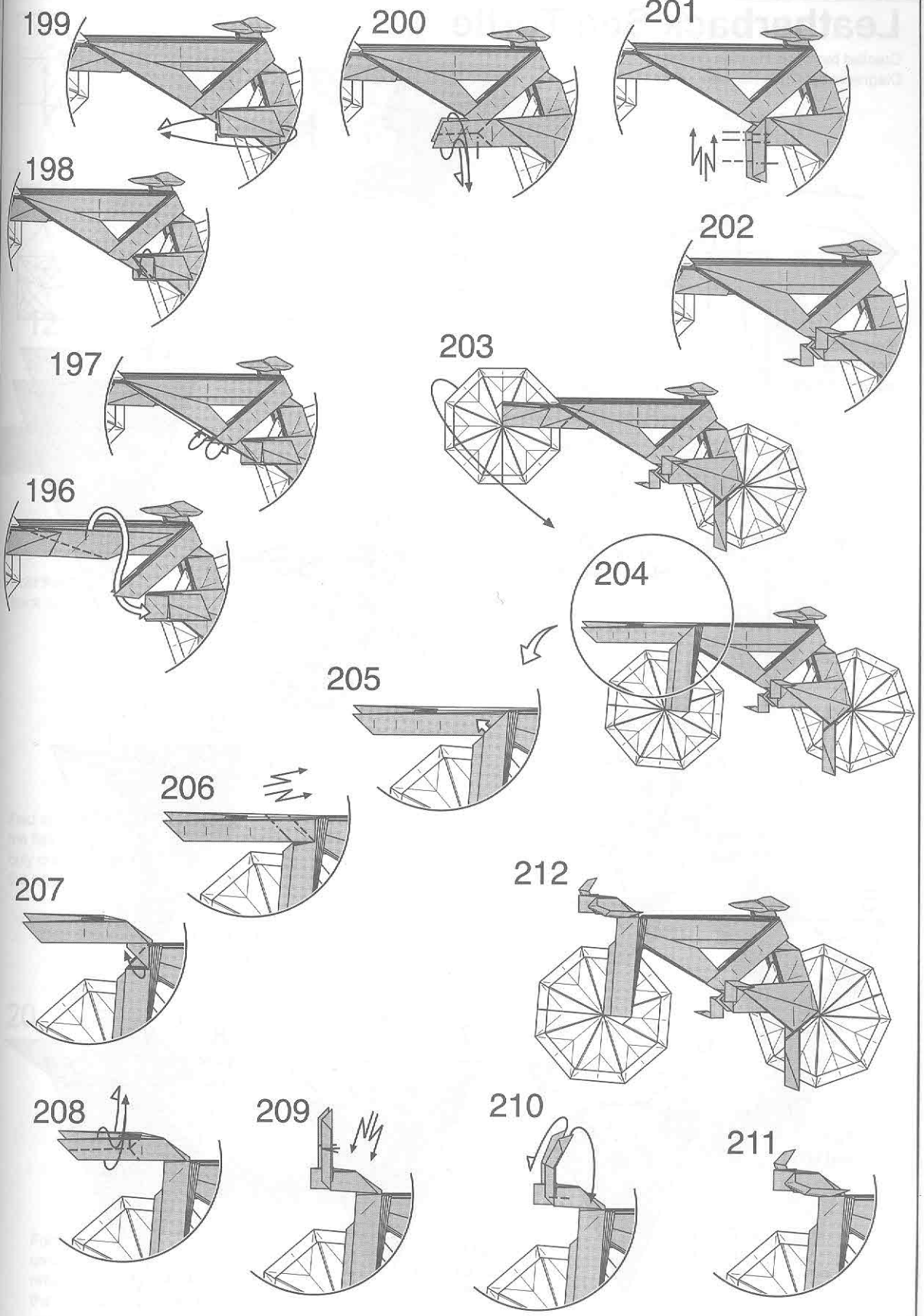

# Leatherback Sea Turtle

Created by: Chris Heynen (2011)  
Diagrams by: Chris Heynen

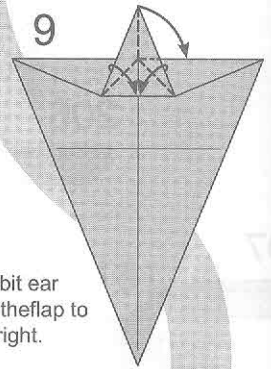
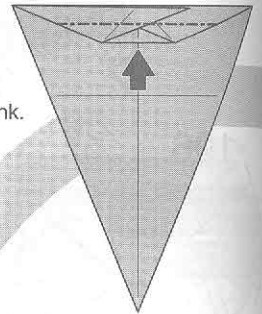
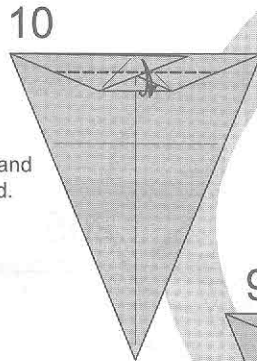
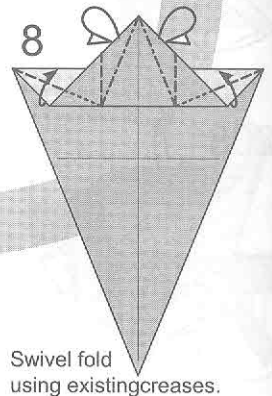
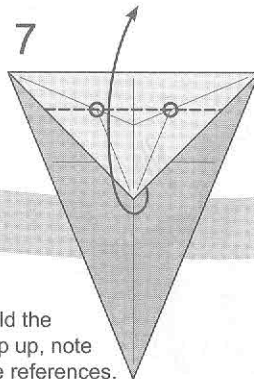
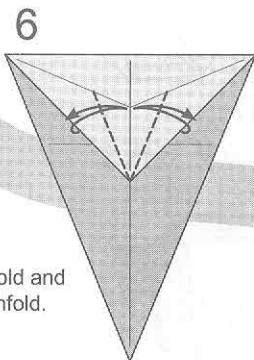
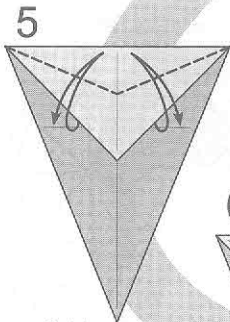
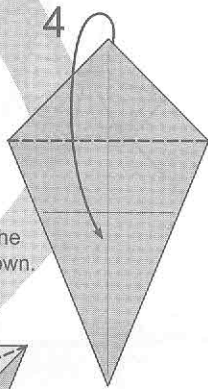
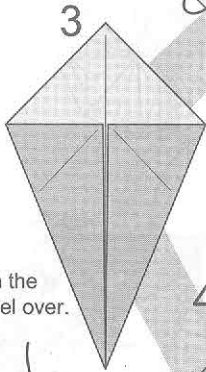
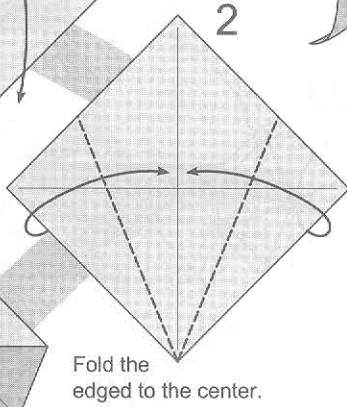
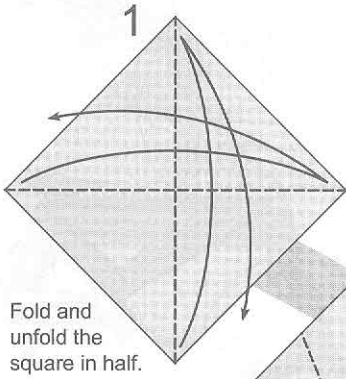
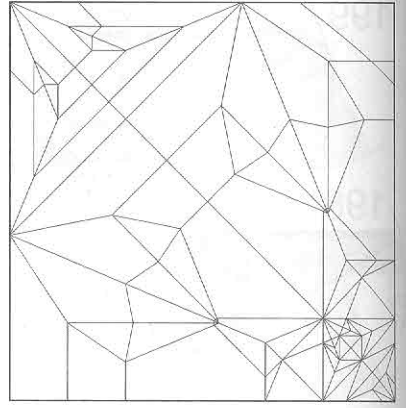
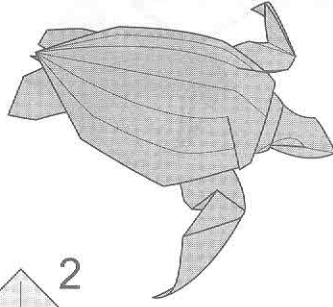

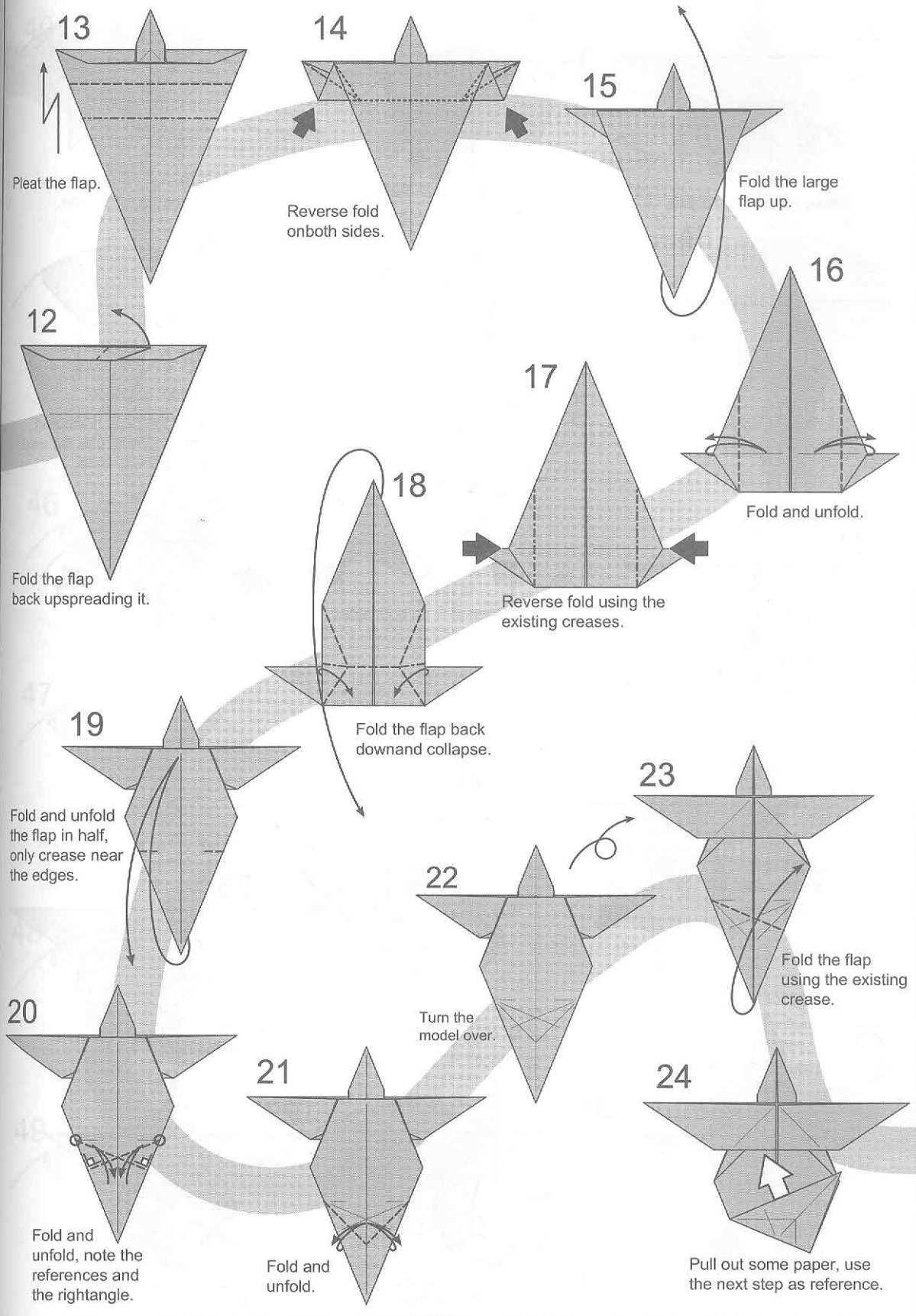

33

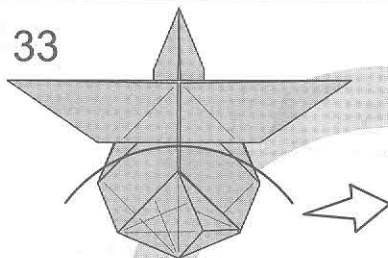

Focus on the circled part.

34

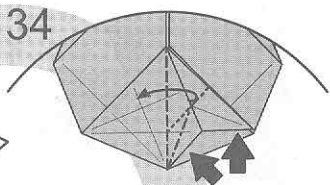

Perform two squash folds at the same time.

39

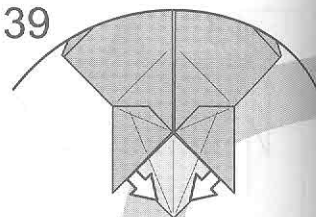

Bring one layer to the front on each side.

32

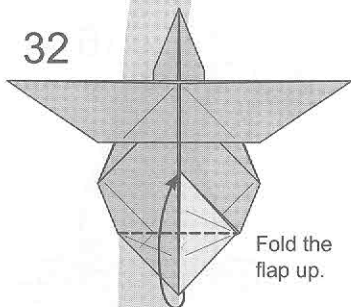

Fold the flap up.

35

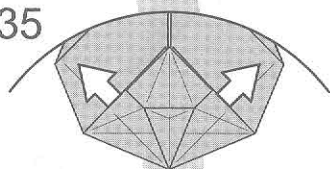

Pull out some paper on both sides, use the next step as reference.

38

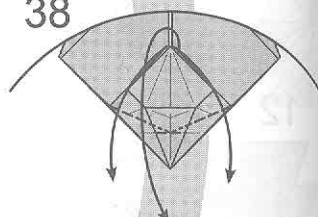

Fold the flaps down and spread them, use the next step as reference.

31

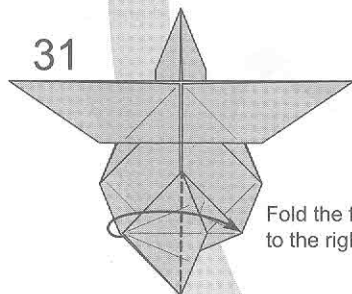

Fold the flap to the right.

36

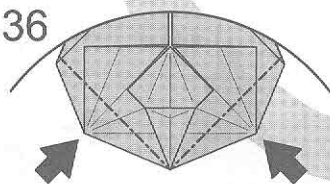

Open sink on both sides.

37

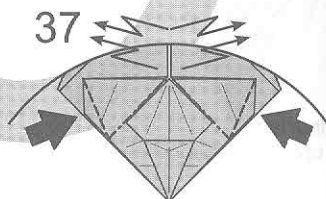

Crimp the flaps.

30

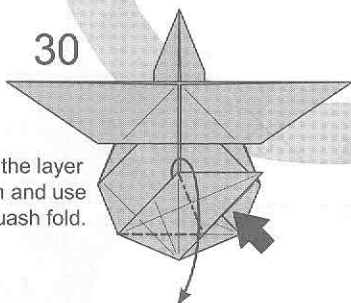

Fold the layer down and use a squash fold.

29

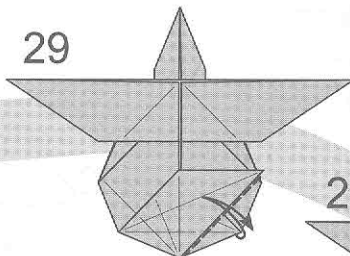

Fold and unfold along the edge.

28

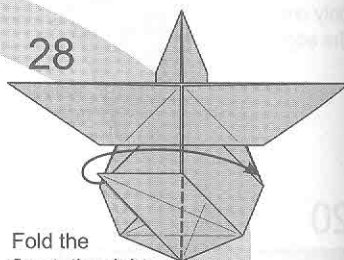

Fold the flap to the right.

25

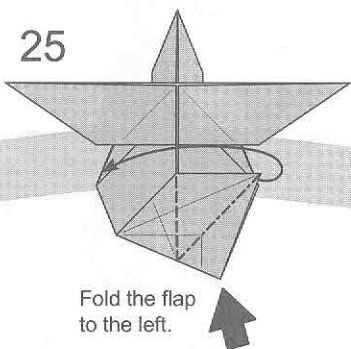

Fold the flap to the left.

26

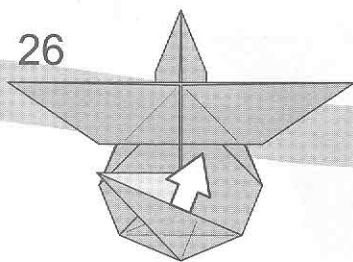

Pull out some paper, use the next step as reference.

27

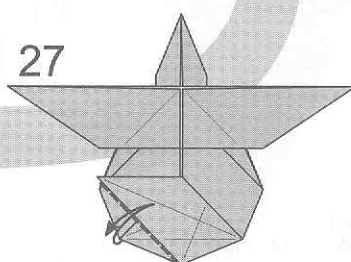

Fold and unfold along the edge of the paper.

40

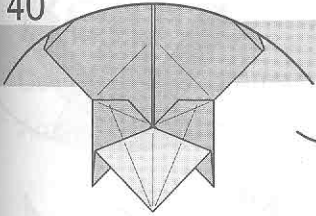

The result, turn the model over.

41

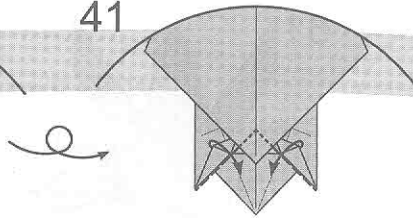

Fold to the middle.

42

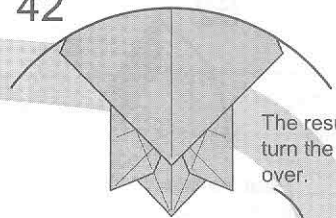

The result, turn the model over.

43

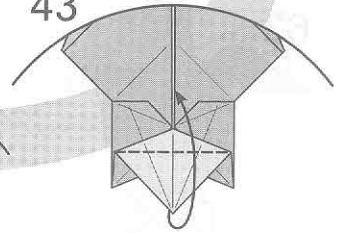

Fold the flap up.

45

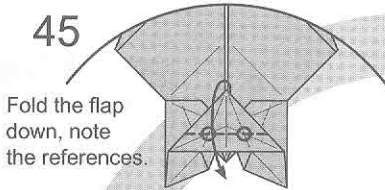

Fold the flap down, note the references.

44

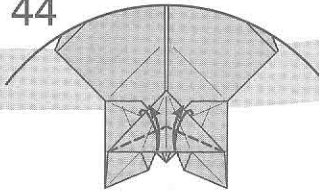

Fold and unfold.

46

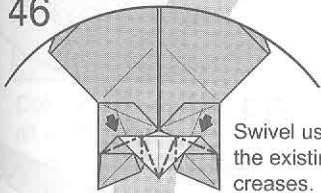

Swivel using the existing creases.

52

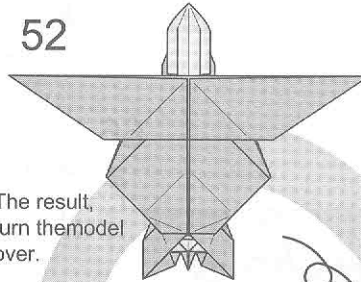

The result, turn the model over.

47

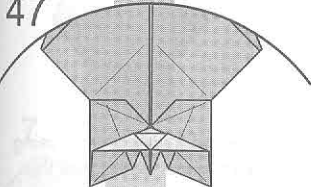

Bring one layer to the front on each side, use the next step as reference.

51

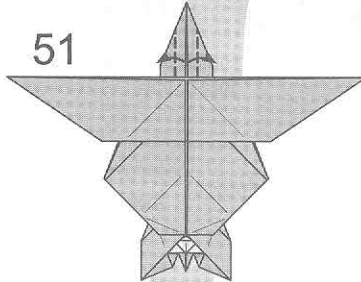

Open up the top flap, the result will not lie flat.

53

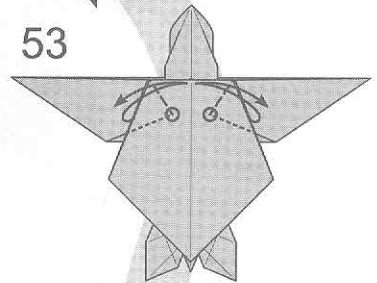

Fold and unfold, note the references.

48

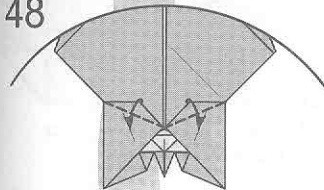

Fold the little flaps down.

49

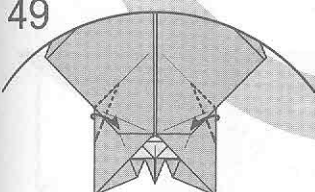

Fold the edges in.

50

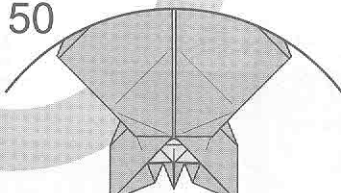

The result, focus on the entire model again.

54

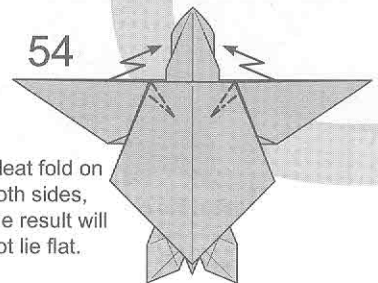

Pleat fold on both sides, the result will not lie flat.

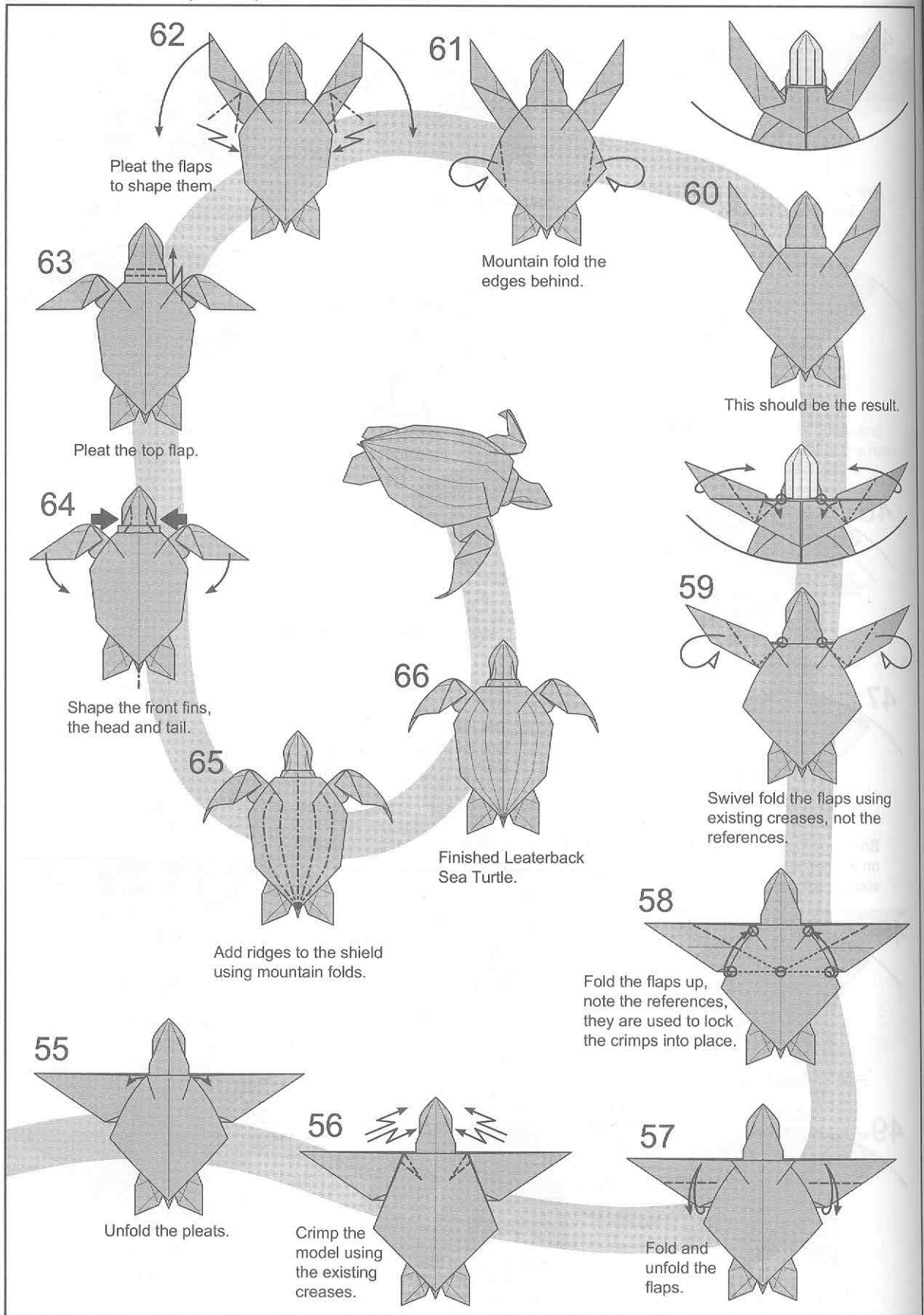

# Beluga

Design and diagrams by Ryan Welsh  
Amsterdam, The Netherlands

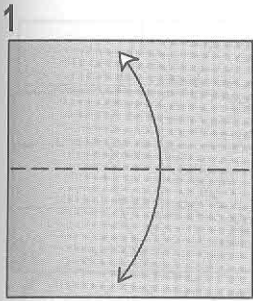
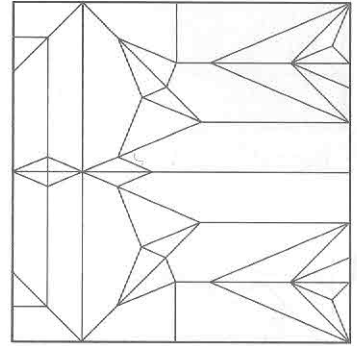
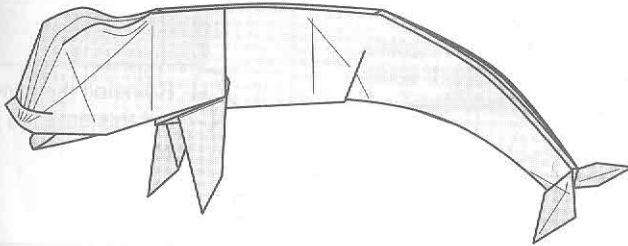

1  
Colored side up for an all white model.  
Fold and unfold in half.

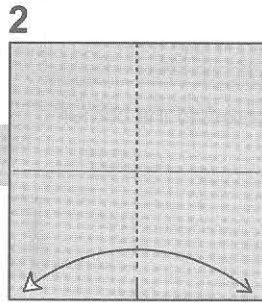

2  
Mark the midpoint of the lower edge.

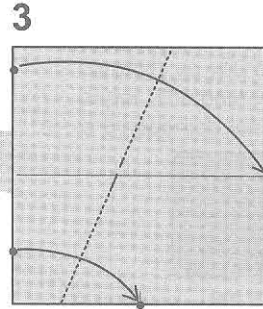

3  
Bring the left edge to the marks.  
Only sharpen the crease in the center.

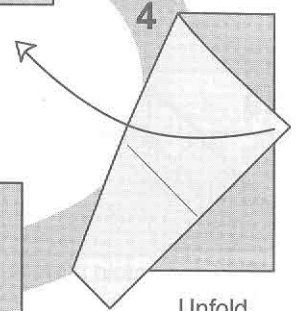

4  
Unfold.

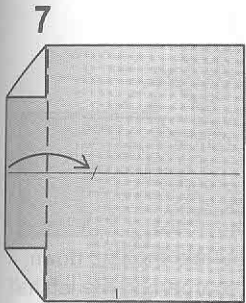

7  
Refold the edge.

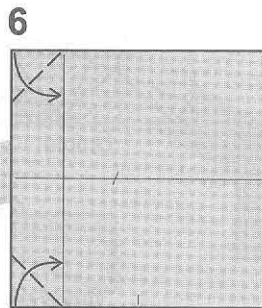

6  
Fold the corners.

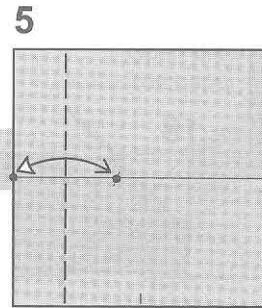

5  
Crease the edge using the landmark you just made.

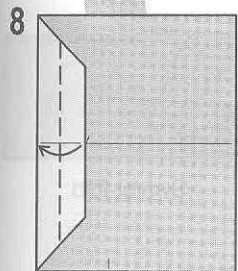

8  
Valley-fold in half.

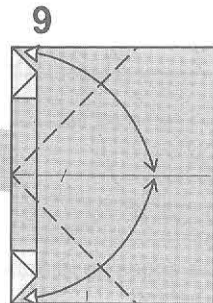

9  
Fold and unfold. Turn over.

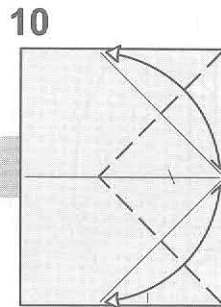
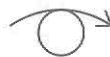

10  
Fold and unfold.

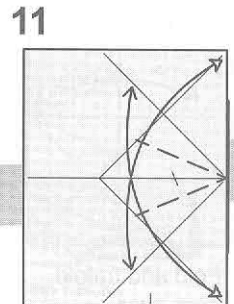

11  
Fold and unfold.



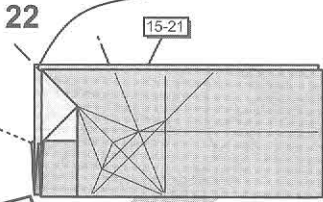
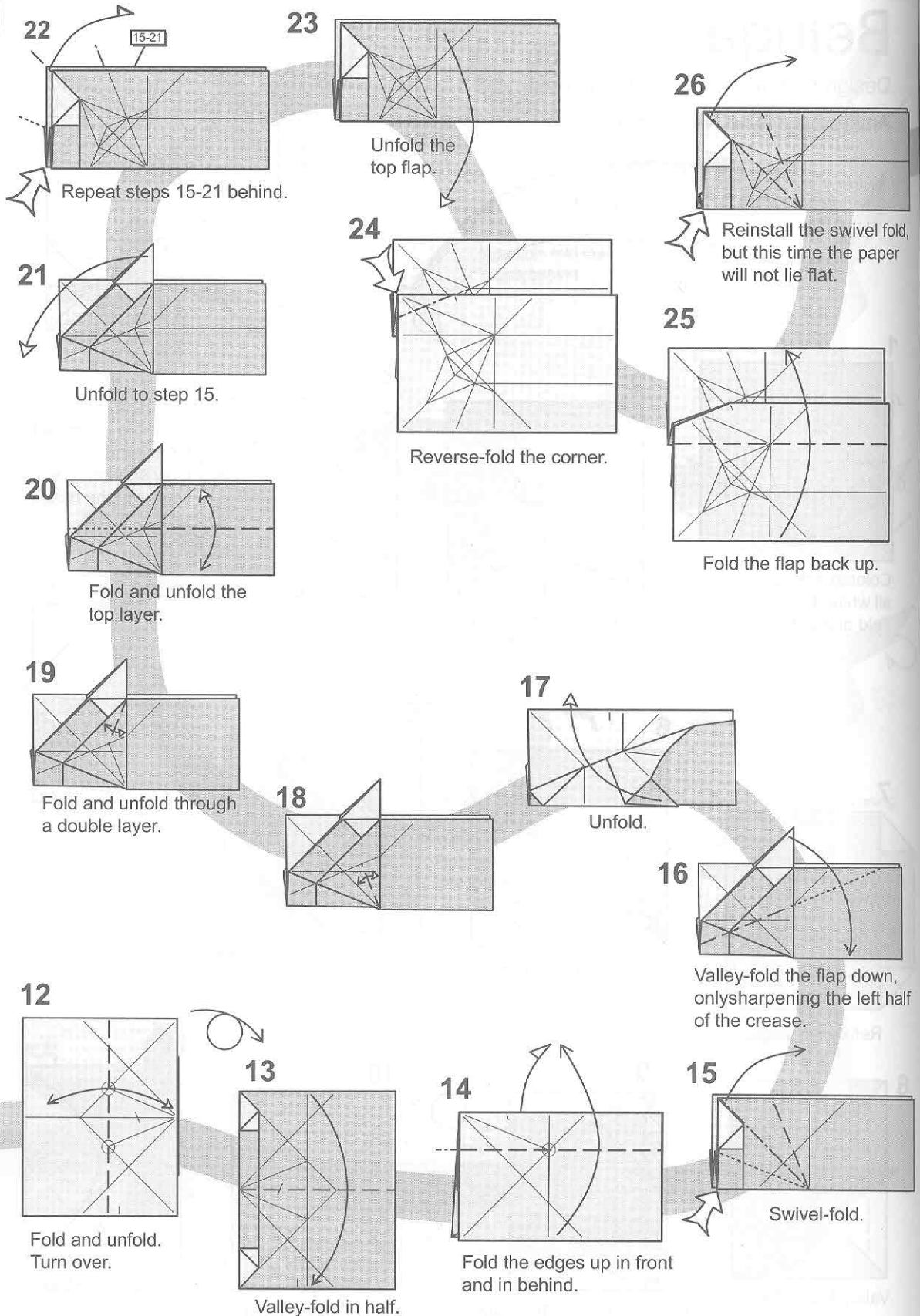

Repeat steps 15-21 behind.

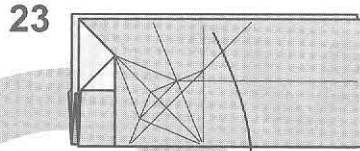

Unfold the top flap.

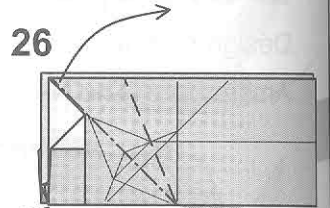

Reinstall the swivel fold, but this time the paper will not lie flat.

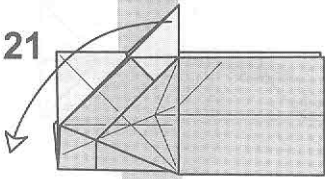

Unfold to step 15.

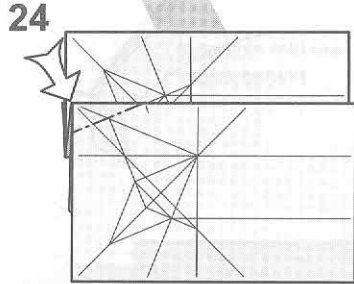

Reverse-fold the corner.

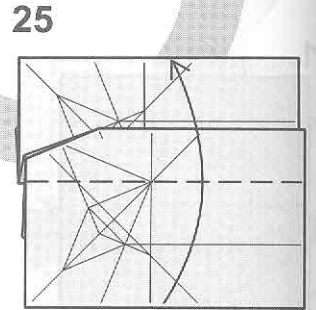

Fold the flap back up.

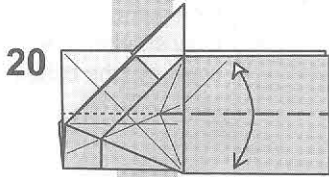

Fold and unfold the top layer.

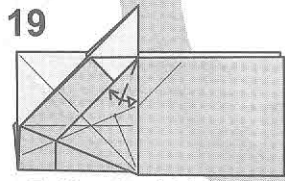

Fold and unfold through a double layer.

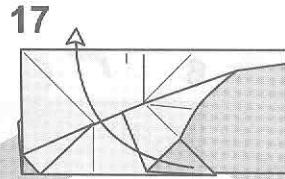

Unfold.

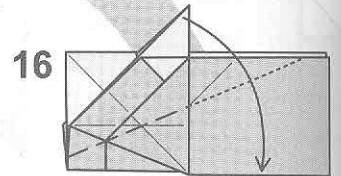
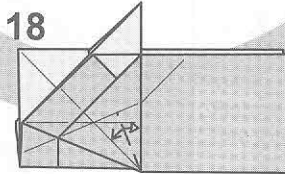

Valley-fold the flap down, only sharpening the left half of the crease.

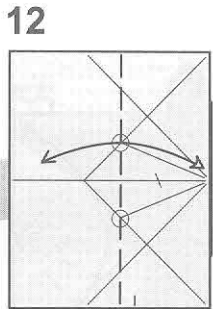

Fold and unfold. Turn over.

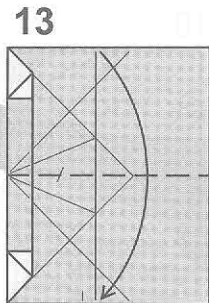

Valley-fold in half.

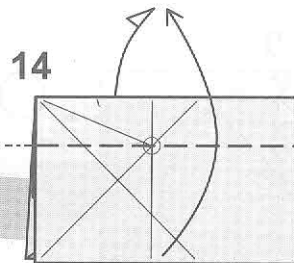

Fold the edges up in front and in behind.

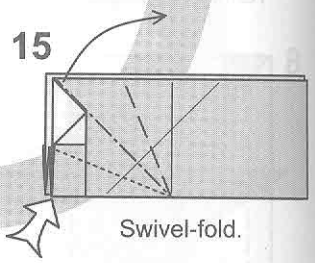

Swivel-fold.

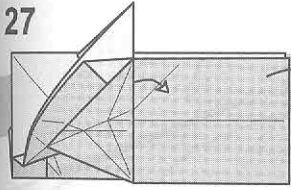

27

Open the flap.

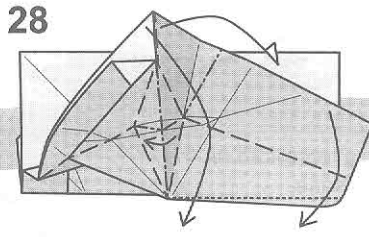

28

Using only existing creases close the flap, incorporating the folds shown.

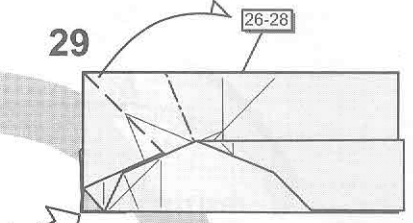

29

Repeat steps 26-28 behind.

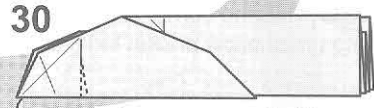

30

Pull out some paper that is trapped in the corner. Do this carefully so you don't tear the paper. The best way to do this is by opening the model somewhat.

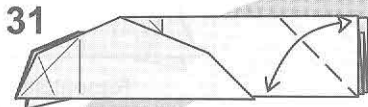

31

Fold and unfold a double layer.

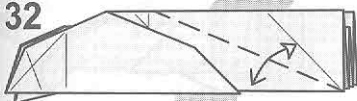

32

Fold and unfold a double layer.

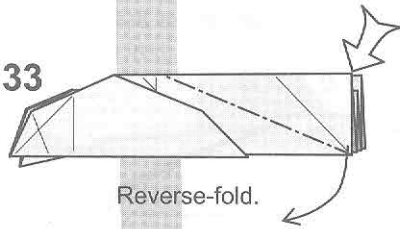

33

Reverse-fold.

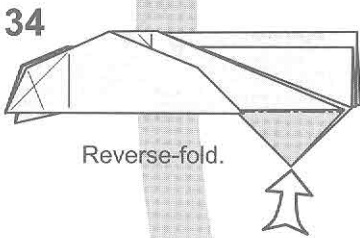

34

Reverse-fold.

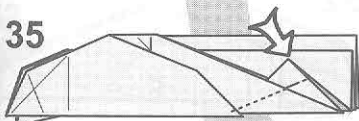

35

Reverse-fold.

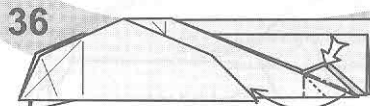

36

Squash-fold.

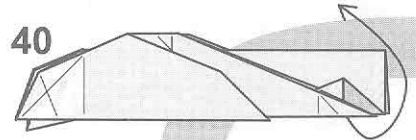

40

Open the model from the underside. The paper will not lie flat.

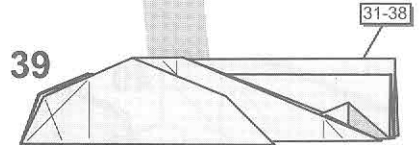

39

Repeat steps 31-38 behind.

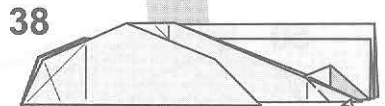

38

Fold along the underlying edge and unfold.

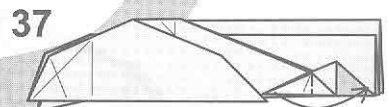

37

Fold the flap back.

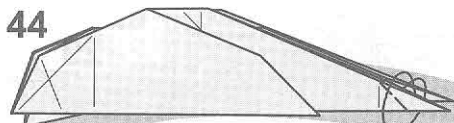

44  
Outside-reverse-fold on the existing crease.

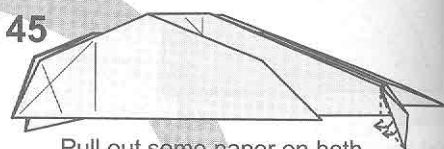

45  
Pull out some paper on both sides of the flap.

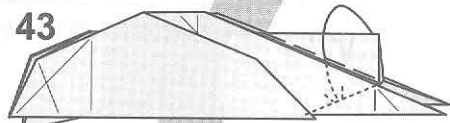

43  
Valley-fold the corner and tuck it into the shallow pocket indicated.

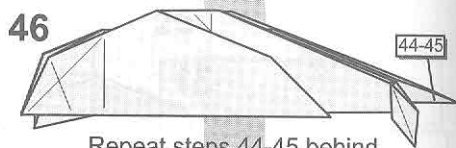

46  
Repeat steps 44-45 behind.

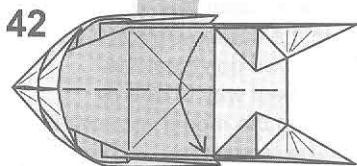

42  
Close the model back up.

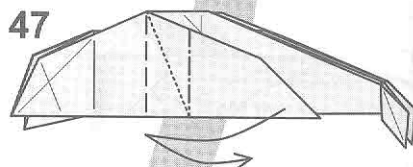

47  
Pleat the flap. The mountain fold starts at the crease at the back of the flap.

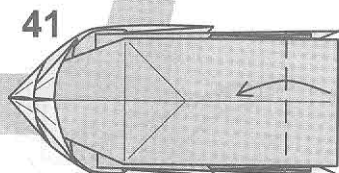

41  
Fold the edge as far as it will go.

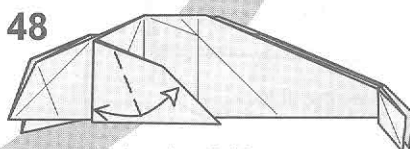

48  
Fold and unfold.

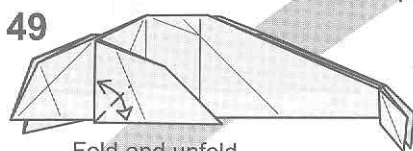

49  
Fold and unfold.

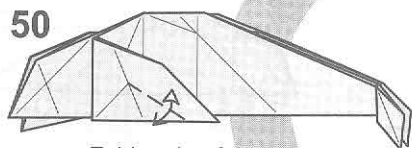

50  
Fold and unfold.

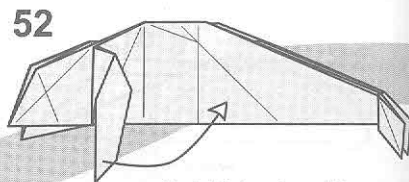

52  
Unfold to step 47.

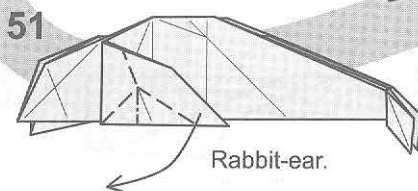

51  
Rabbit-ear.

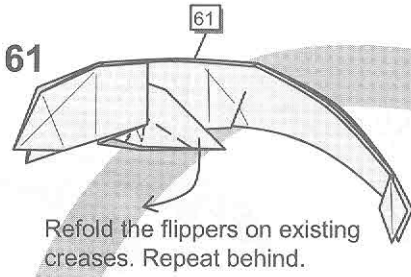

61  
Refold the flippers on existing creases. Repeat behind.

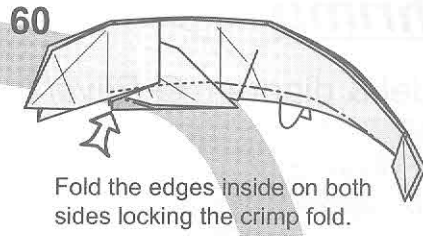

60  
Fold the edges inside on both sides locking the crimp fold.

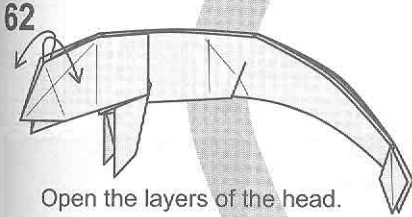

62  
Open the layers of the head.

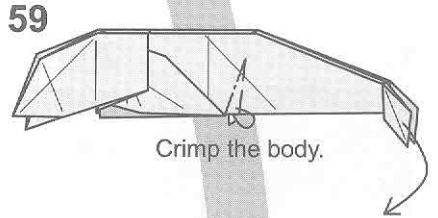

59  
Crimp the body.

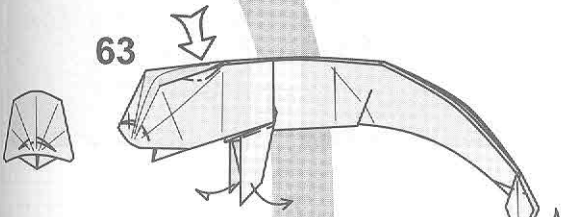

63  
Shape the neck and the nose. Fold out the tail flippers and fins. The left image shows the head seen from the front.

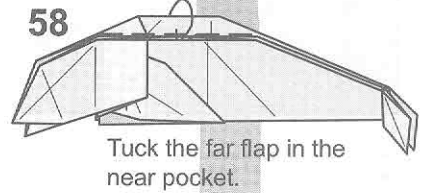

58  
Tuck the far flap in the near pocket.

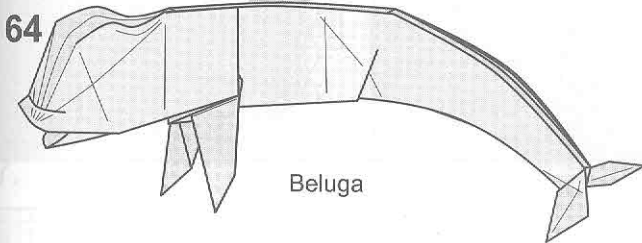

Beluga

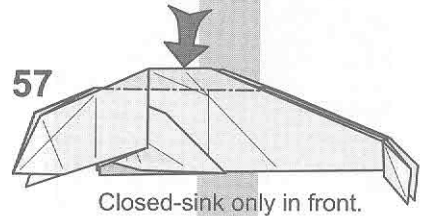

57  
Closed-sink only in front.

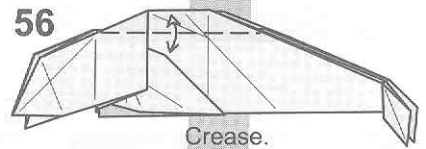

56  
Crease.

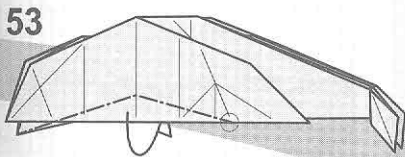

53  
Fold the edge behind. Note where this mountain fold ends. The model will not lie flat.

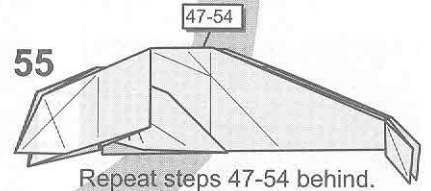

55  
Repeat steps 47-54 behind.

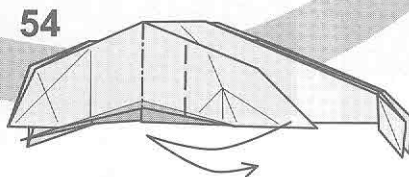

54  
Crimp-fold the flap on existing creases.

# Shrimp

Model & diagram © Pavel Nikulshin

Paper : Monocolor

Side of square : 65 cm

Density of paper : 50 g/m<sup>2</sup>

Email npvru@mail.ru

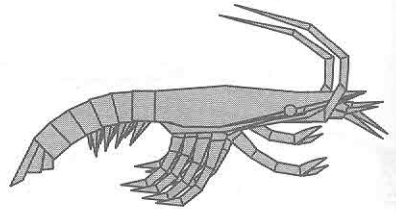

1.

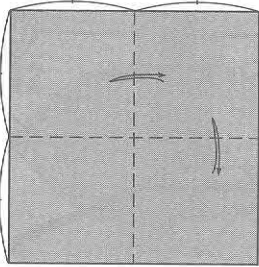

2.

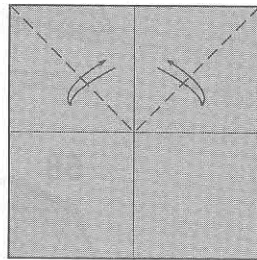

3.

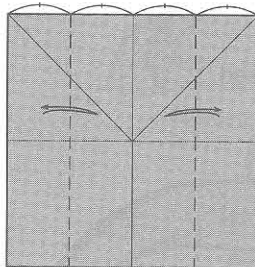

4.

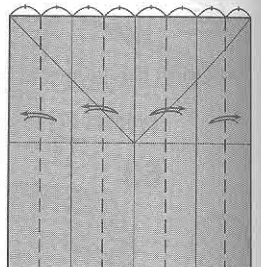

5.

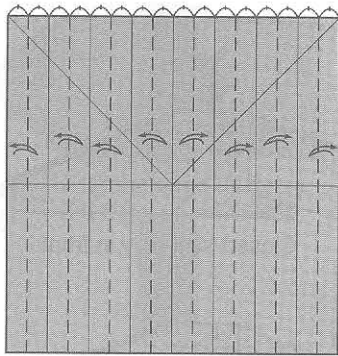

6.

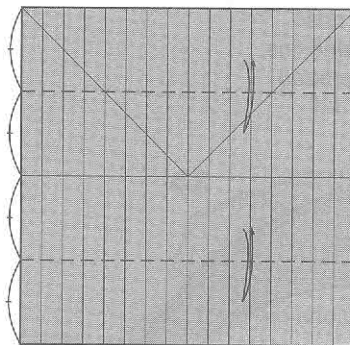

7.

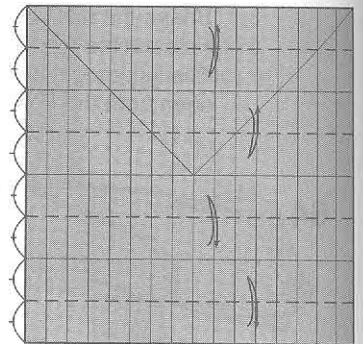

8.

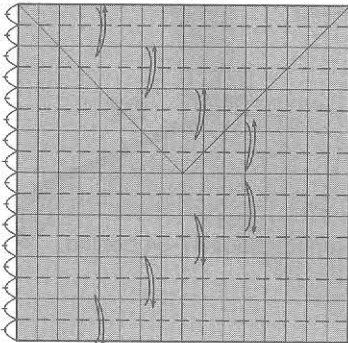

9.

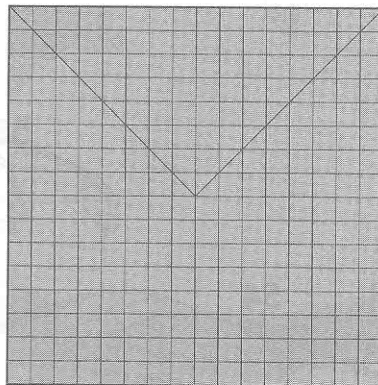

10.

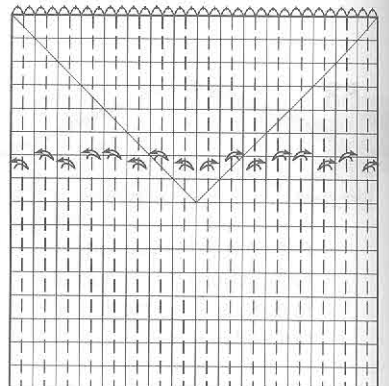

11.

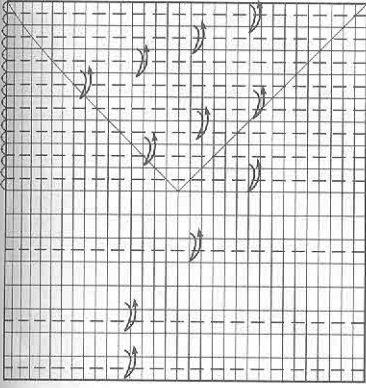

12.

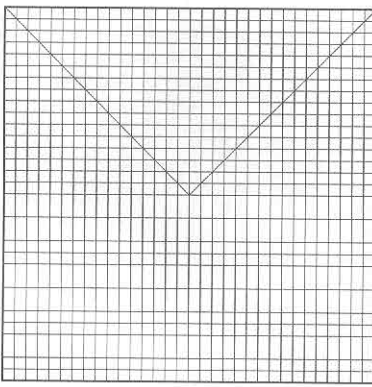

13.

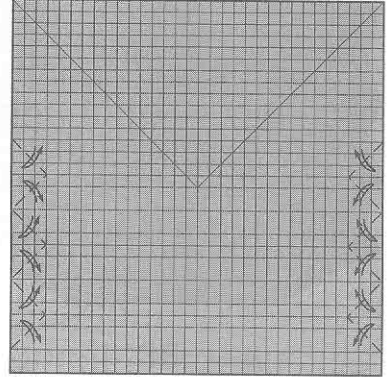

14.

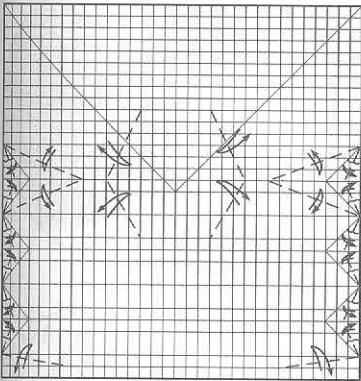

15.

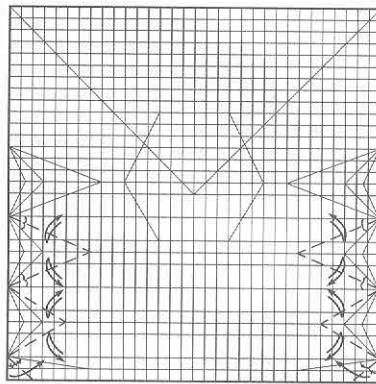

16.

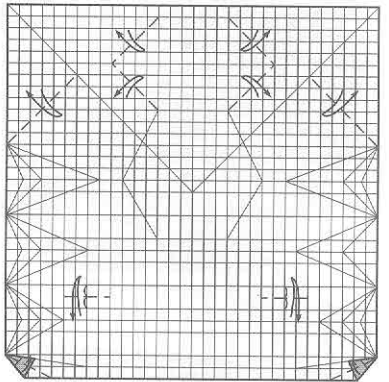

17.

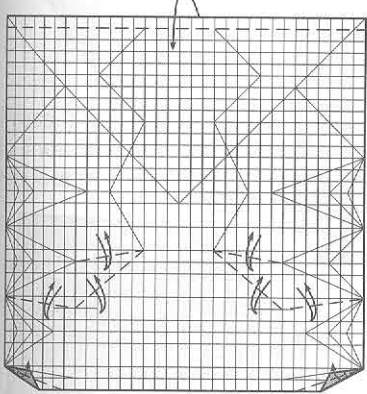

18.

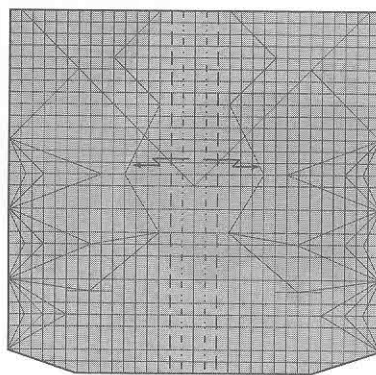

19.

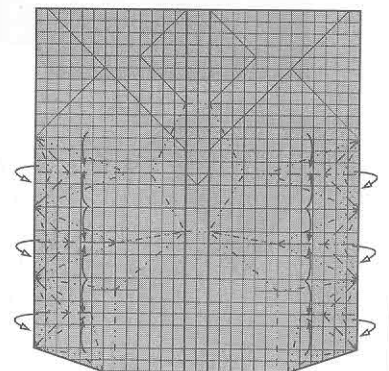

Start to fold on lines.

20.

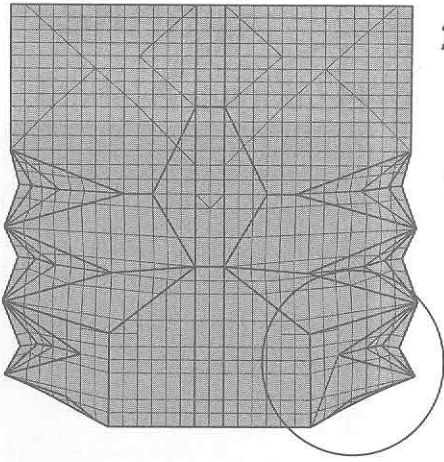

21.

Fold on lines.

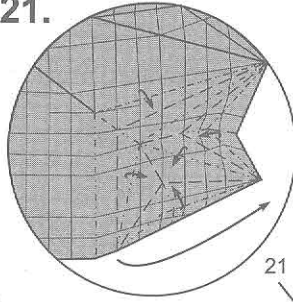

22.

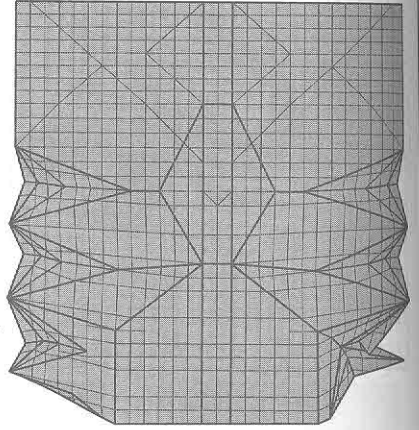

Repeat step 21.

23.

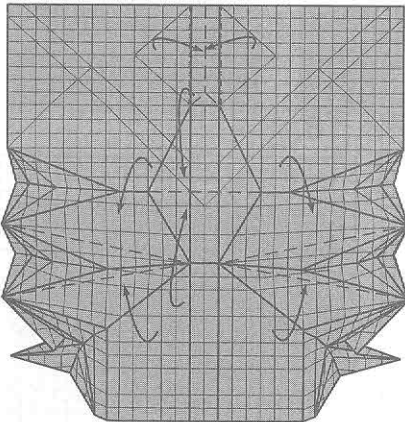

Fold on lines.

24.

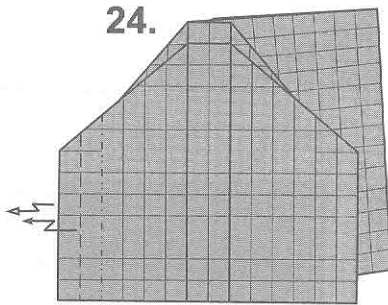

Model not plane.  
Open sink (see step 25).

25.

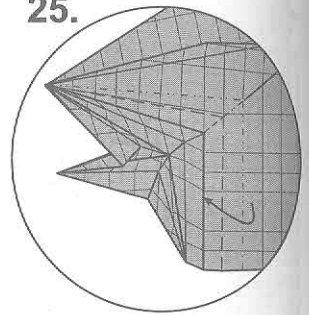

26.

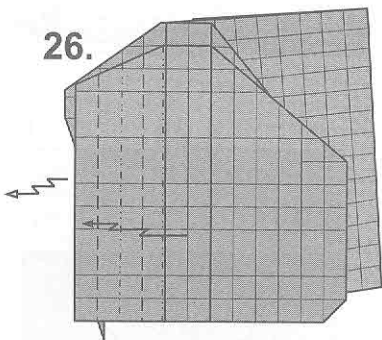

Model not plane.  
Open sink (see step 27).

Repeat steps 23-27.

28.

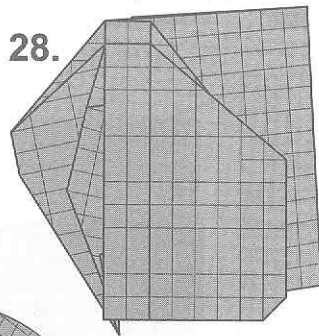

27.

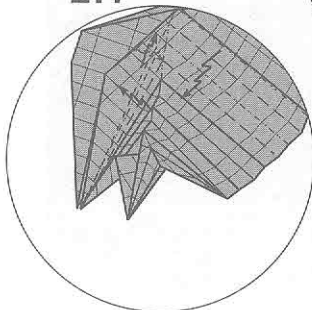

29.

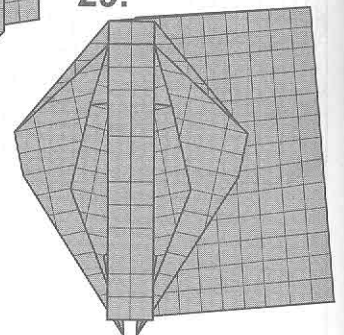

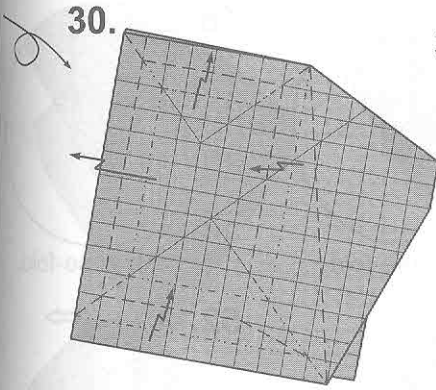

30.

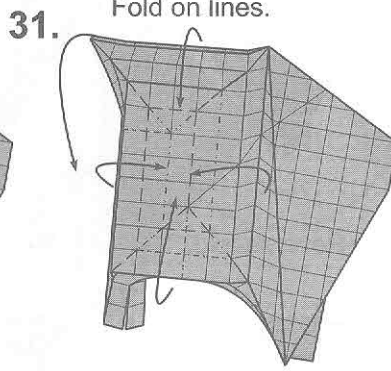

31. Fold on lines.

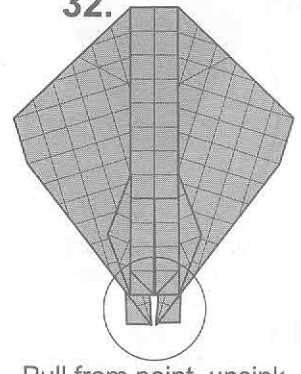

32.

Pull from point, unsink layer of paper.

Steps 30-31 to make simultaneously from both sides. Start fold on lines.

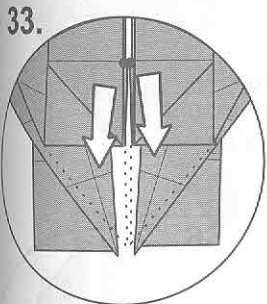

33.

Pull from points, unsink corners.

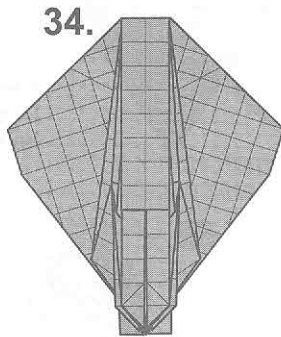

34.

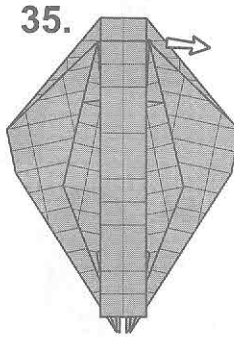

35.

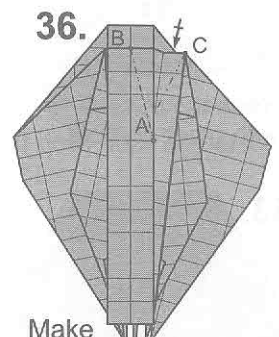

36.

Make lines AB and AC. Repeat from behind.

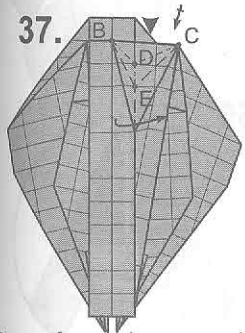

37.

Press from above, make to lines BD, DC, BE and EC. Repeat from behind.

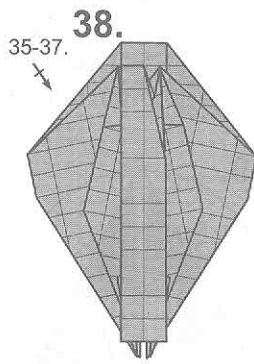

35-37.

Repeat step 35-37.

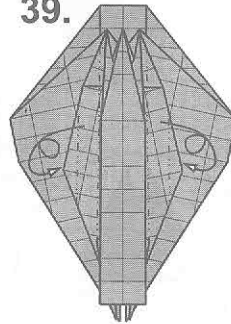

39.

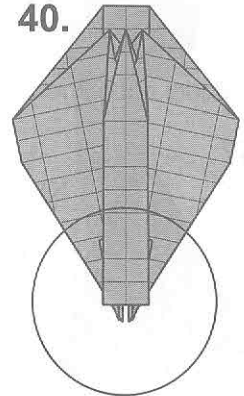

40.

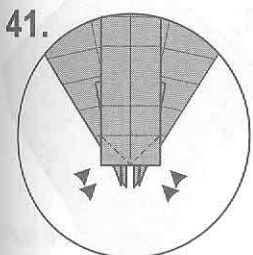

41.

Revers-fold two corners from both sides.

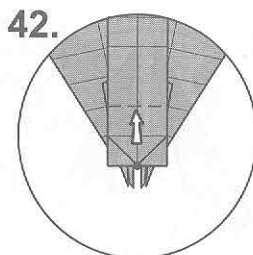

42.

Pull from point.

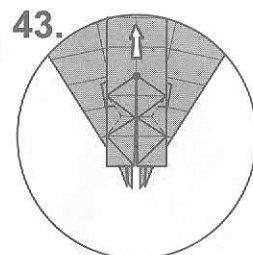

43.

Squash.

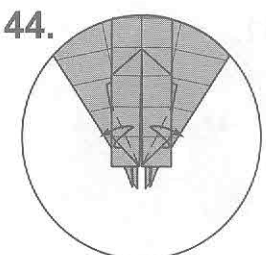

44.



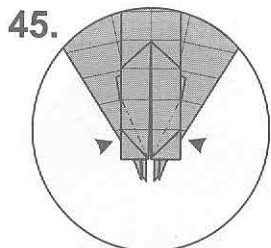

45. Sink two corners from both sides.

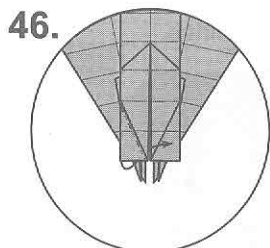

46. Reverse-fold.

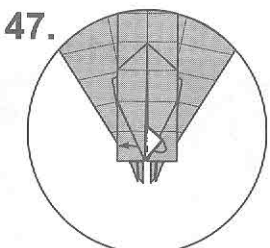

47. Reverse-fold.

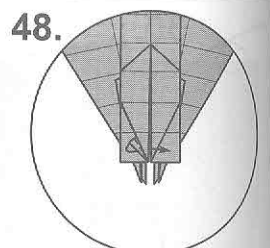

48. Reverse-fold.

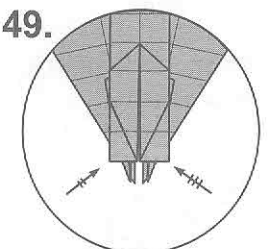

49. Repeat steps 46-48 with other corners.

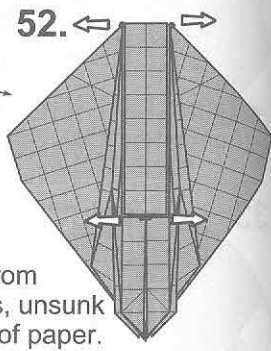
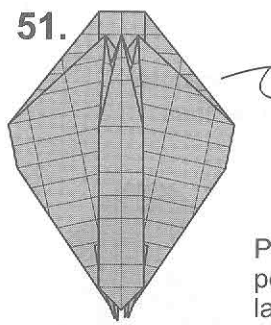
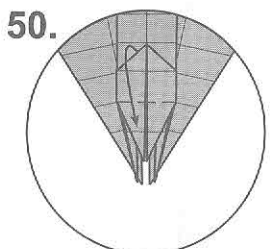

52. Pull from points, unsunk layer of paper.

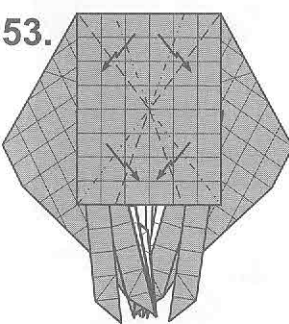

53. Model not plane.

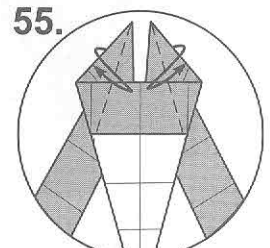
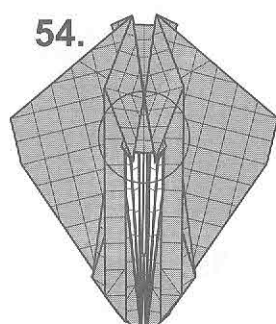

55. View from other side.

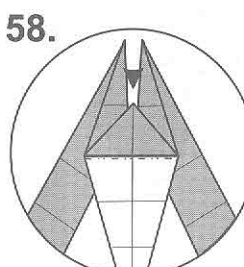
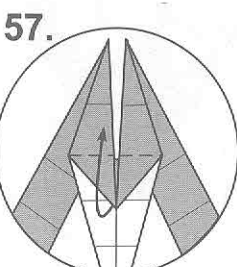
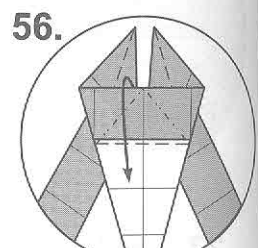

58. Sink corner.

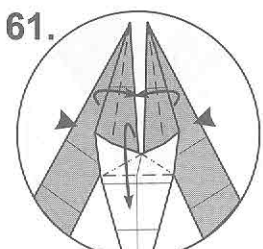
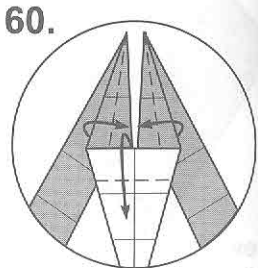
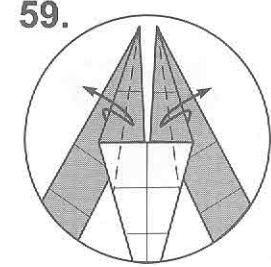

61. Press from each side, than squash.

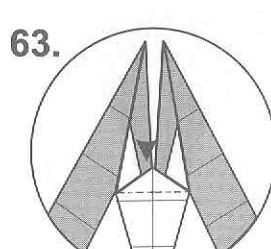
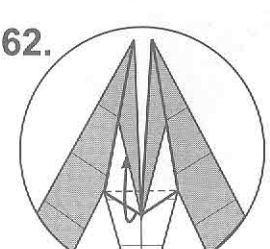

63. Sink corner.

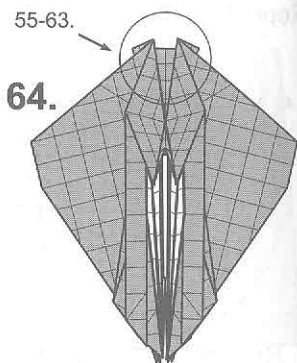

64. Repeat steps 55-63.

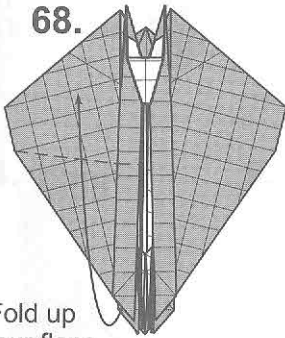
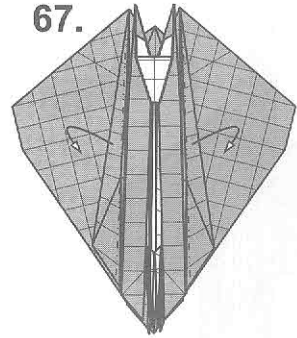
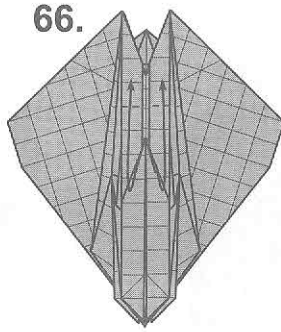
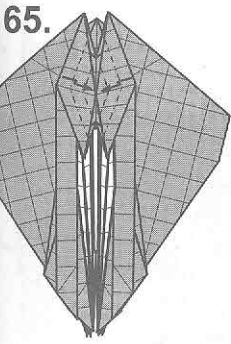

Fold up four flaps.

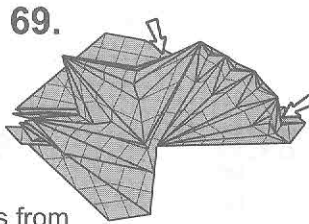

Press from each side, than squash.

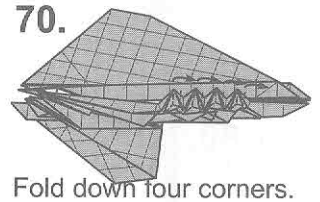

Fold down four corners.

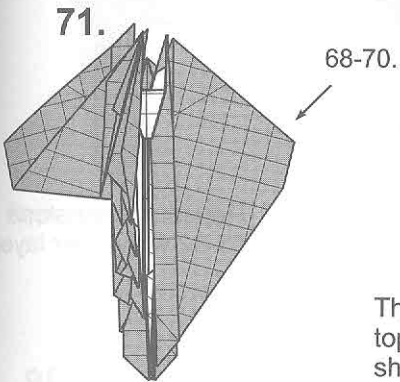

Repeat steps 68-70.

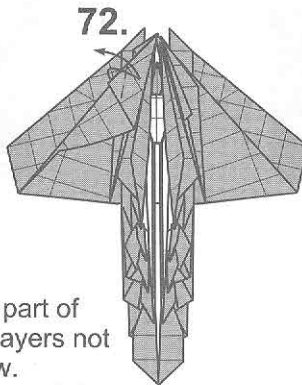

The part of top layers not show.

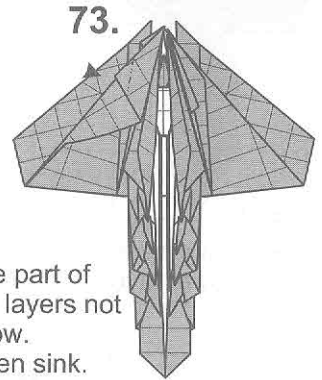

The part of top layers not show. Open sink.

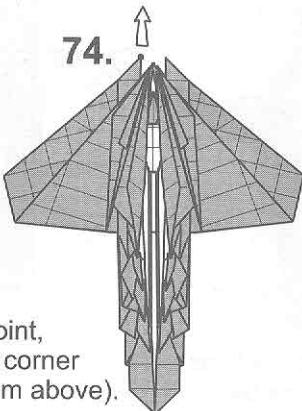

Pull from point, shift up the corner (the fifth from above).

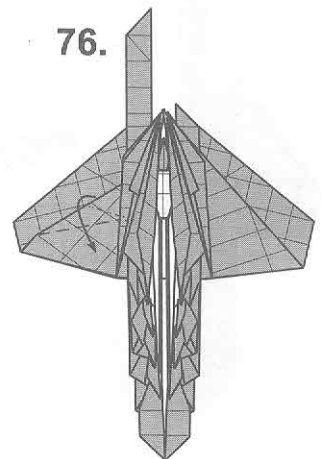
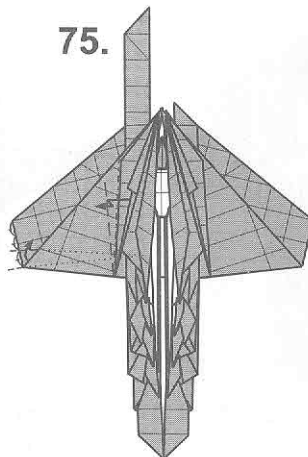

77.

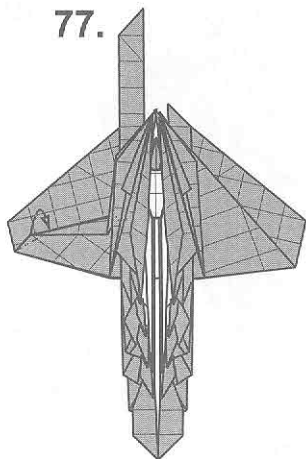

78.

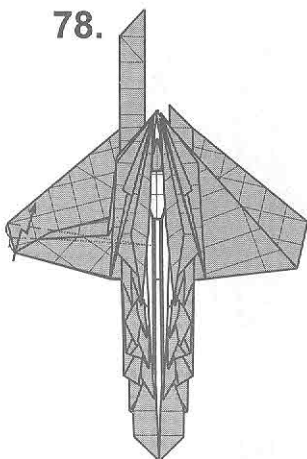

79.

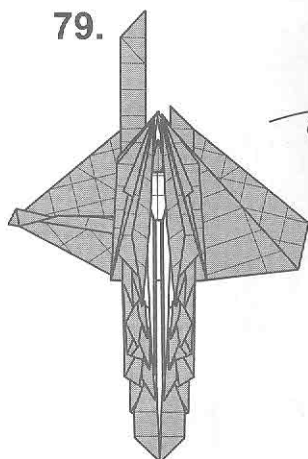

80.

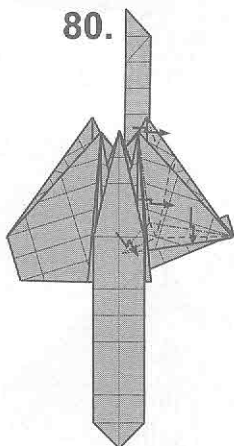

81.

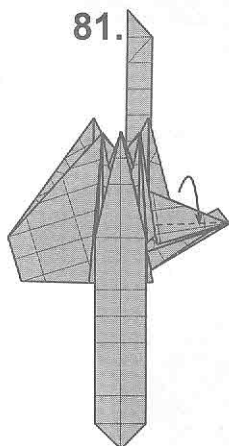

82.

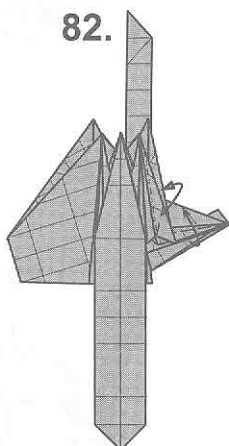

83.

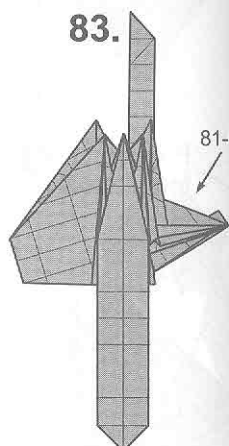

Shift top layer.  
Repeat similar step  
with lower layer.

Repeat similar steps  
81-82 with lower layer.

84.

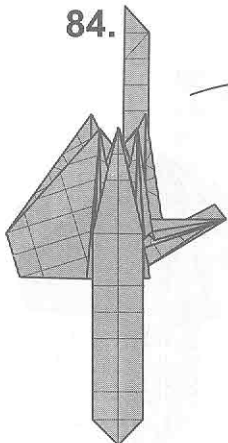

85.

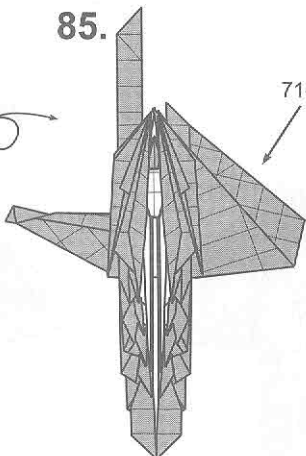

86.

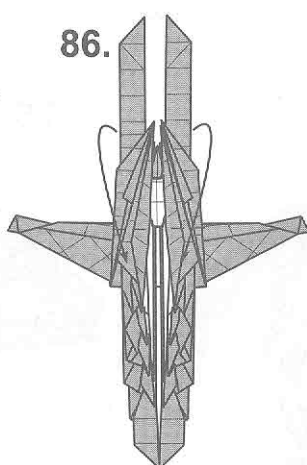

87.

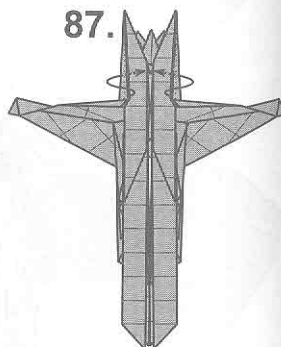

Repeat steps 71-84.

Fold down six flaps  
from both sides.

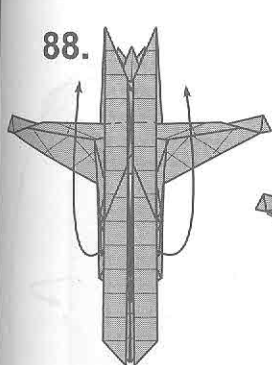

88.

Fold up two flaps from both sides.

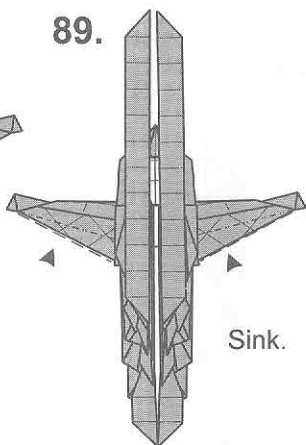

89.

Sink.

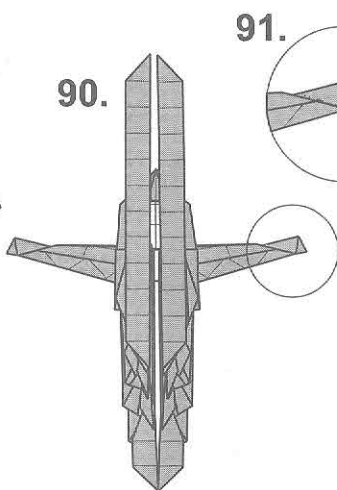

90.

91.

92.

93.

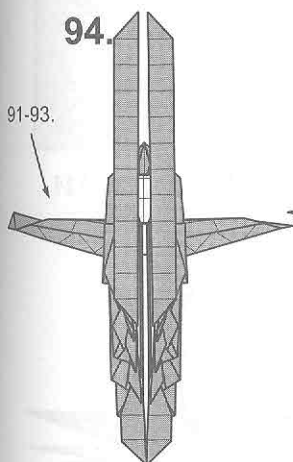

94.

91-93.

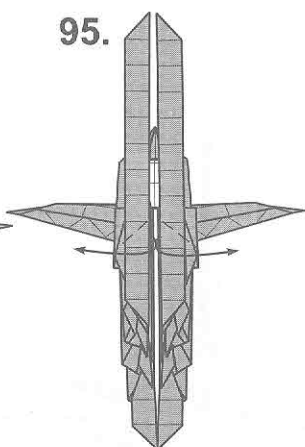

95.

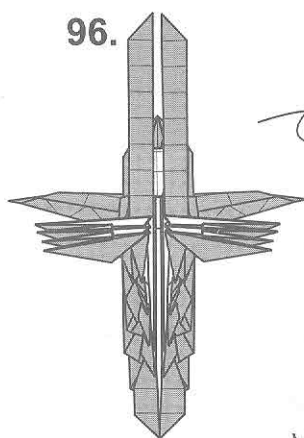

96.

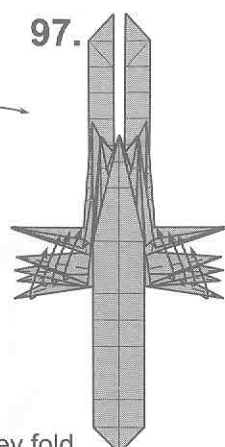

97.

Valley fold four corners from both sides.

Repeat steps 91-93.

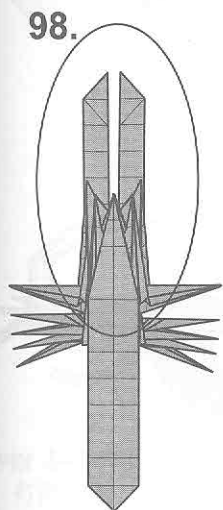

98.

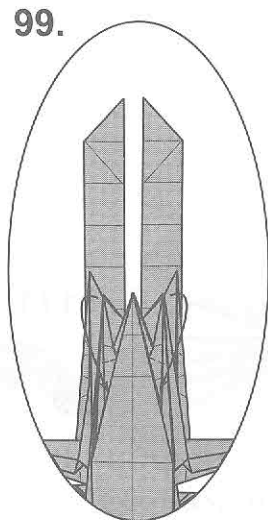

99.

Fold down corners.

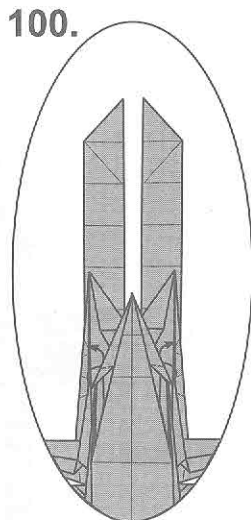

100.

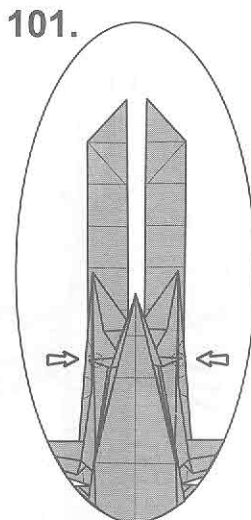

101.

Make eyes.

102.

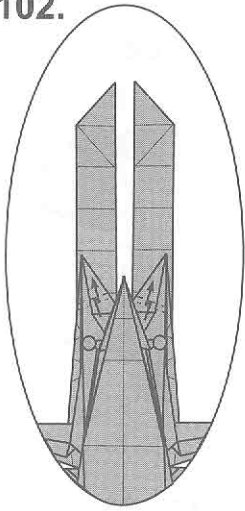

103.

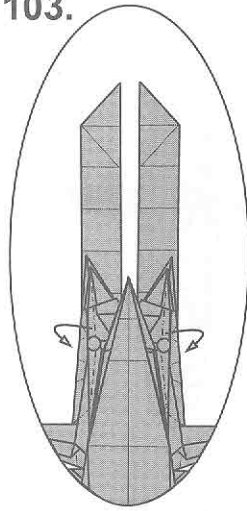

Mountain fold from both sides.

104.

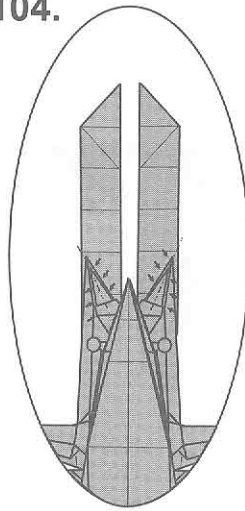

To give form antennas.

105.

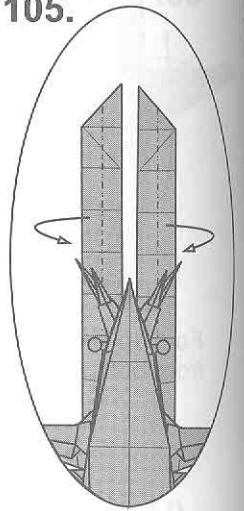

106.

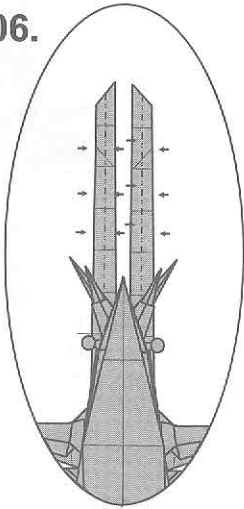

To give form antennas.

107.

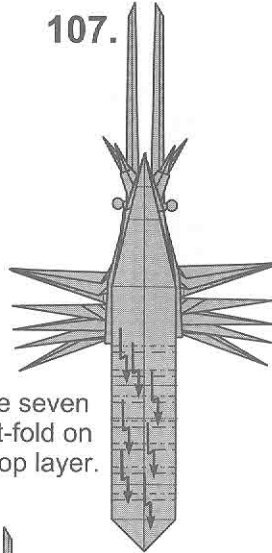

Make seven pleat-fold on the top layer.

108.

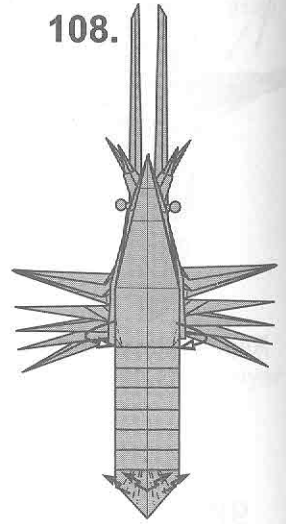

109.

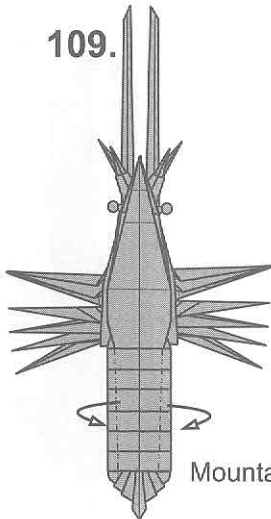

Mountain fold.

110.

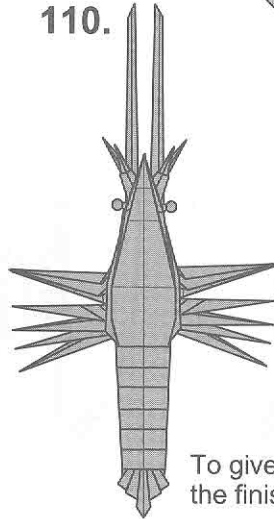

To give model the finished form.

111.

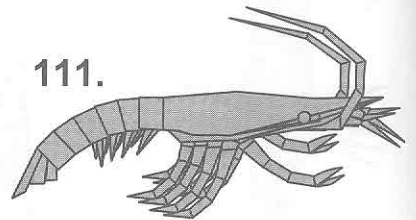

Finished.

# 大牙兔 Big Teeth Bunny

創作&圖解: 羅瑜 (阿月)

CREATOR & DIAGRAM: LO YU (ylo33) 作: 2011-01 圖: 2013-06-30

PAPER - 1 UNCUT SQUARE

THIS IS MY 3RD DIAGRAM. I DESIGNED IT WHEN I TRY TO USE THE TECHNIQUE OF FOLDING THE BABY CAT ON A SQUARE PAPER INSTEAD OF A RECTANGLE. IT IS A CARTOON RABBIT WHICH HAS A PAIR OF BIG TEETH AND LONG BIG EARS, SO I NAMED IT "BIG TEETH BUNNY". BUT MOST OF THE PEOPLE DO NOT KNOW WHAT IT WAS. IT IS NOT SO IMPORTANT, YOU KNOW IT WAS A CUTE ORIGAMI AT ALL, RIGHT? HOPE YOU WOULD LOVE IT-

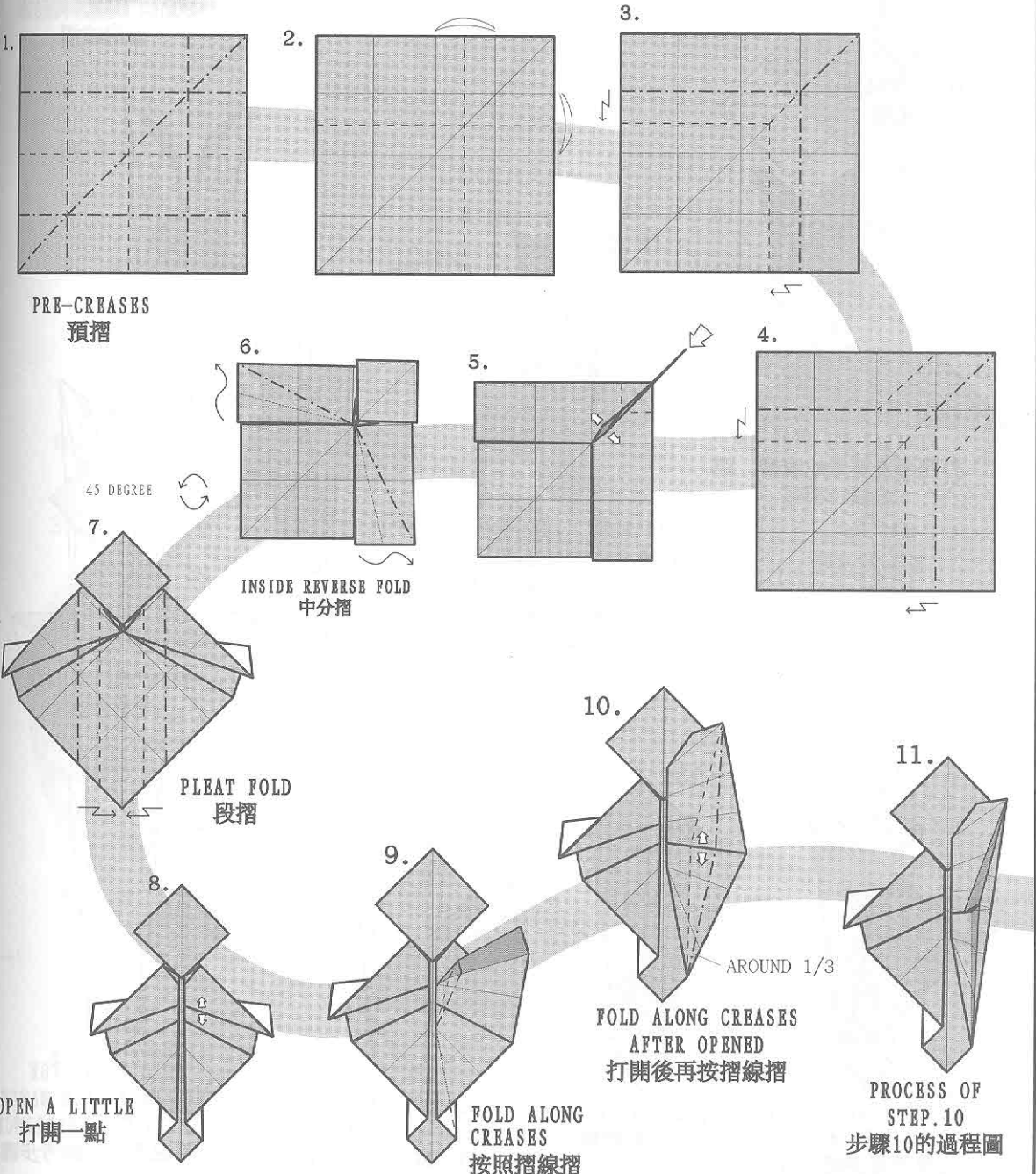
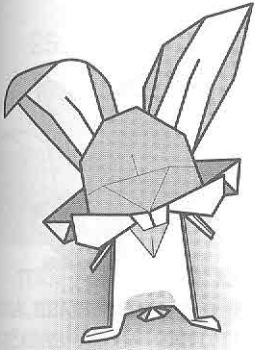

21. RABBIT EAR FOLD  
兔耳摺

22. SQUASH FOLD  
擽開壓平

23. FOLD UPWARD  
向上摺

24. PULL DOWNWARD AND FOLD ALONG CREASES  
中間向下拉，同時跟著摺線摺

20. FOLD UPWARD  
向上摺

19. PULL BOTH SIDES AGAIN, SIMILAR TO STEP. 18  
打開兩邊簡單蛇腹摺，跟步驟18相似

18. PULL BOTH SIDES AND DO SIMPLE BLOCK PLEATING, LET WATCH STEP. 19 FOR REFERENCE  
拉開兩邊作簡單蛇腹摺，請參考步驟19

17. OPEN  
向左右打開

16. TURN PAPER OVER  
把紙翻轉

15. FOLD ALONG THE CREASES, PLEASE WATCH STEP. 16 FOR REFERENCE  
按照摺線摺，可參考步驟16

14. FOLD DOWN ALONG THE CREASES  
按照摺線摺向下面

13. TURN PAPER OVER  
把紙翻轉

12. REPEAT STEP. 8 - 11 ON THE LEFT  
左邊重複步驟8-11

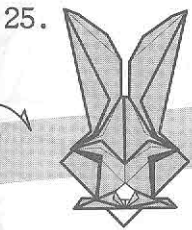

25.  
TURN PAPER OVER AND  
LET'S LOOK AT THE  
"SQUARE" IN THE FRONT  
翻轉看著"正方紙"

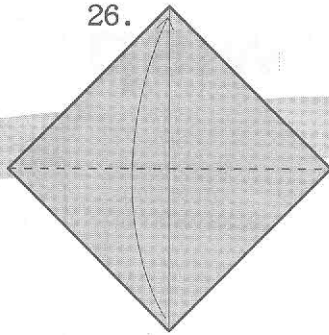

26.  
FOLD THE FRONT PAPER UPWARD  
把表面那層紙向上摺

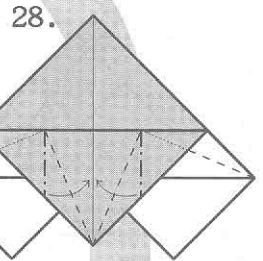
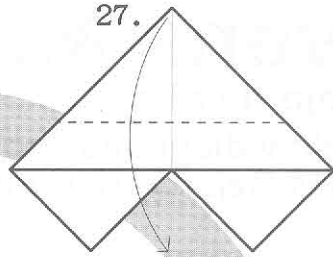

27.  
28.  
FOLD ALONG CREASES  
跟著摺線摺

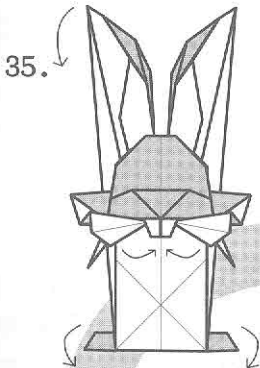

35.  
DO SOME SIMPLE SHARPING  
做些簡單的整形步驟

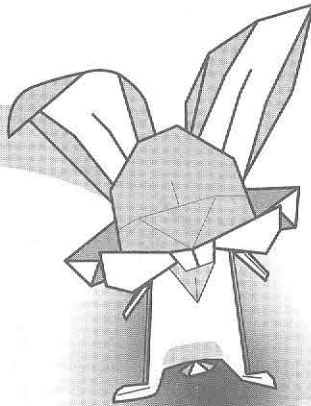

34.  
FINISHED! ENJOY IT!  
完成! 謝謝!

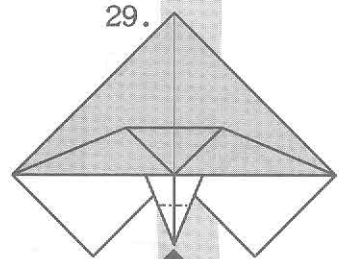

29.  
OPEN SINK  
開放式沉摺

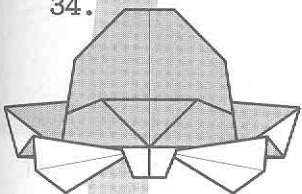

34.  
FINISHED THE FACE, GO  
BACK TO THE WHOLE MODEL  
臉部摺好, 請看回全身圖

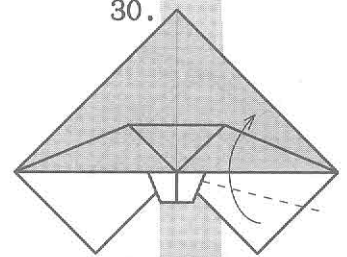

30.  
FOLD UPWARD  
向上摺

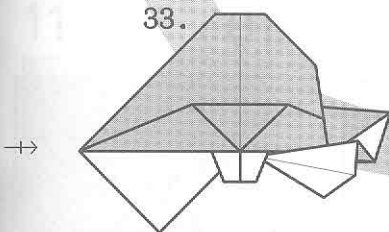

33.  
REPEAT STEP 30 - 32.  
ON THE LEFT  
左邊重複步驟30-32

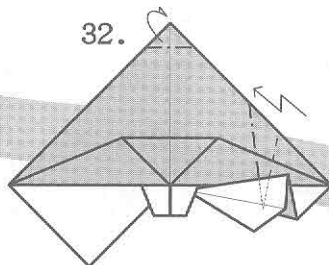

32.  
PLEAT FOLD AND MOUNTAIN  
FOLD AT THE TOP  
段摺, 上面則山摺

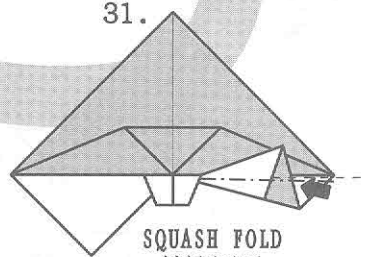

31.  
SQUASH FOLD  
撐開壓平



# Nivens Mc Twisp

## Conejo de alicia

Modelo y diagramas por  
Nicolás Gajardo Henríquez

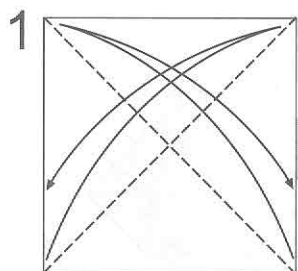
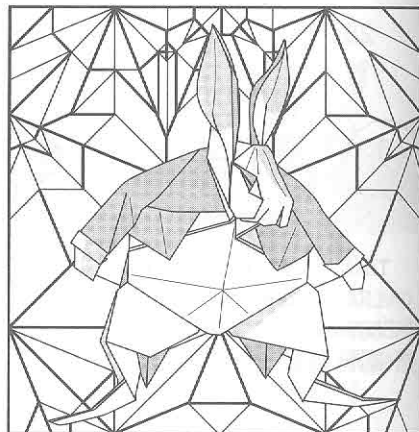

1 Plegar y desplegar las diagonales.

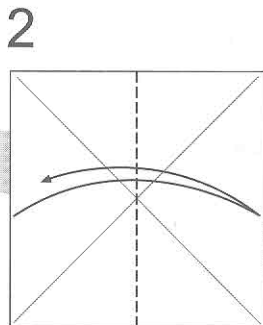

2 Plegar y desplegar la mediatriz.

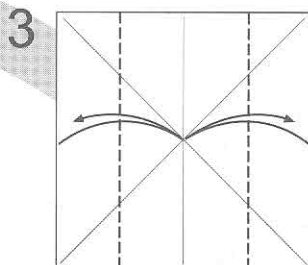

3 Plegar y desplegar a razón de 1/4.

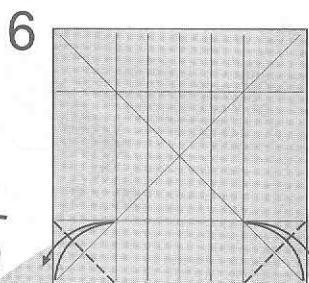

6 Plegar y desplegar

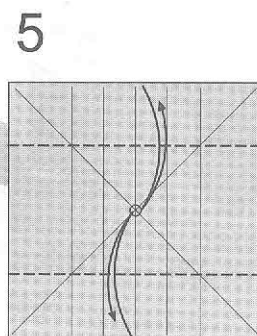

5 Plegar y desplegar hasta la referencia.

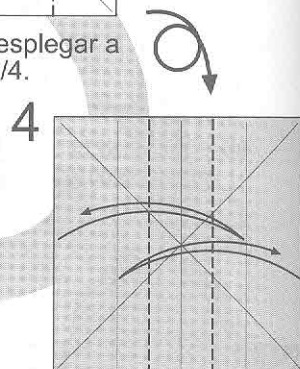

4 Plegar y desplegar.

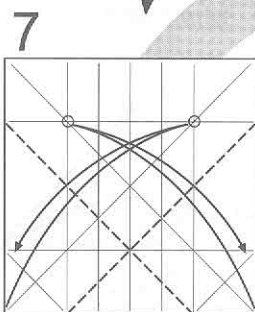

7 Plegar y desplegar utilizando las referencias.

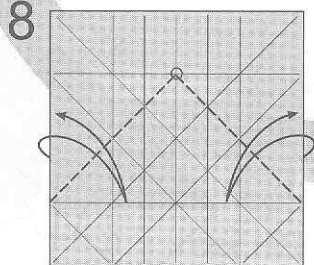

8 Plegar y desplegar hasta el cruce referenciado.

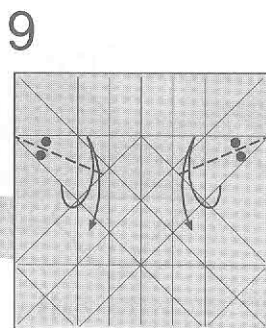

9 Plegar y desplegar los ángulos bisectores.

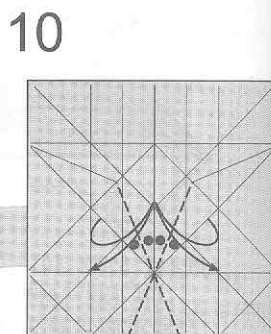

10 Plegar y desplegar los ángulos bisectores.

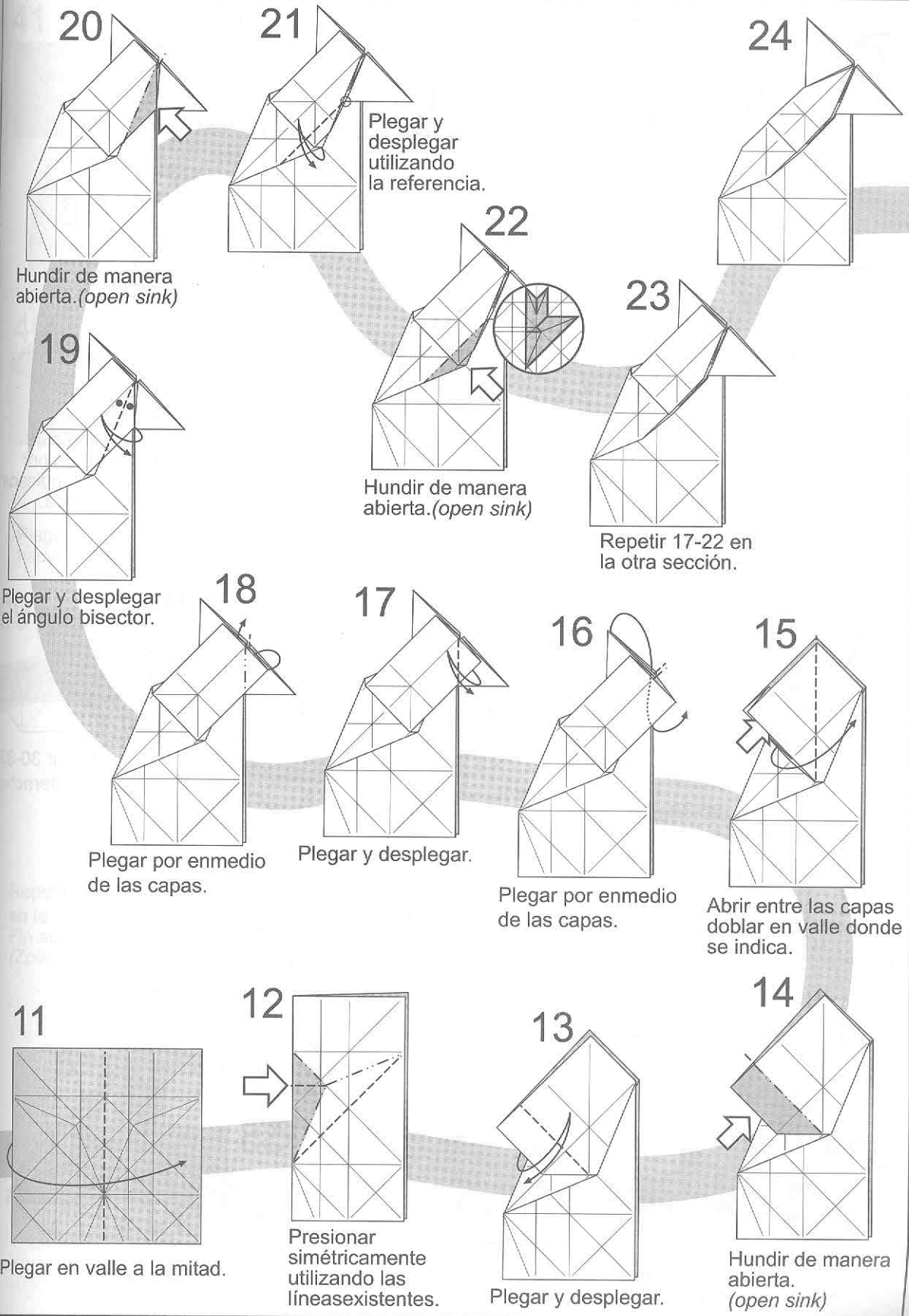

20

Hundir de manera abierta. (open sink)

21

Plegar y desplegar utilizando la referencia.

24

19

Plegar y desplegar el ángulo bisector.

22

Hundir de manera abierta. (open sink)

23

Repetir 17-22 en la otra sección.

18

Plegar por enmedio de las capas.

17

Plegar y desplegar.

16

Plegar por enmedio de las capas.

15

Abrir entre las capas doblar en valle donde se indica.

11

Plegar en valle a la mitad.

12

Presionar simétricamente utilizando las líneas existentes.

13

Plegar y desplegar.

14

Hundir de manera abierta. (open sink)

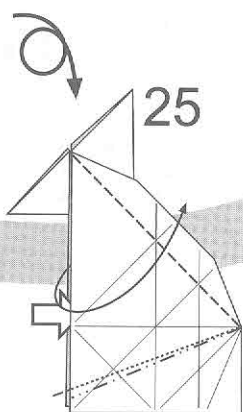

25  
Abrir y aplastar simétricamente.

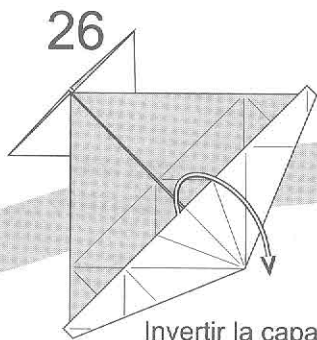

26  
Invertir la capa.

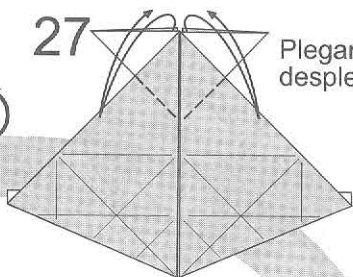

27  
Plegar y desplegar.

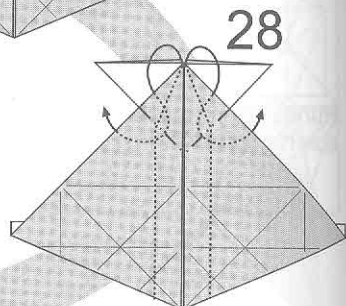

28  
Plegar por enmedio de las capas, pasando por detrás de la capa indicada en la línea punteada.

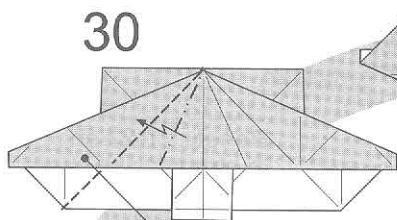

30  
Plegar hacia arriba.

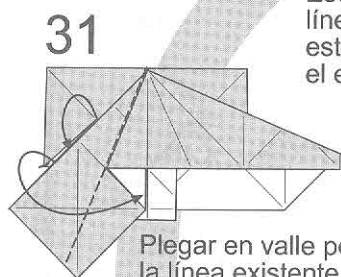

31  
Plegar en valle por la línea existente y acomodar la capa trasera.

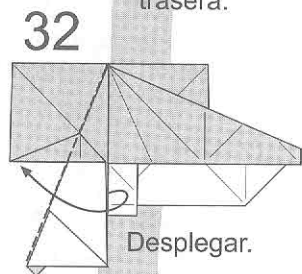

32  
Desplegar.

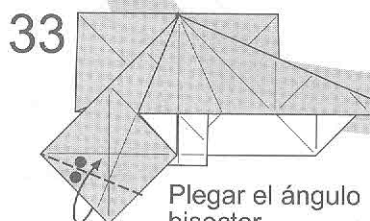

33  
Plegar el ángulo bisector.

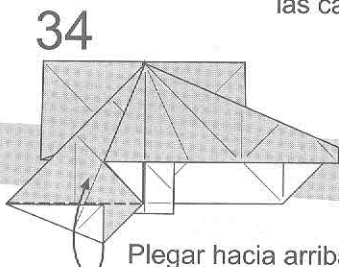

34  
Plegar hacia arriba.

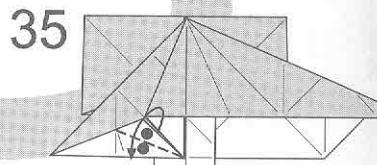

35  
Plegar el ángulo bisector.

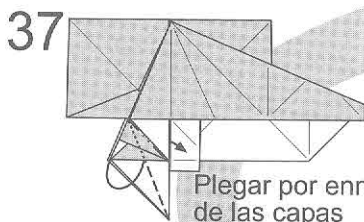

37  
Plegar por enmedio de las capas

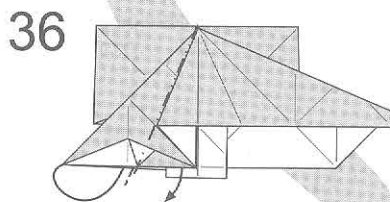

36  
Plegar por enmedio de las capas.

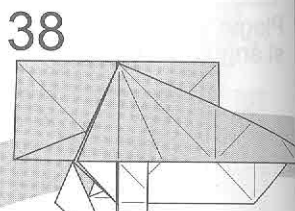

38  
Repetir 30-37 en la derecha.

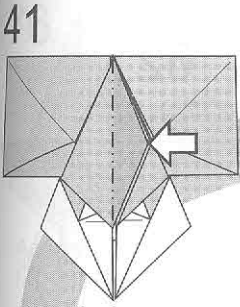

Hundir de manera cerrada.  
(Closed sink)

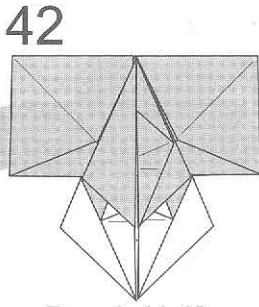

Repetir 41-42 en la derecha.

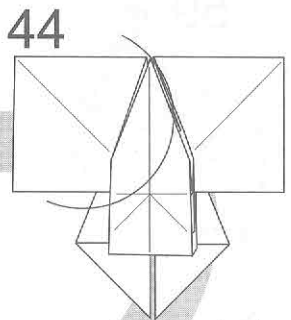
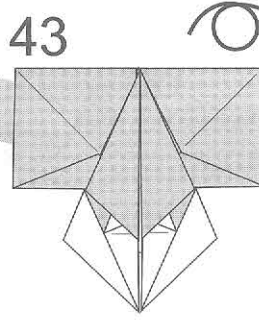

Acercamiento (Zoom in)

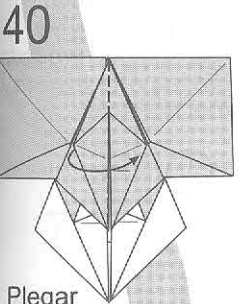

Plegar hacia la derecha.

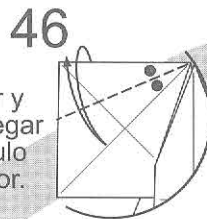

Plegar y desplegar el ángulo bisector.

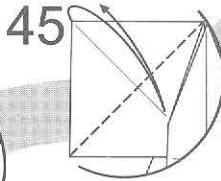

Plegar y desplegar.

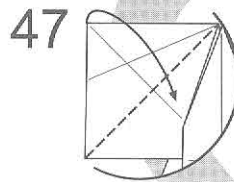

Plegar por la línea existente.

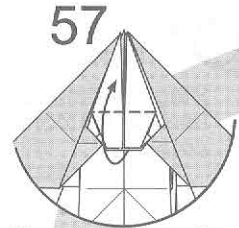

Plegar hacia arriba. Fin acercamiento. (Zoom out)

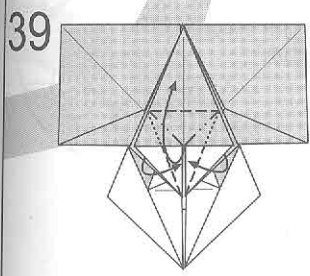

Repetir 44-50 en la derecha. Fin acercamiento. (Zoom out)

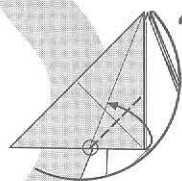

Plegar en 45° usando la referencia.

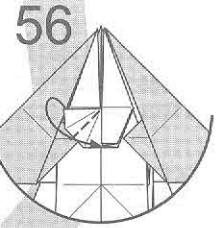

Plegar hacia abajo. Repetir 55-56 en la derecha.



Plegar hacia atrás.

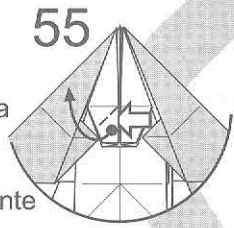

Abrir hacia la izquierda estirando completamente la capa.

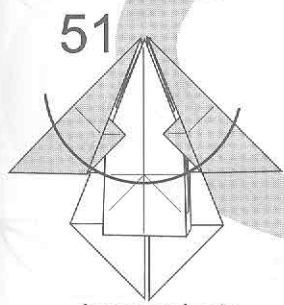

Acercamiento. (Zoom in)

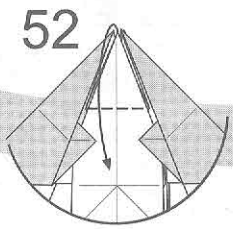

Plegar hacia abajo.

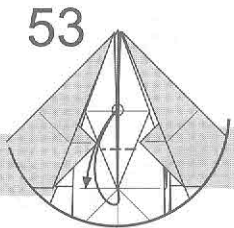

Plegar y desplegar hasta la referencia.



Hundir de manera abierta. (Open sink)

59

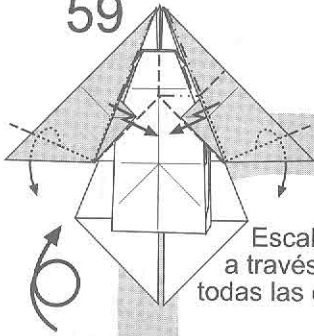

Escalonar a través de todas las capas.

60

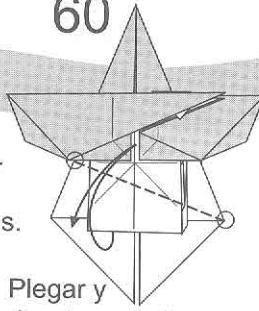

Plegar y desplegar uniendo las referencias.

61

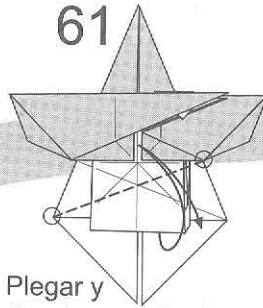

Plegar y desplegar uniendo las referencias.

62

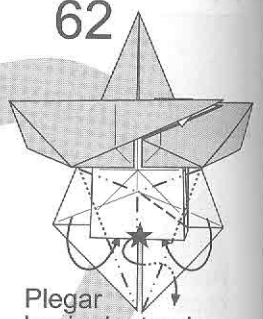

Plegar hacia dentro, la ★ debe pasar por enmedio de las solapas y quedar en la parte trasera del modelo.

58

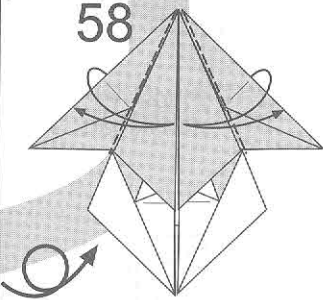

Plegar y desplegar usando los bordes creados.

63

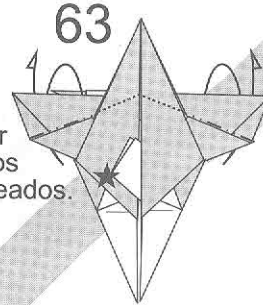

Plegar y desplegar usando los bordes creados.

64

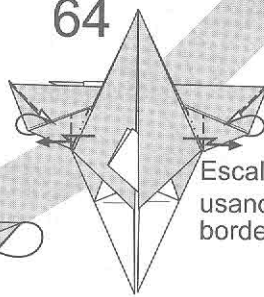

Escalonar usando los bordes.

65

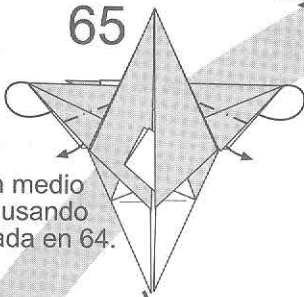

Plegar por en medio de las capas usando la marca creada en 64.

73

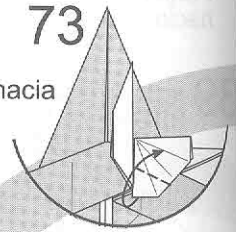

Plegar hacia arriba.

72

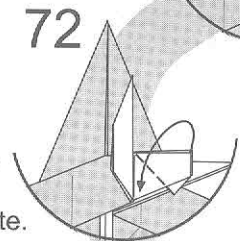

Plegar hacia abajo por la línea existente.

66

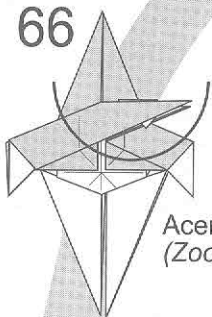

Acercamiento. (Zoom in)

71



Hundir de manera abierta a través de todas las capas. (Open sink)

67



Plegar hacia la izquierda la primera aleta.

68

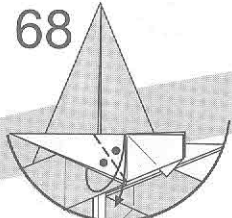

Plegar y desplegar el ángulo bisector.

69

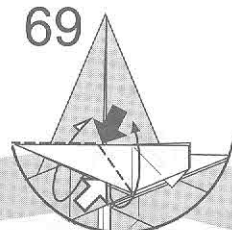

Abrir por abajo, dejando 2 capas a cada lado, para luego presionar levemente arriba para invertir los pliegues.

70

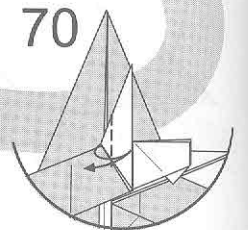

Plegar y desplegar.

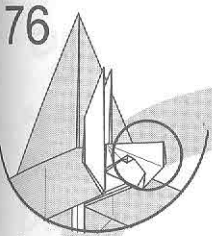

76 Acercamiento.  
(Zoom in)

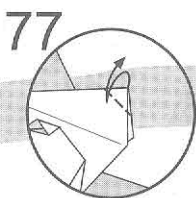

77 Plegar y  
desplegar.

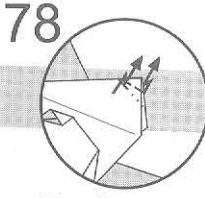

78 Escalonar  
simétricamente.

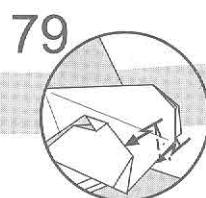

79 Escalonar en  
ambos lados.

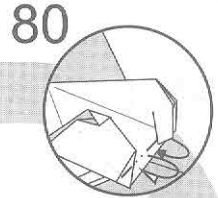

80 Plegar hacia dentro.  
Fin acercamiento.  
(Zoom out)



75 Repetir 67-75 en  
el otro lado.

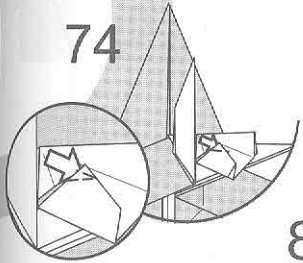

74

Abrir y aplastar.

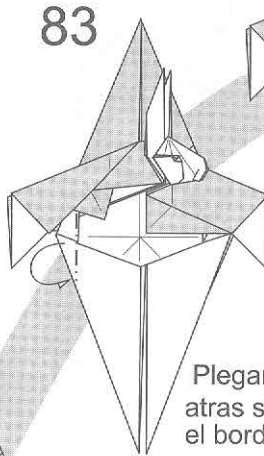

83

Plegar hacia  
atras siguiendo  
el borde.

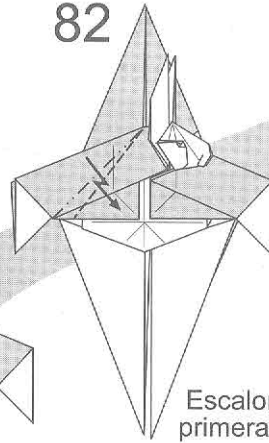

82

Escalonar las  
primeras capas.

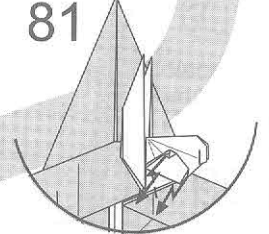

81

Escalonar en  
ángulo para  
reacomodar.

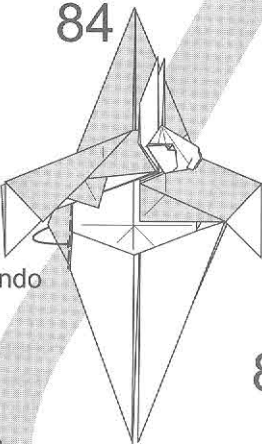

84

Plegar hacia  
dentro siguiendo  
el borde.

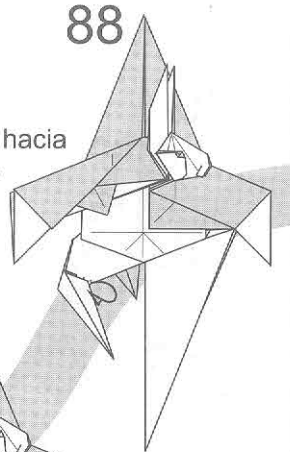

88

Plegar hacia  
dentro.

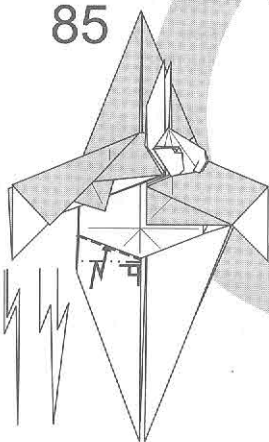

85

Escalonar a través  
de todas las capas.  
Separar las capas  
escalonadas.

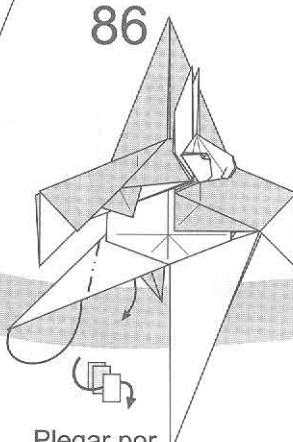

86

Plegar por  
enmedio de las capas,  
dejando 2 atrás y solo  
una adelante.

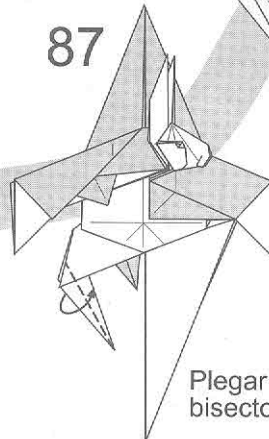

87

Plegar el ángulo  
bisector.

98

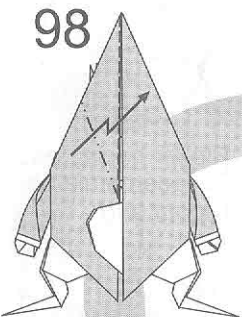

Escalonar para dar volumen.

97

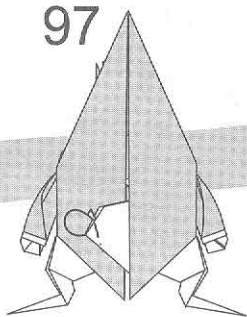

Plegar hacia dentro.

96

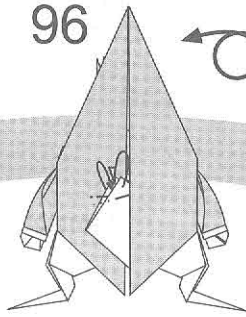

Plegar hacia dentro.

95

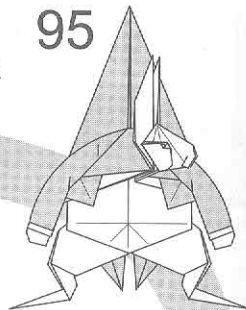

94

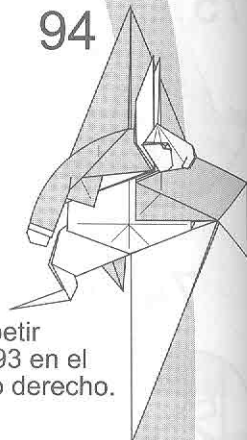

Repetir 82-93 en el lado derecho.

99

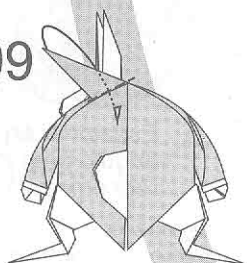

Plegar hacia dentro la aleta sobrante.

102

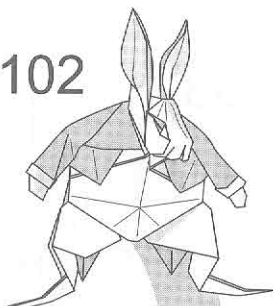

Modelo terminado.

100

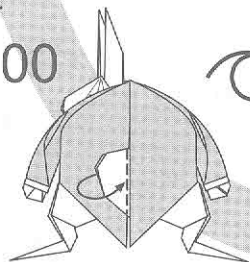

101

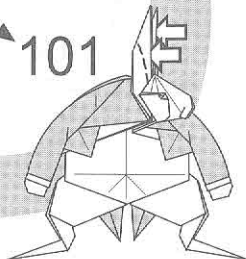

Abrir entre las capas.

93

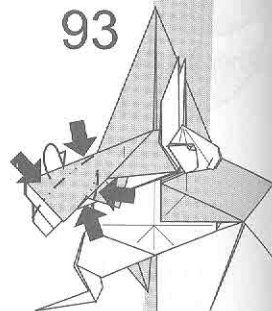

Plegar hacia atrás y dar volumen.

89

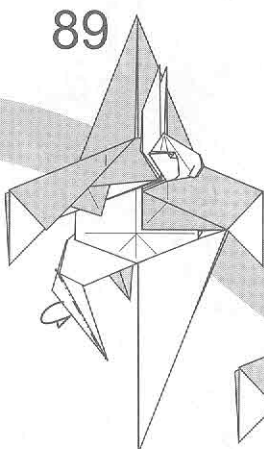

Repetir 88-89 atrás arrastrando las 2 capas.

90

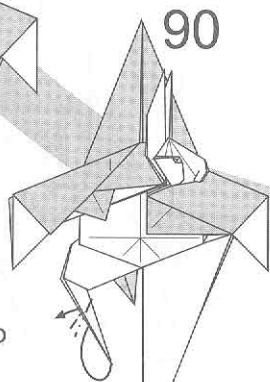

Plegar por enmedio de las capas.

91

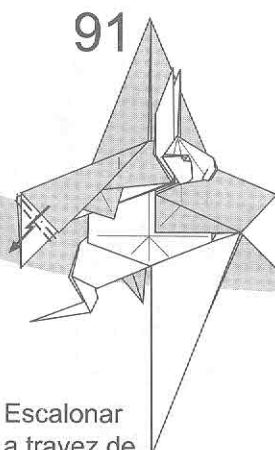

Escalonar a travez de todas las capas.

92

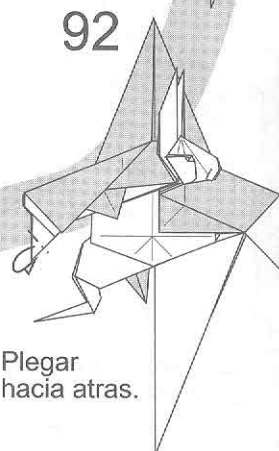

Plegar hacia atrás.

# 양 (Sheep)

창작 : 정기담

Design : JEONG ki-dam

Date : 2013/02/06

다이어그램 : 김세익

Diagrams : Se-ik KIM

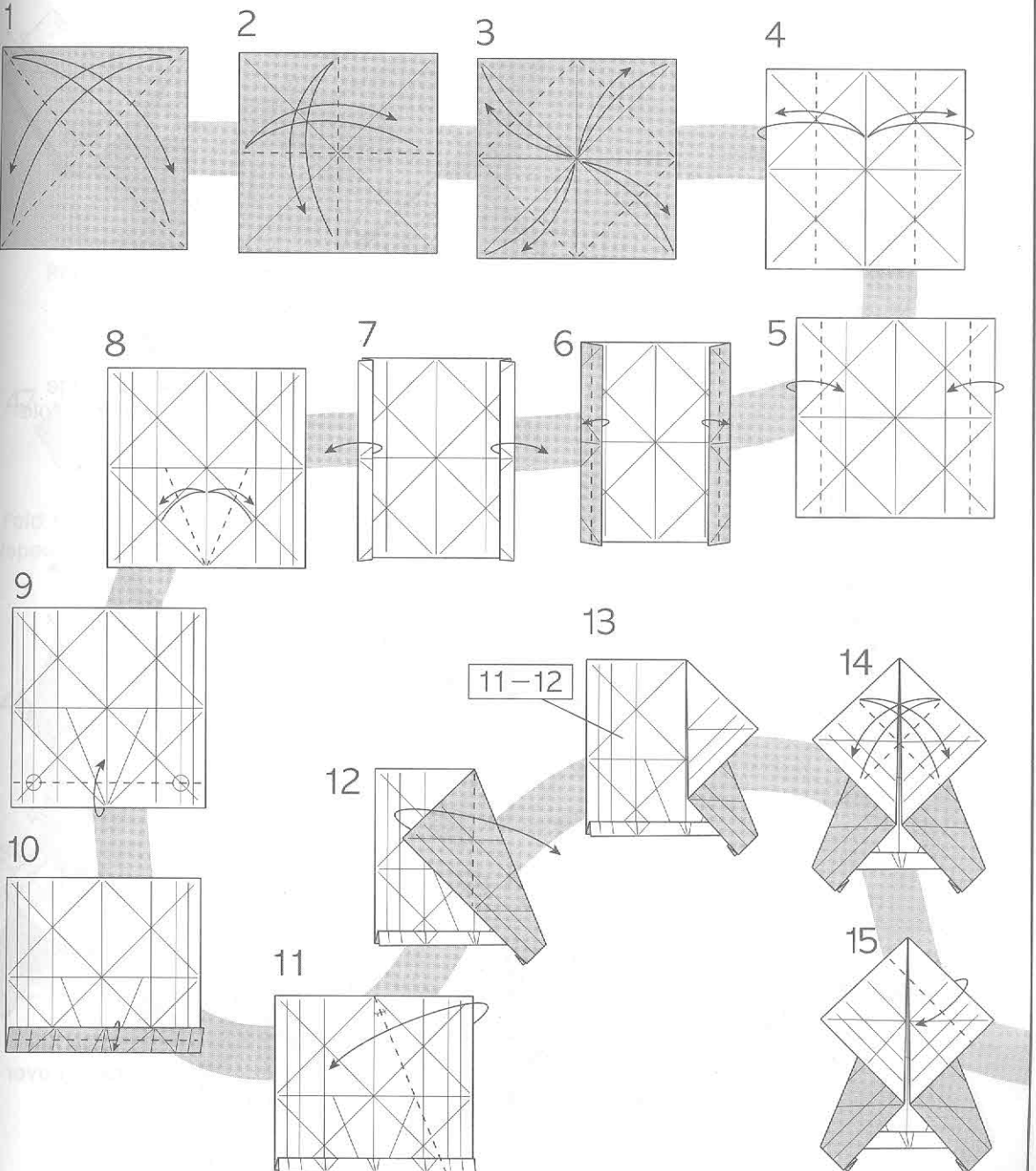
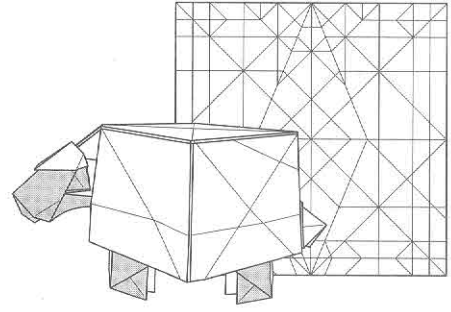



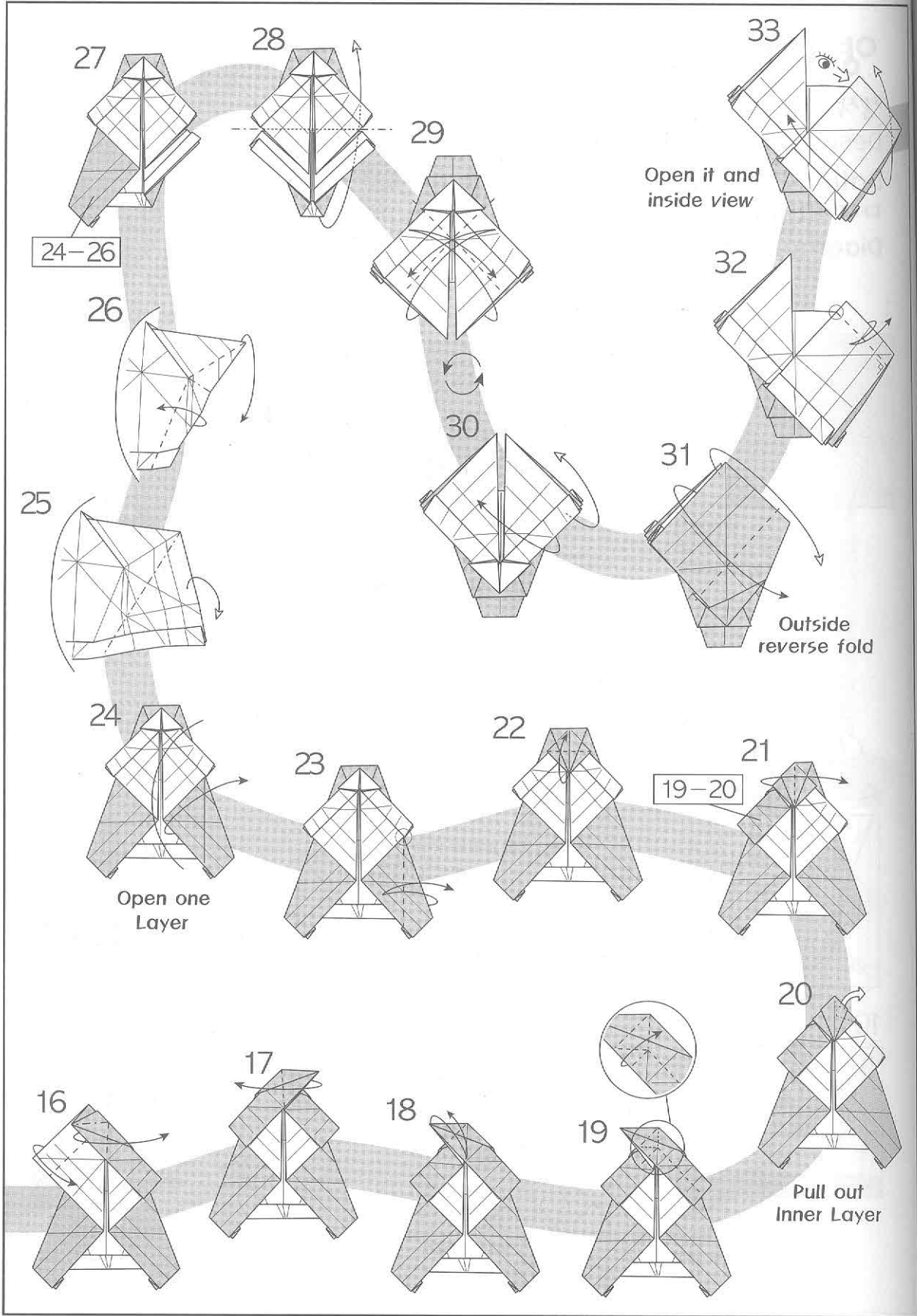

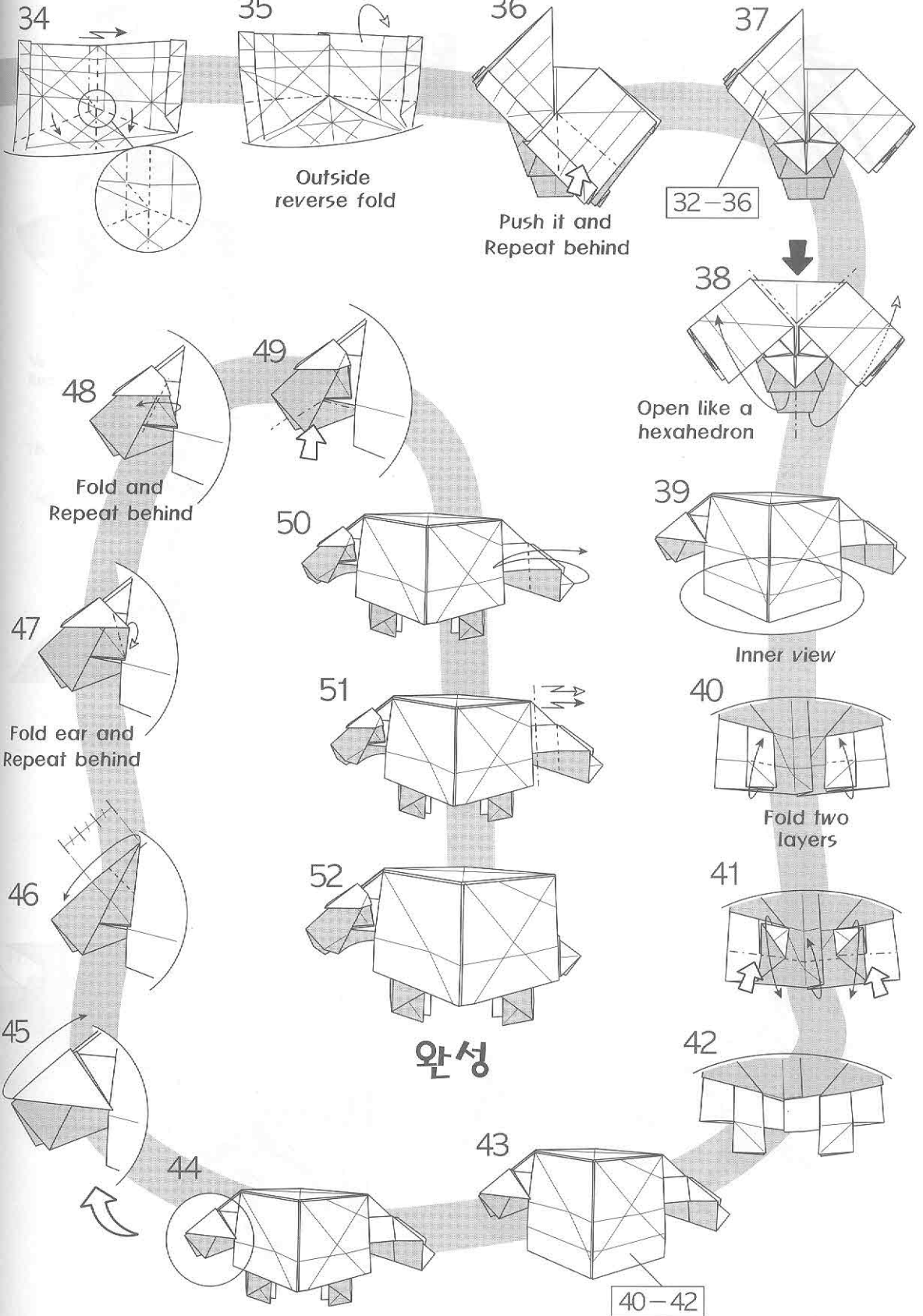

완성

40-42

鹿

Deer  
Design & diagram by  
Fabiana Sanapanya

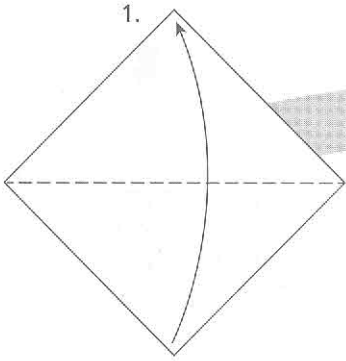
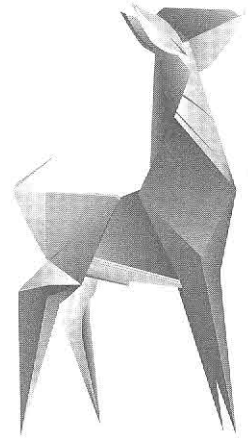
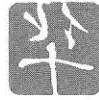

1.

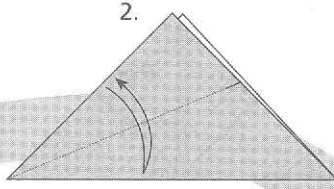

2.

Make a pinch along the edge.

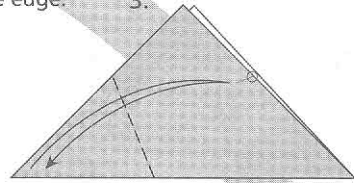

3.

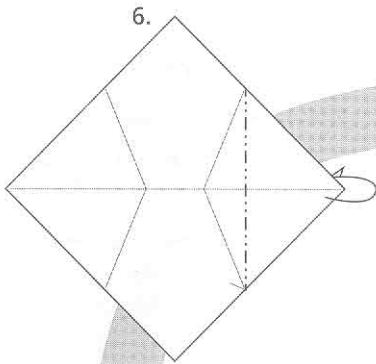

6.

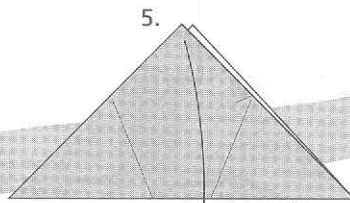

5.

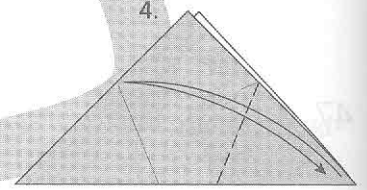

4.

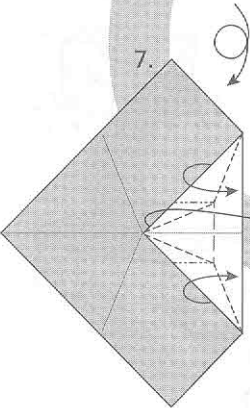

7.

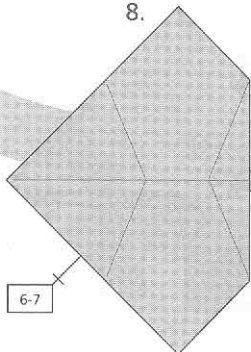

8.

6-7

Repeat steps 6-7.

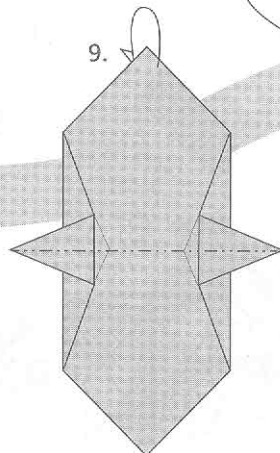

9.

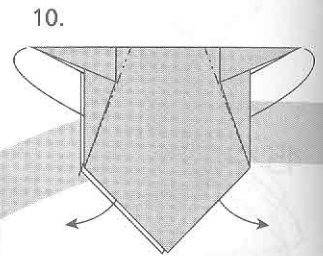

10.

Inside reverse fold.

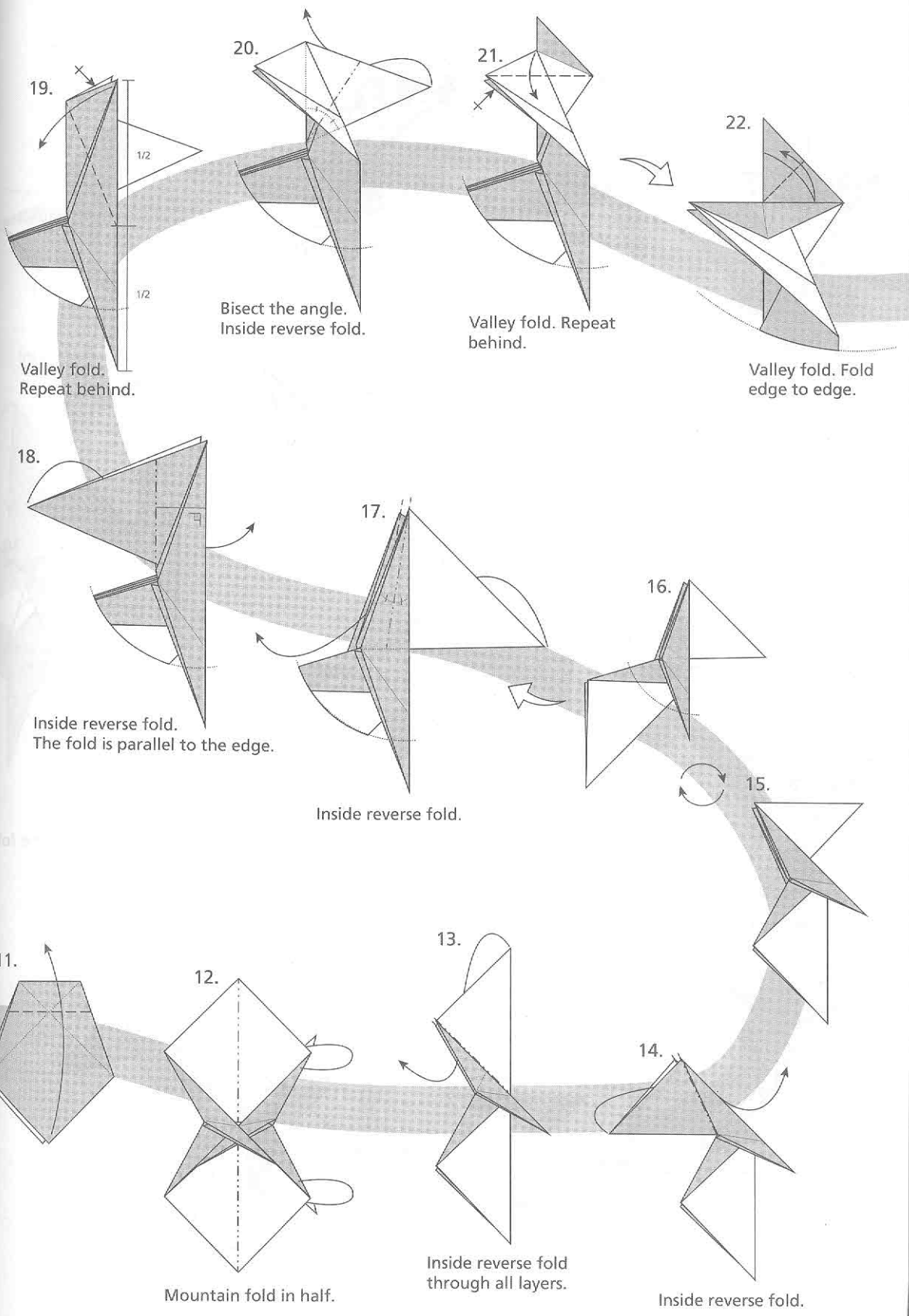

19. Valley fold. Repeat behind.

20. Bisect the angle. Inside reverse fold.

21. Valley fold. Repeat behind.

22. Valley fold. Fold edge to edge.

18. Inside reverse fold. The fold is parallel to the edge.

17. Inside reverse fold.

16.

15.

11.

12. Mountain fold in half.

13. Inside reverse fold through all layers.

14. Inside reverse fold.

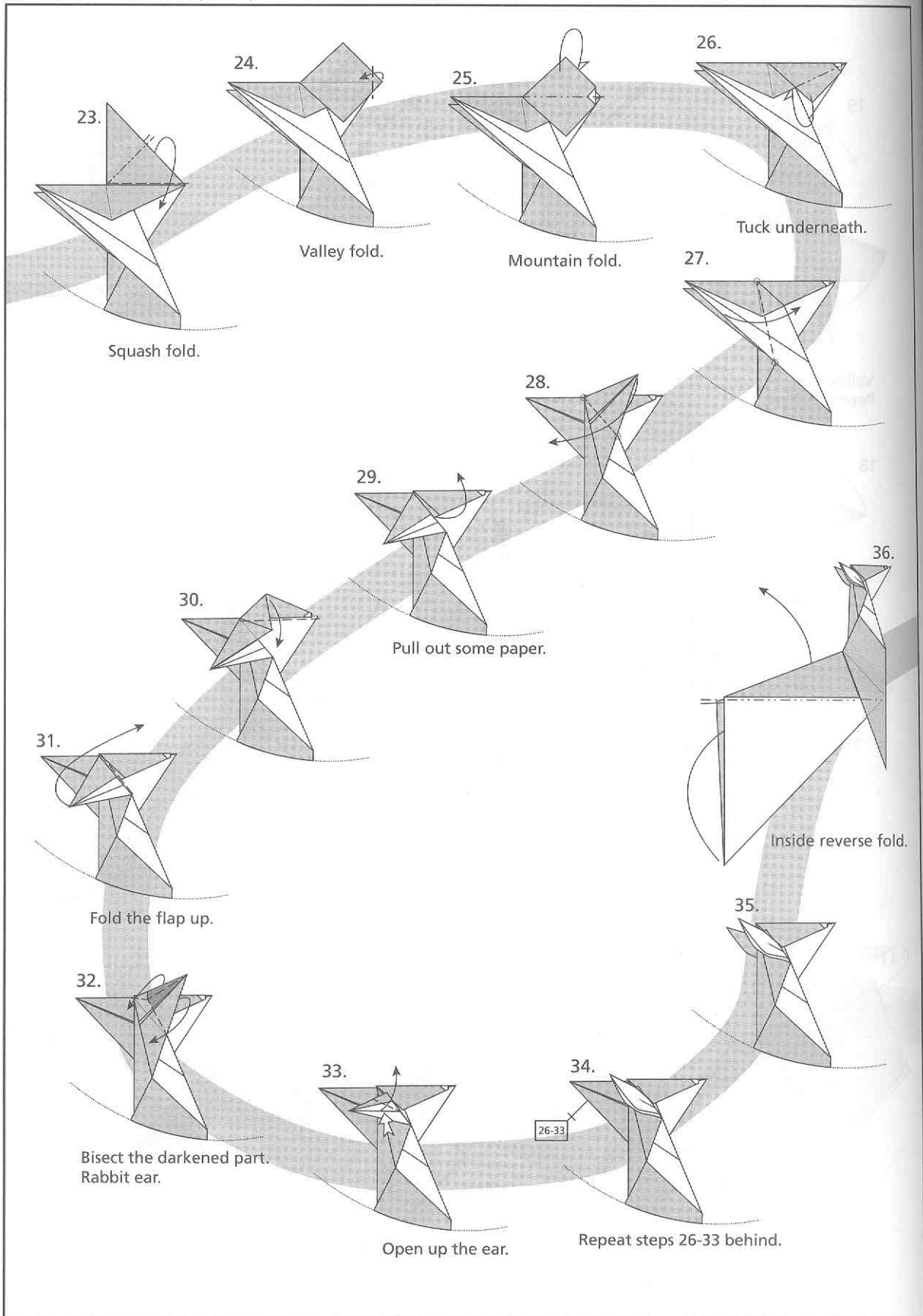

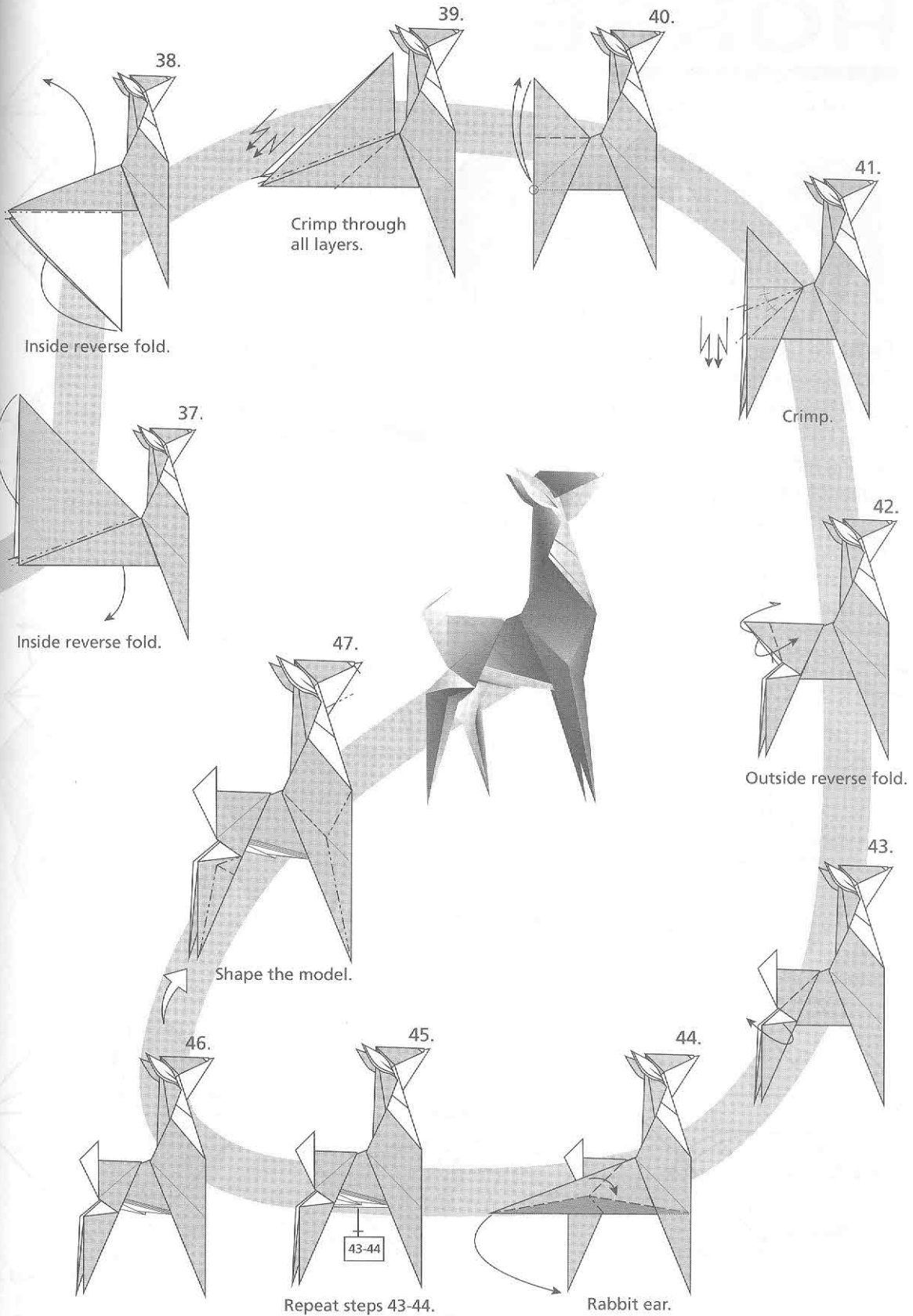

Inside reverse fold.

Crimp through all layers.

Crimp.

Inside reverse fold.

Outside reverse fold.

Shape the model.

Rabbit ear.

Repeat steps 43-44.

43-44

# HORSE

David S. Llanque Apaza.

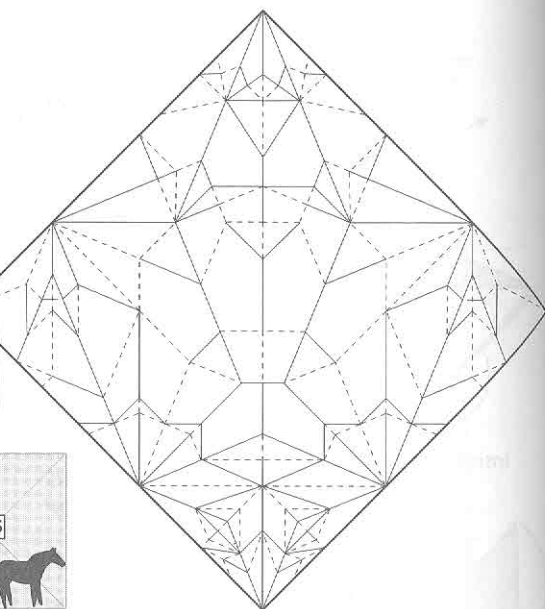
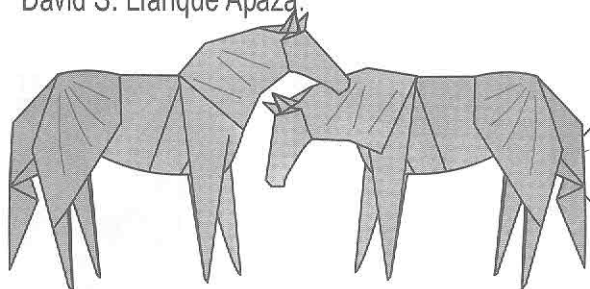

Fecha de Creacion: xx/07/2011

Fecha de diagramacion: xx/03/2013

Papel: Sandwish, unicolor etc.

NIVEL: 3

tamaño recomendado: 35cm

Comentarios: Ser muy precisos en las referencias usar de preferencia papel de 70 gramos a mas.

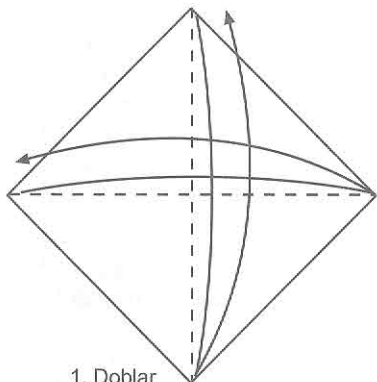
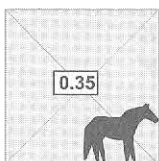

1. Doblar y desdoblar las diagonales.

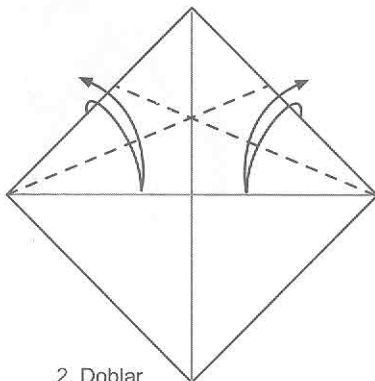

2. Doblar y desdoblar las bisectrices.

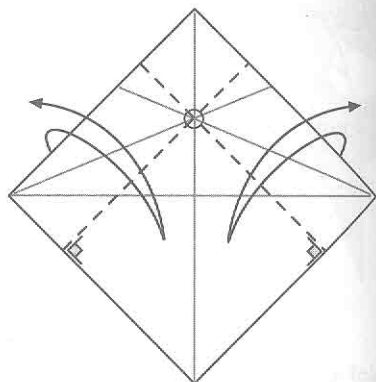

3. Doblar y desdoblar las perpendicularmente.

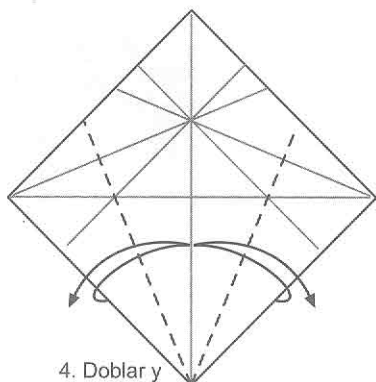

4. Doblar y desdoblar las bisectrices

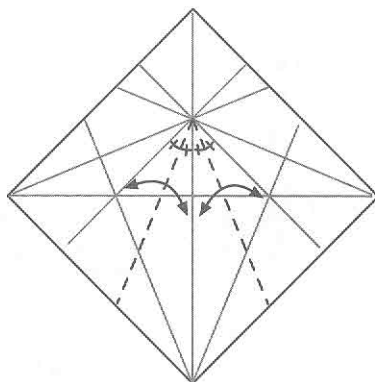

5. Marcar las bisectrices.

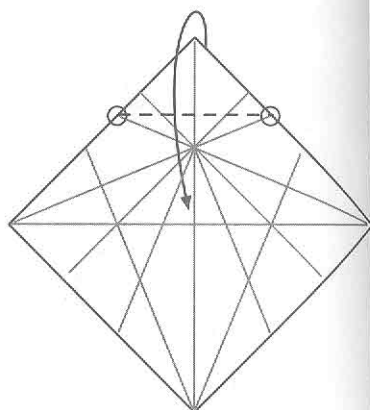

6. Bajar la punta por las marcas indicadas.

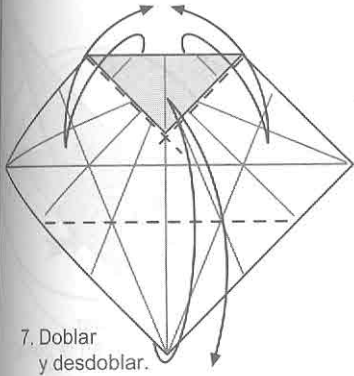

7. Doblar y desdoblar.

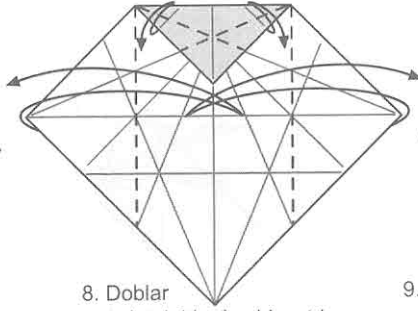

8. Doblar y desdoblar las bisectrices y las puntas laterales.

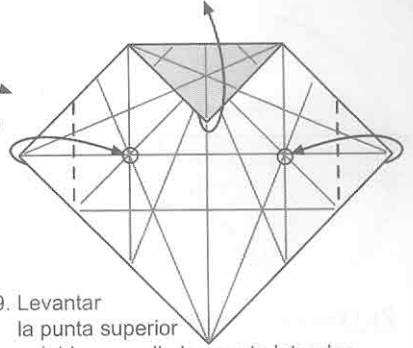

9. Levantar la punta superior y doblar en valle las punta laterales.

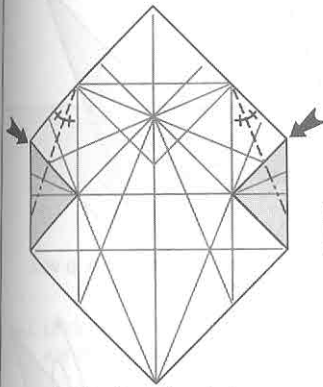

10. Undir ambos lados.

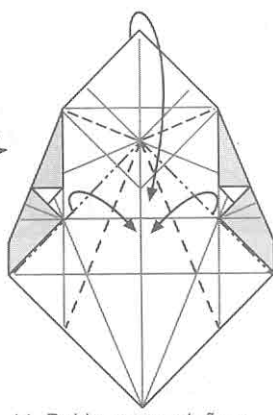

11. Doblar en montaña y bajar la punta superior.

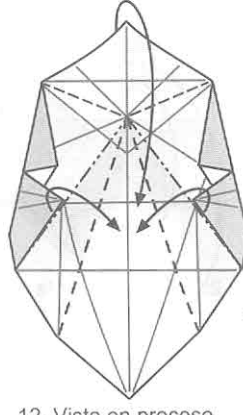

12. Vista en proceso.

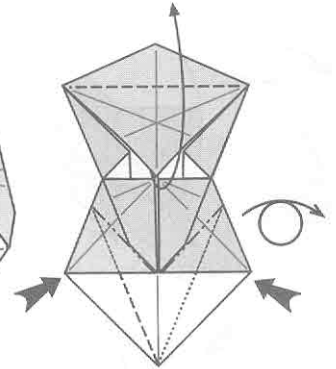

13. Levantar la punta hacia arriba y undir los costados.

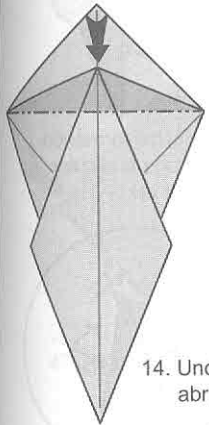

14. Undir abriendo.

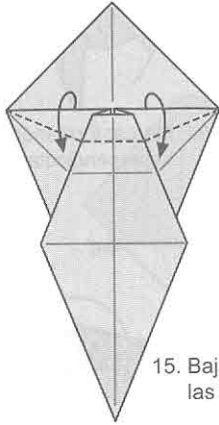

15. Bajar las capas.

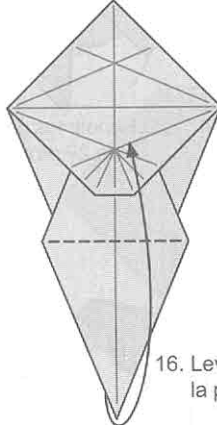

16. Levantar la punta.

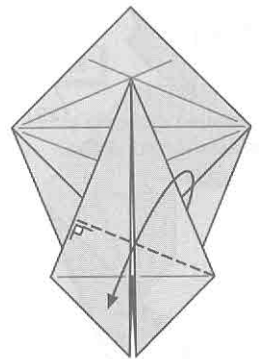

17. Doblar en valle en angulo recto.

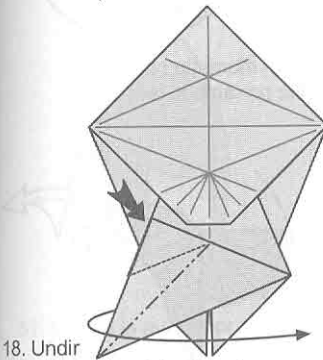

18. Undir y llevar hacia la derecha a la mismavez.

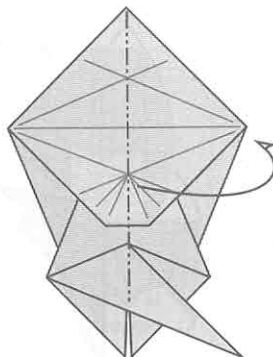

19. Doblar por la mitad.

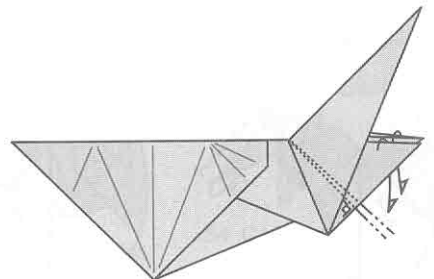

20. Bajar las dos puntas al mismo tiempo formando el angulo recto como se indica.



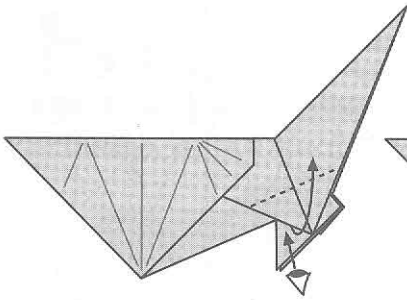

21. Levantar suavemente, vista interior.

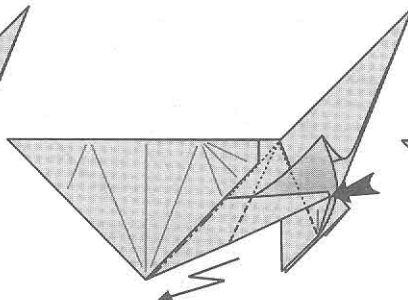

22. Undir y hacer un dobles escalonado a la vez.

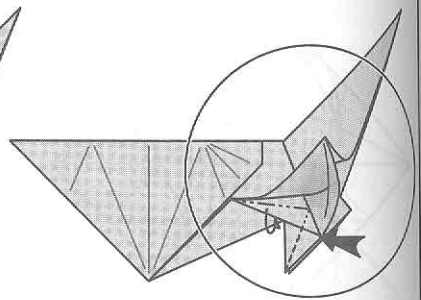

23. Undir y esconder. Concentrarse en la zona.

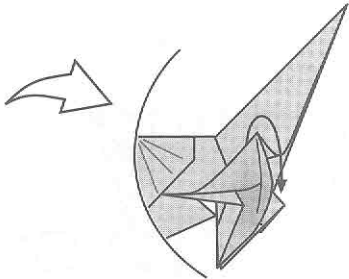

24. Bajar la punta.

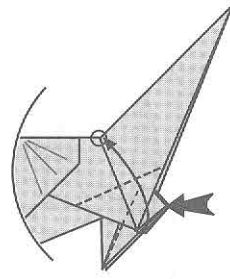

25. Undir y llevar la punta hacia la marca indicada.

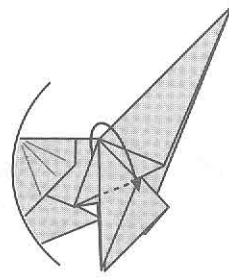

26. Dobra en valle.

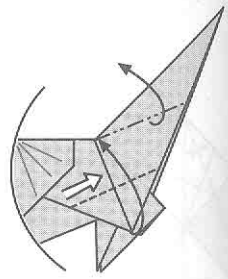

27. Undir y levantar a la vez.

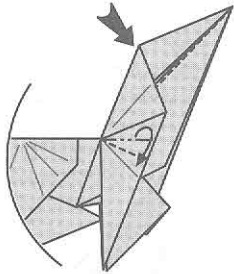

28. Doblar en montaña aplastando por arriba.

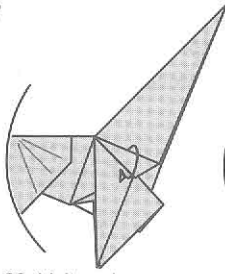

29. Voltear la capa.

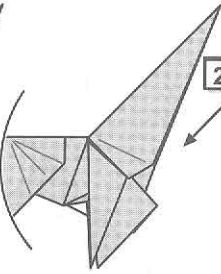

30. Repetir los pasos 21 a 29 atrás.

21-29

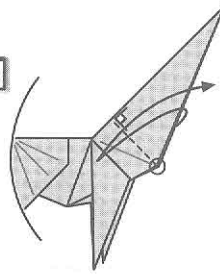

31. Marcar formando la perpendicular.

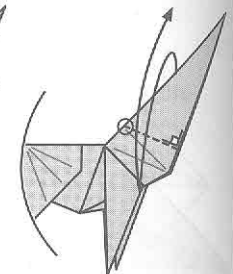

32. Marcar formando la perpendicular otra vez.

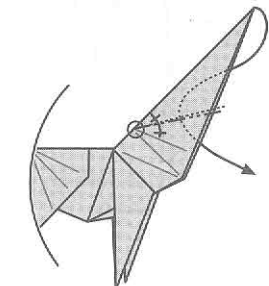

33. Invertir la punta por la bisectriz.

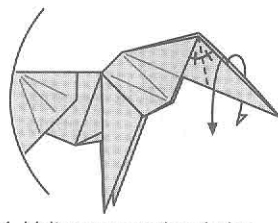

34. Voltear por ambos lados.

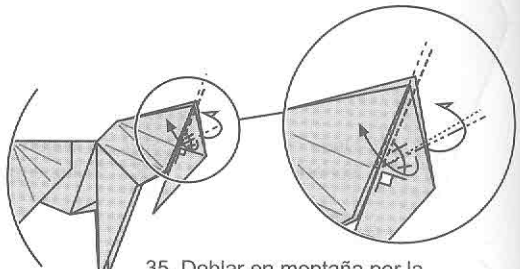

35. Doblar en montaña por la bisectriz por ambos lados.

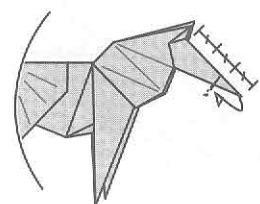

36. Esconder la punta.

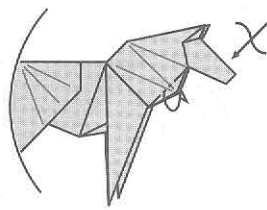

37. Voltear.

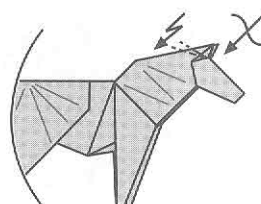

38. Escalonar las orejas.

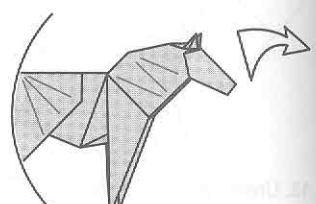

39. Pasar a vision completa.

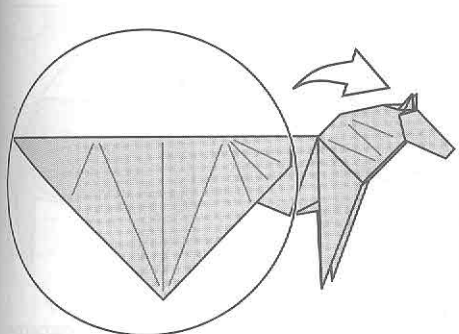

40. Concentrarse en la nueva zona.

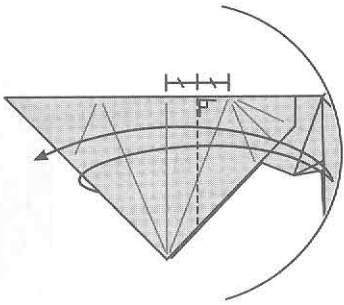

41. Doblar y desdoblar por la mitad.

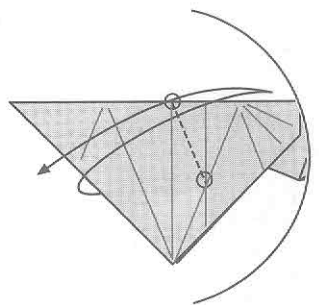

42. Marcar de punto a punto.

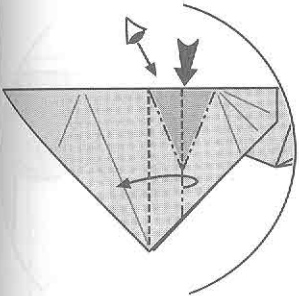

43. Undir la parte sombreada abriendo el modelo.

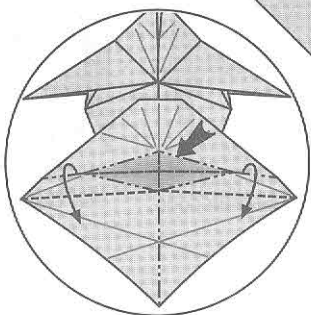

44. Vision por arriba. Doblar segun las marcas asignadas.

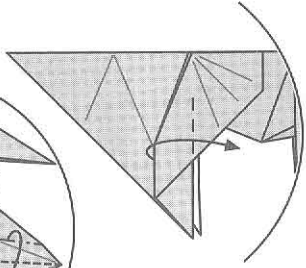

45. Llevar hacia la derecha.

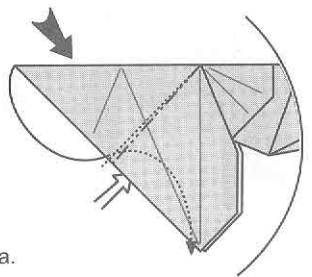

46. Invertir la punta.

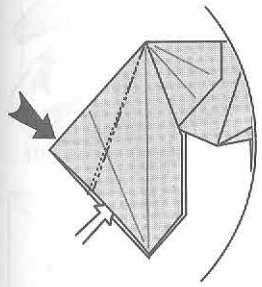

47. Aplastar un capa.

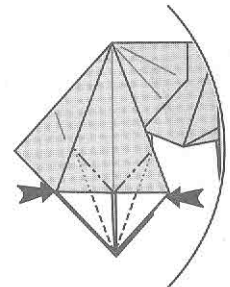

48. undir ambos lados.

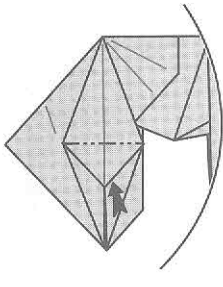

49. Undir la punta.

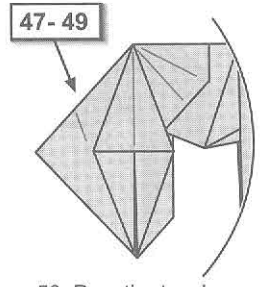

50. Repetir atraz los pasos 47 a 59.

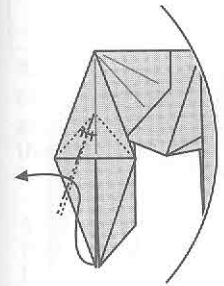

51. Invertir la punta por la bisectriz.

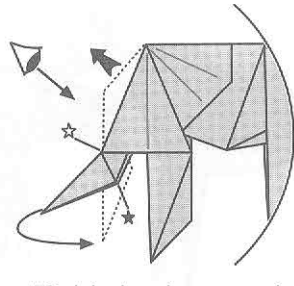

52. Jalar la cola y sacar el papel al mismo tiempo, vision de arriba.

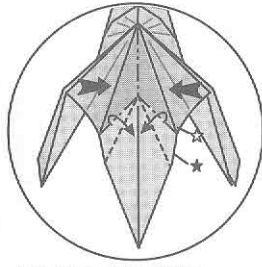

53. Vision de arriba. presionar los costados y doblar en monte.

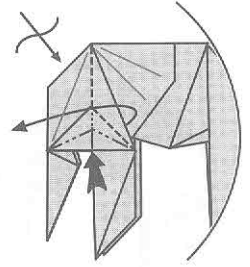

54. Cerrar en conjunto presionando por abajo.

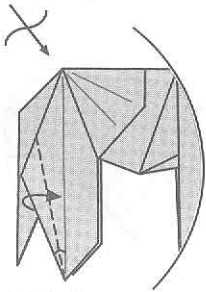

55. Doblar en valle.

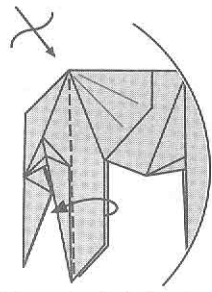

56. Llevar hacia la izquierda.

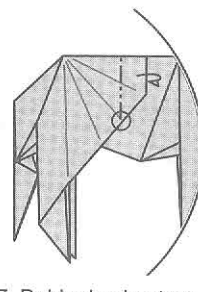

57. Doblar hacia atraz.

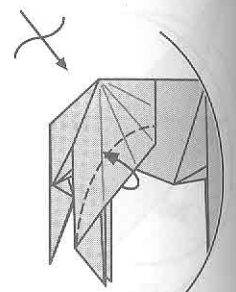

58. Levantar suavemente.

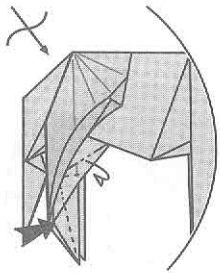

59. Esconder las capas hacia adentro.

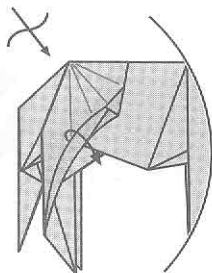

60. Bajar la capa .

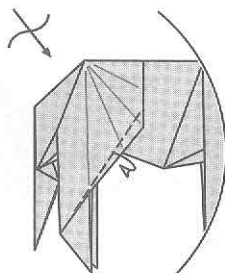

61. Esconder un poco.

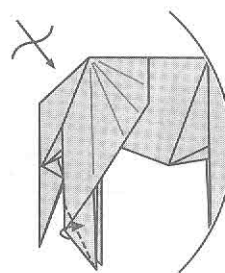

62. Doblar en valle.

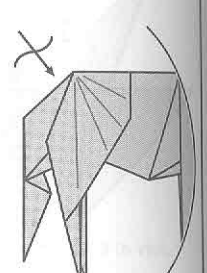

63. Repetir atraz.  
Vision completa.

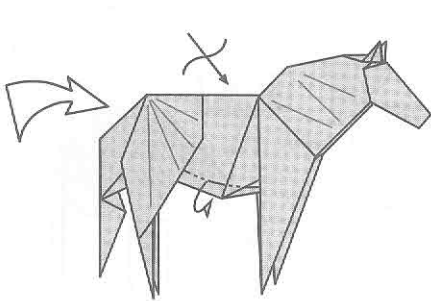

64. Esconder dando volumen al abdomen.

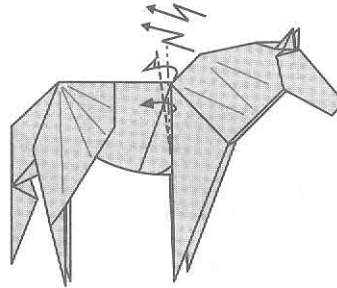

65. Levantar la parte delantera haciendo un doblez escalonado por ambos lados.

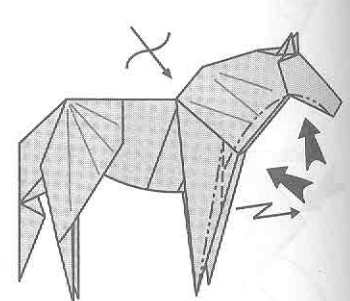

66. Dar formam al cuello y patas.

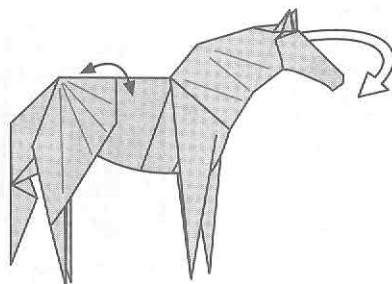

67. Girar el cuello y curvar el lomo.

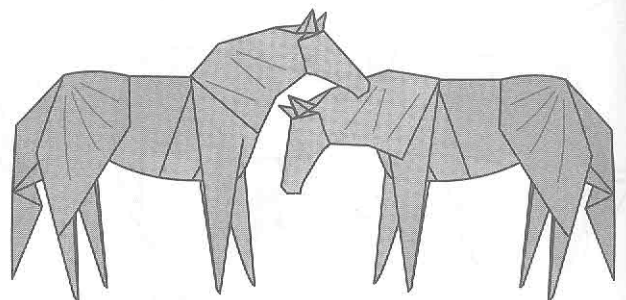

Modelo terminado.

# Grizzly Bear

by Seth Friedman  
Designed: 2010-2012

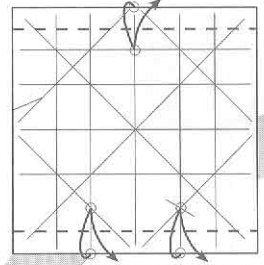
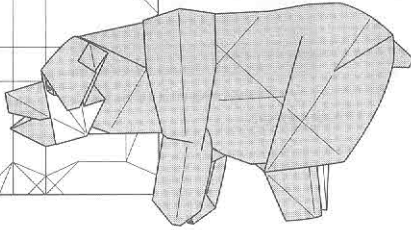
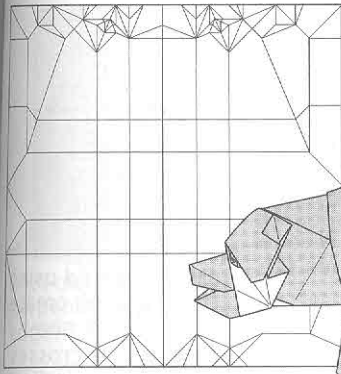

12. Fold the top and bottom edges to the indicated points.

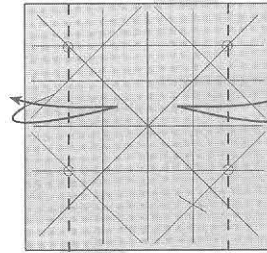

11. Make two creases that cross through the indicated points. Turn over.

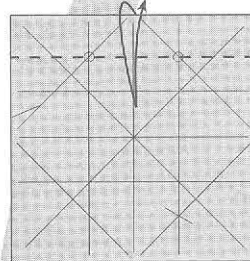

10. Make a crease that crosses through the indicated points.

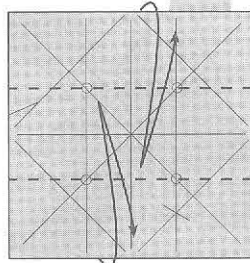

9. Make two creases that cross through the indicated points.

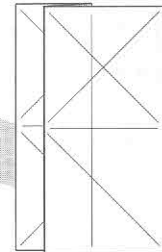

8. Unfold completely. Turn over.

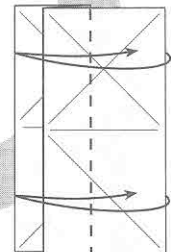

7. Fold the right edge to meet the left edge. Unfold.

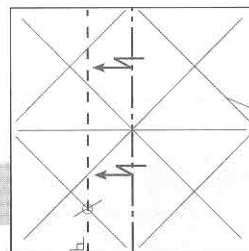

6. Using the pinch from the last step, pleat along the indicated lines.

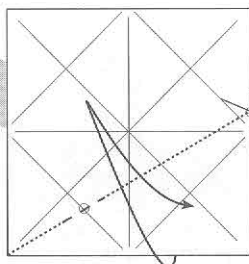

5. Make a light crease that connects the pinch from the last step and the bottom left corner. Make a sharp crease where it intersects the indicated line.

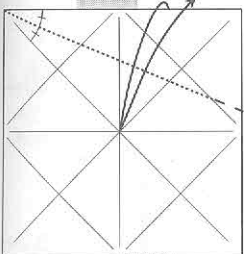

4. Bring the top edge to the diagonal fold and make a pinch on the right edge.

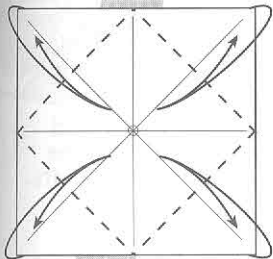

3. Fold the corners to the center and unfold.

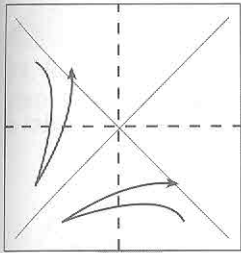

2. Fold and unfold.

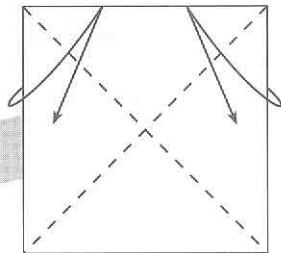

1. Fold and unfold.

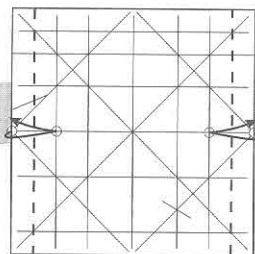

13. Fold the left and right edges to the indicated points. Turn over.

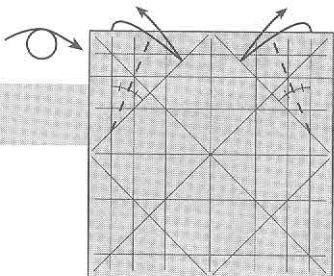

14. Fold two angle bisectors.

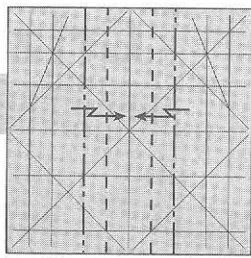

15. Pleat towards the center.

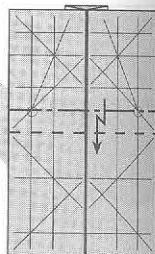

16. Pleat fold using one existing crease, and make a new crease that crosses through the indicated points.

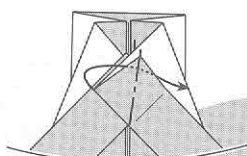

19. Inside reverse fold along an existing crease.

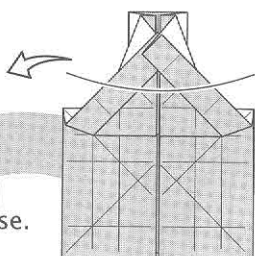

18. Result. The next step focusses on the top.

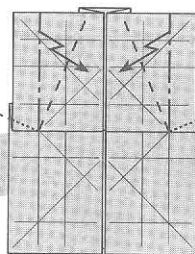

17. Pleat fold using existing creases.

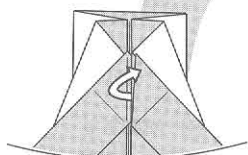

20. Bring the flap on the left to the front.

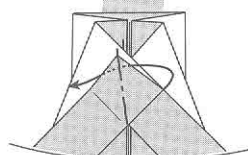

21. Repeat step 19 on the left.

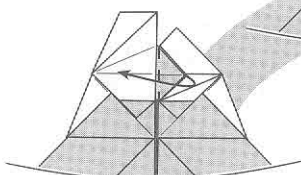

29. Fold the short flap over to the left.

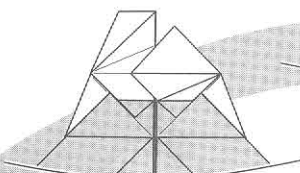

30. Repeat steps 27 and 28 on the right.

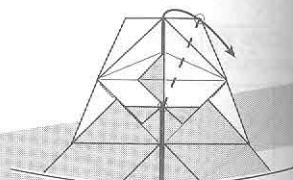

31. Valley fold connecting the indicated points.

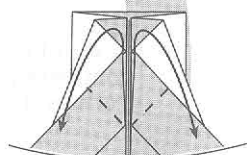

22. Fold the flaps down using existing creases.

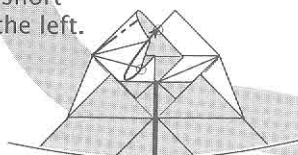

28. Flatten the model with a new mountain fold, bringing the indicated points together.

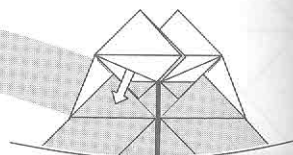

27. Pull out all the hidden layers.

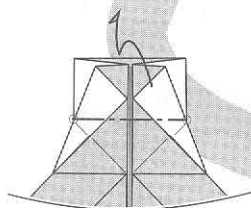

23. Fold and unfold connecting the indicated points.

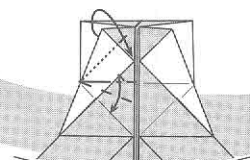

24. Swivel fold, bringing the raw edge at the top to the axis of symmetry.

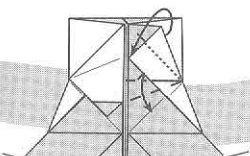

25. Repeat step 24 on the right.

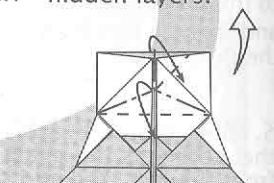

26. Rabbit ear through all layers.

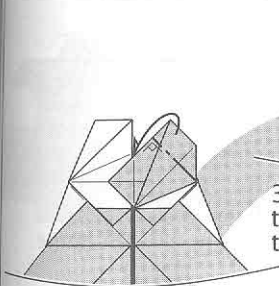

34. Fold the flap back perpendicular to the edge.

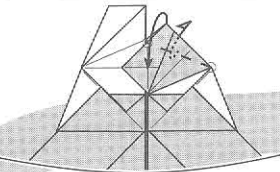

35. Valley fold just the top layer connecting the indicated points.

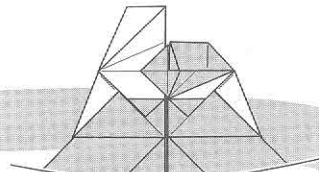

36. Unfold to step 34.

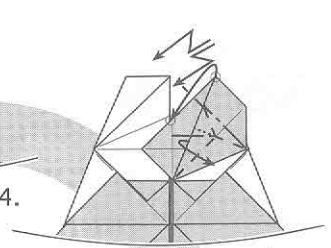

37. Crimp using the creases made in steps 34 and 35. Swivel the top layer, bringing edge to edge.

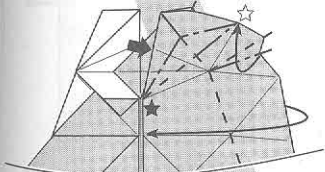

33. Refold to the state of step 32, while integrating a rabbit ear. Align the stars.

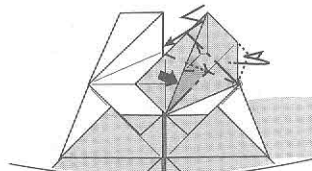

39. Using the same creases as in 37, sink the grey section. Simultaneously swivel some paper from behind at the point indicated by a circle.

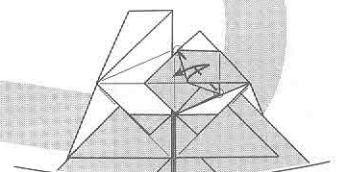

38. Fold and unfold connecting the indicated points. Unfold to step 37.

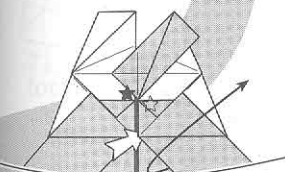

32. Lift the front layer up and out to the right.

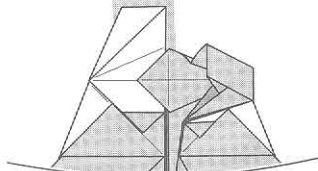

40. Step 39 in progress.

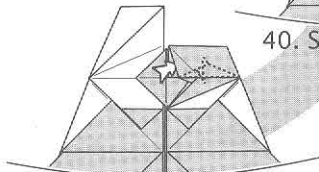

41. Completed result of step 39. Fold a hidden flap down.

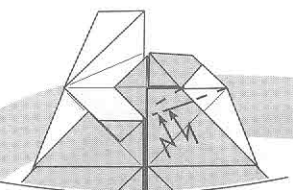

48. Crimp in and out. The left side of the crimp is a closed sink.

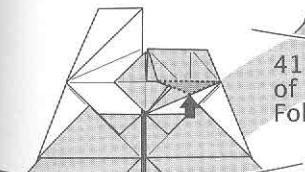

42. Closed-sink the hidden flap back up.

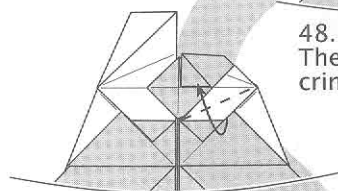

47. Valley fold along the natural hinge.

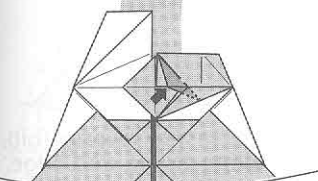

43. Closed sink the partially hidden flap using the crease made in step 38.

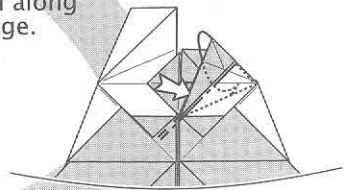

46. Open up the model partially and inside reverse fold.

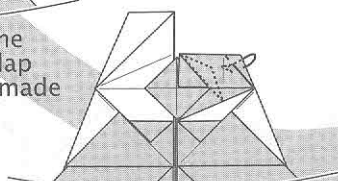

44. Inside reverse fold using an existing crease.

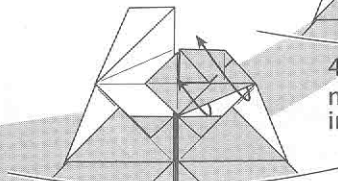

45. Valley fold at the natural hinge.

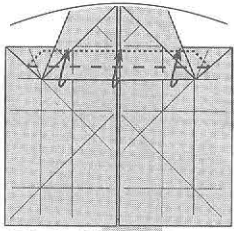

59. Fold the long edge straight up, nearly aligning it with the edge above.

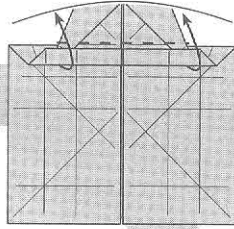

60. Fold the long edge straight up at the natural hinge.

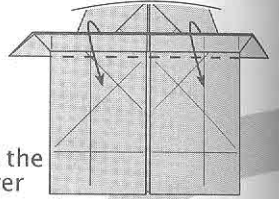

64. Fold the front layer down along the natural hinge.

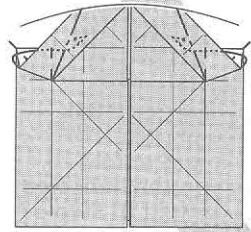

58. Inside reverse fold the front layer to wrap around the rear most edge.

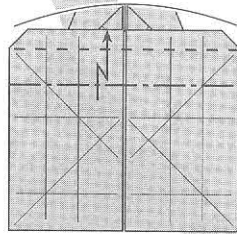

61. Pleat using existing creases.

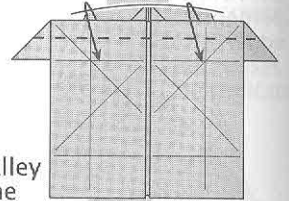

63. Valley fold the long edge down, so that it matches the edge behind it.

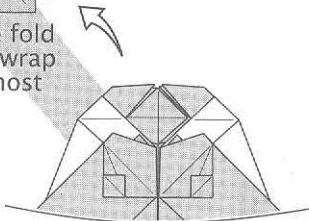

57. The following step focuses on the body.

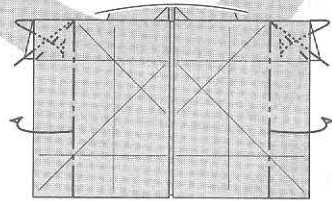

62. Inside reverse fold, and fold the outside edges behind.

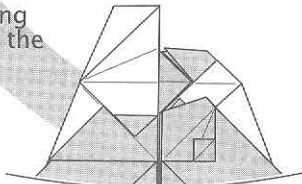

56. Repeat steps 31-54 on the left.

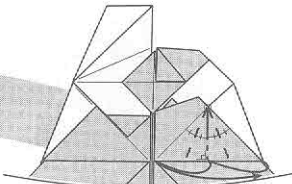

49. Fold and unfold along angle bisectors.

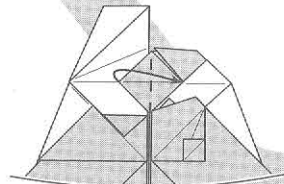

55. Valley fold along the natural hinge.

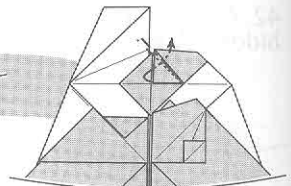

54. Inside reverse fold along the folded edge.

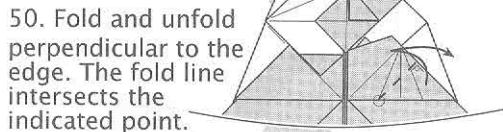

50. Fold and unfold perpendicular to the edge. The fold line intersects the indicated point.

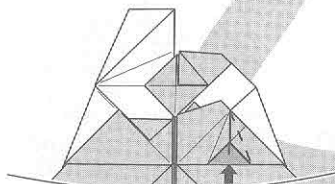

51. Fold along some of the creases made in the previous two steps. Push in the paper, and pleat.

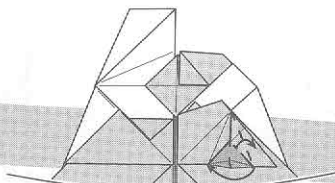

52. Pleat the same way on both front and back.

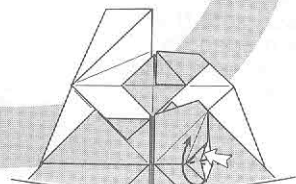

53. Squash fold.

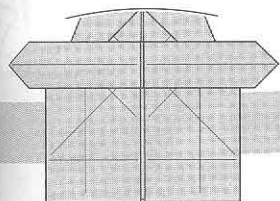

65. Turn over.

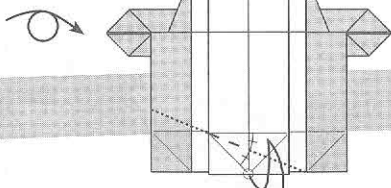

66. Fold and unfold bringing the indicated point to an existing crease. Fold through all layers.

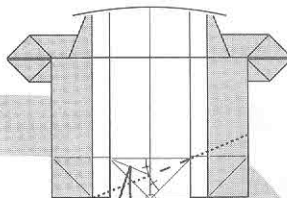

67. Repeat 66 on the right.

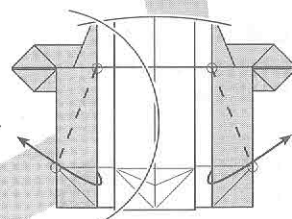

68. Valley fold the front layers out on both sides connecting the indicated points. The model will not lay flat.

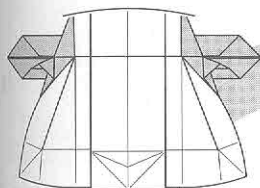

71. The next step focuses on the head.

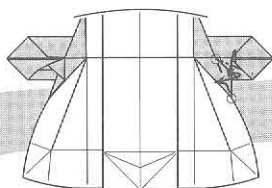

70. Repeat step 69 on the right.

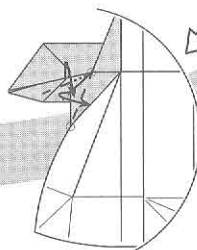

69. Swivel fold by making a valley fold connecting the indicated points. The corner of the layer behind gets valley folded down in the process.

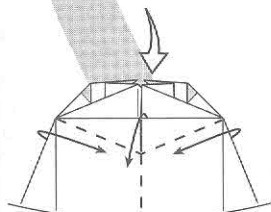

72. Begin to fold the model in half incorporating an inside reverse fold.

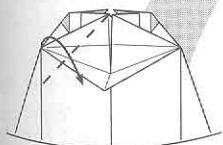

73. Fold the left corner in along a natural hinge.

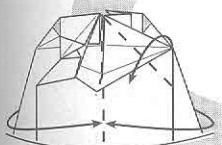

74. Repeat step 73 on the right. Simultaneously fold the head in half. Below the head, round the back into a `U` shape. The next step is a side view of the entire model.

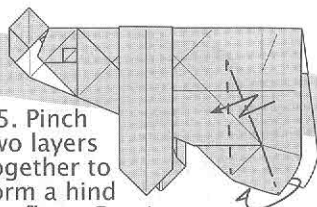

75. Pinch two layers together to form a hind leg flap. Continue to pinch up towards the body, then pleat the leg forward, toward the head. Repeat behind.

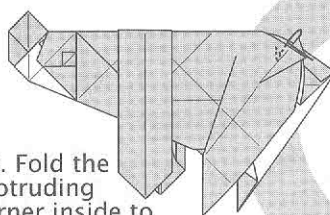

78. Fold the protruding corner inside to form a lock.

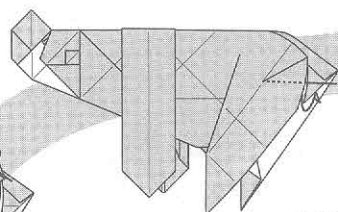

79. Mountain fold half of the tail flap up and inside.

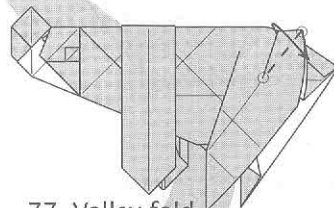

77. Valley fold connecting the indicated points.

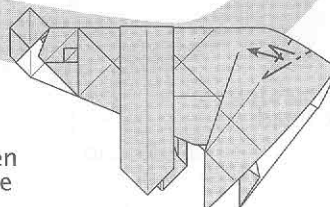

76. Using the creases made in step 66 and 67 pleat just the top layer.



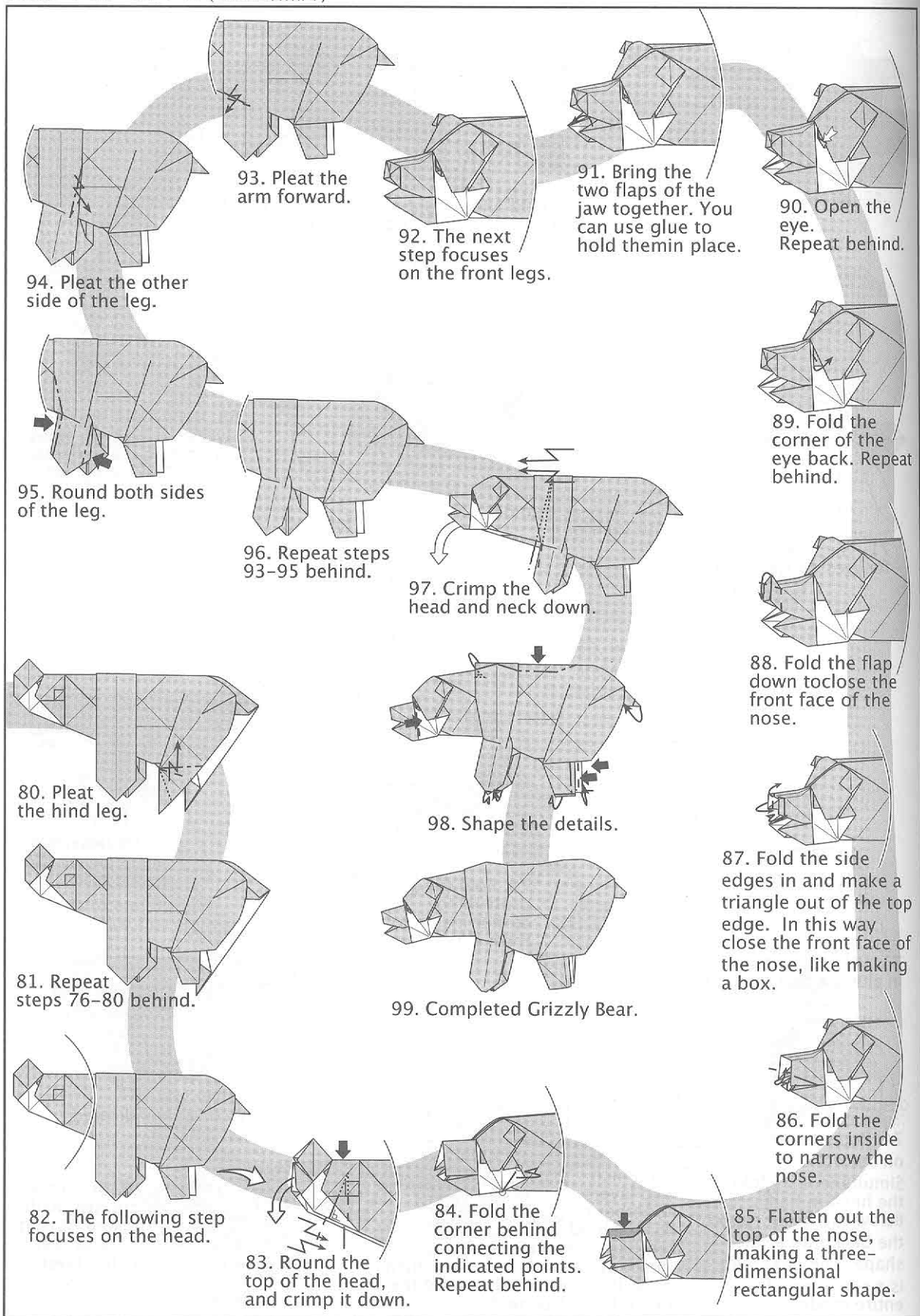

93. Pleat the arm forward.

92. The next step focuses on the front legs.

91. Bring the two flaps of the jaw together. You can use glue to hold them in place.

90. Open the eye. Repeat behind.

94. Pleat the other side of the leg.

89. Fold the corner of the eye back. Repeat behind.

95. Round both sides of the leg.

96. Repeat steps 93-95 behind.

97. Crimp the head and neck down.

88. Fold the flap down to close the front face of the nose.

80. Pleat the hind leg.

98. Shape the details.

87. Fold the side edges in and make a triangle out of the top edge. In this way close the front face of the nose, like making a box.

81. Repeat steps 76-80 behind.

99. Completed Grizzly Bear.

82. The following step focuses on the head.

83. Round the top of the head, and crimp it down.

84. Fold the corner behind connecting the indicated points. Repeat behind.

85. Flatten out the top of the nose, making a three-dimensional rectangular shape.

# Stock Bull

Designer Andrey Ermakov

Difficulty: \*\*\*\*\*

Paper: 40 50 g/m

For size: 50 50 cm<sup>2</sup>

Length: 20 cm

Time: 5 hours

Russia / Saint-Petersburg

05.06.2013

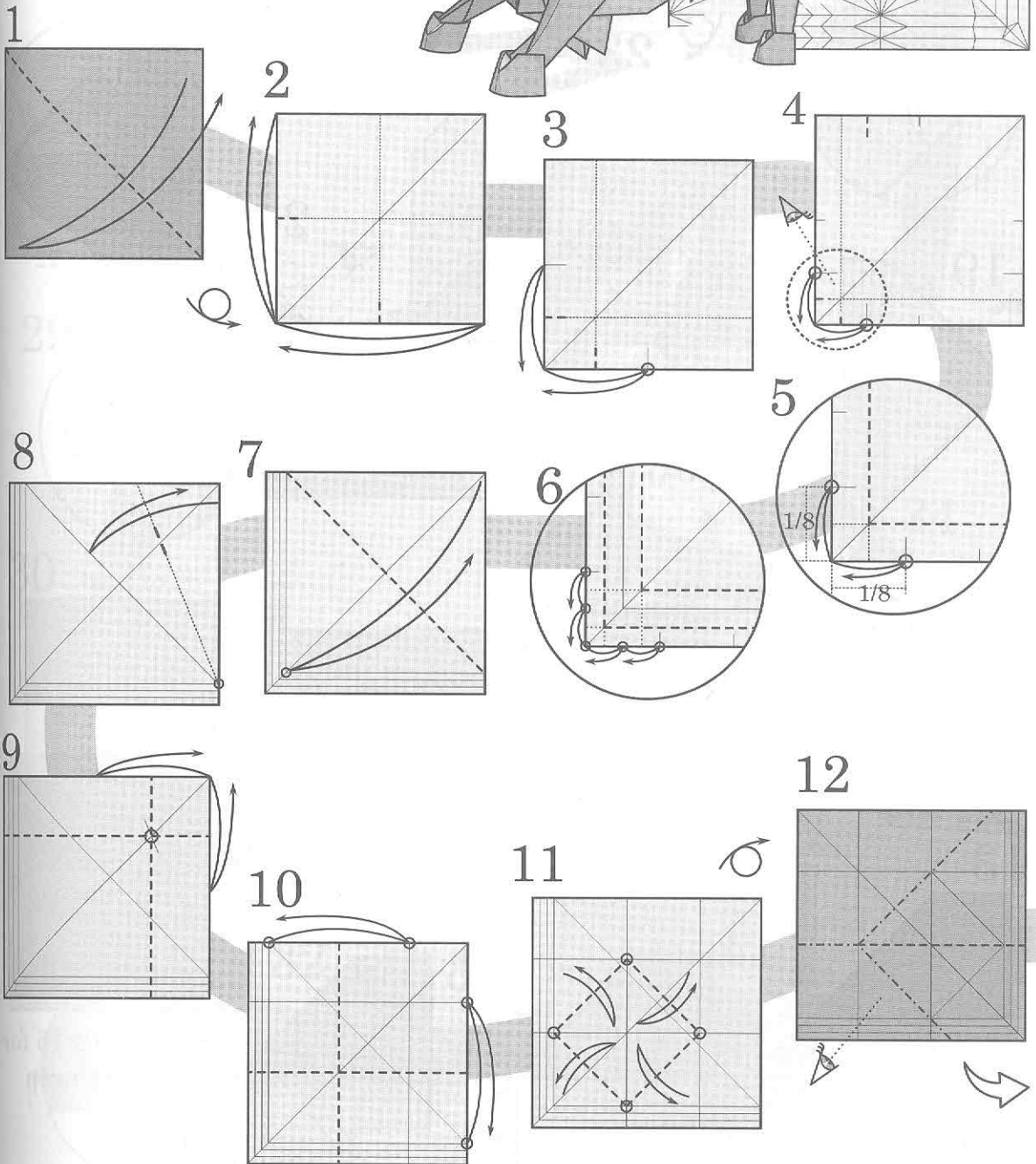
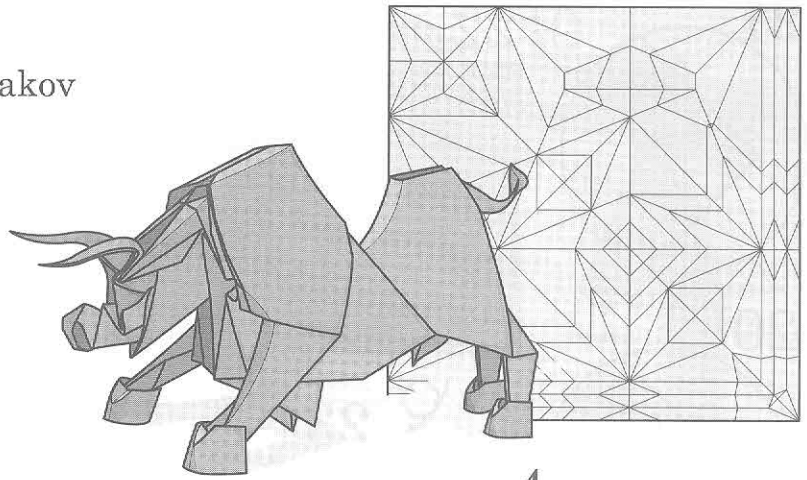

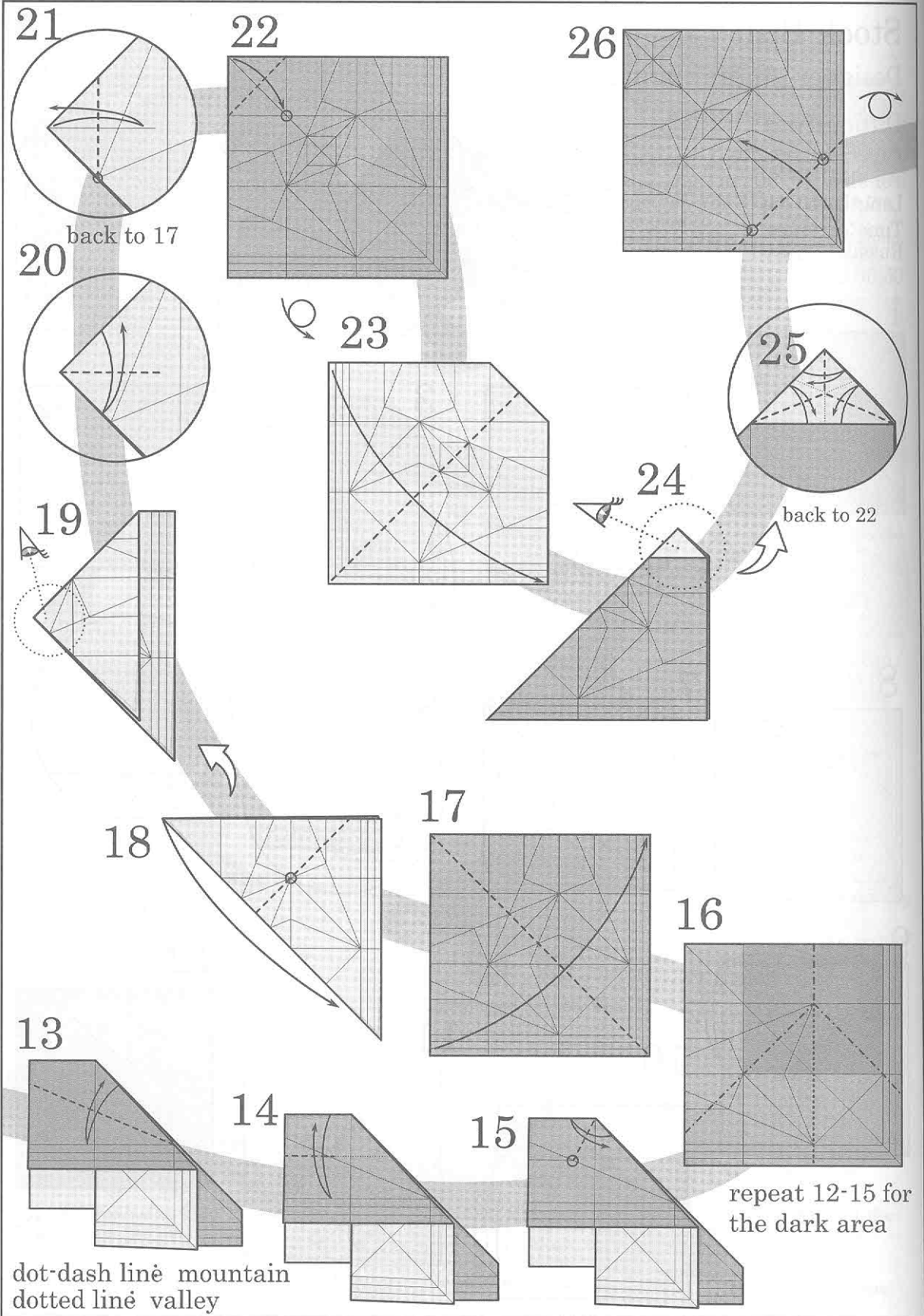

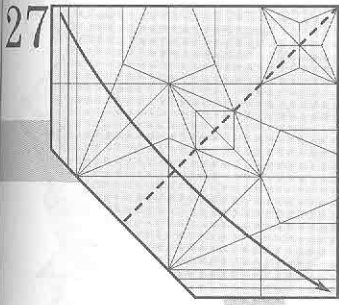

28

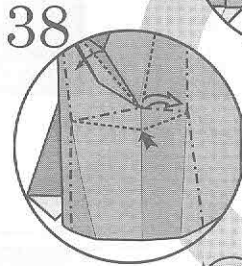
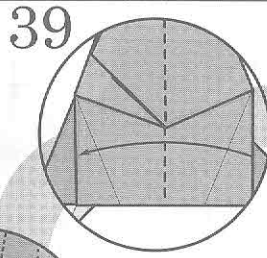
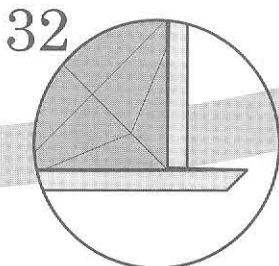
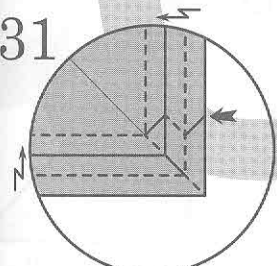
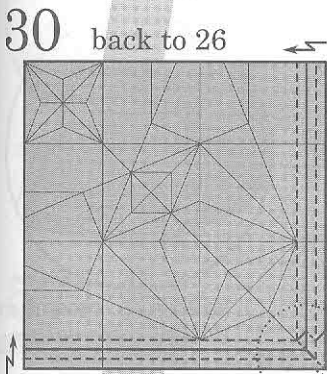
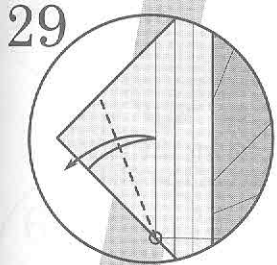
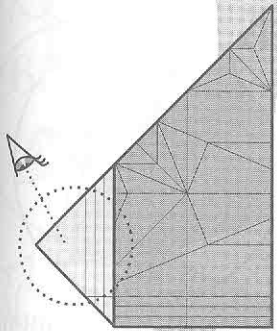

90°

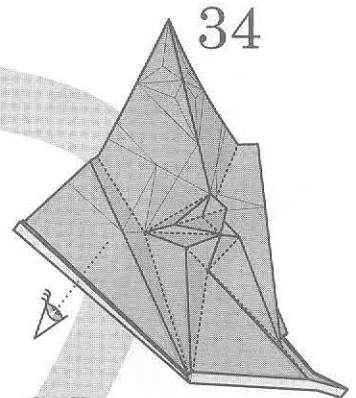
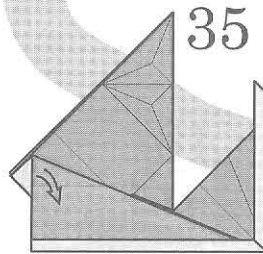
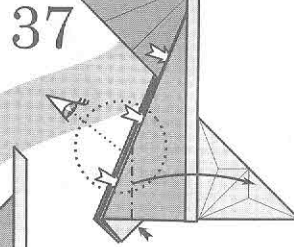
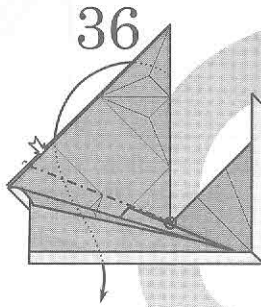

33  
fold the form using the lines

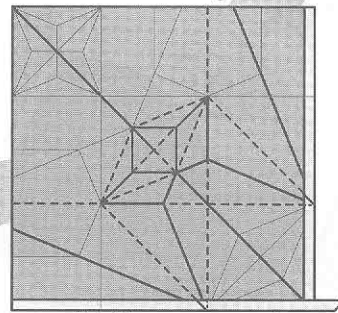

solid line: mountain  
dotted line: valley

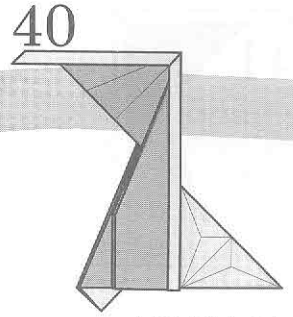

repeat 37-39 behind

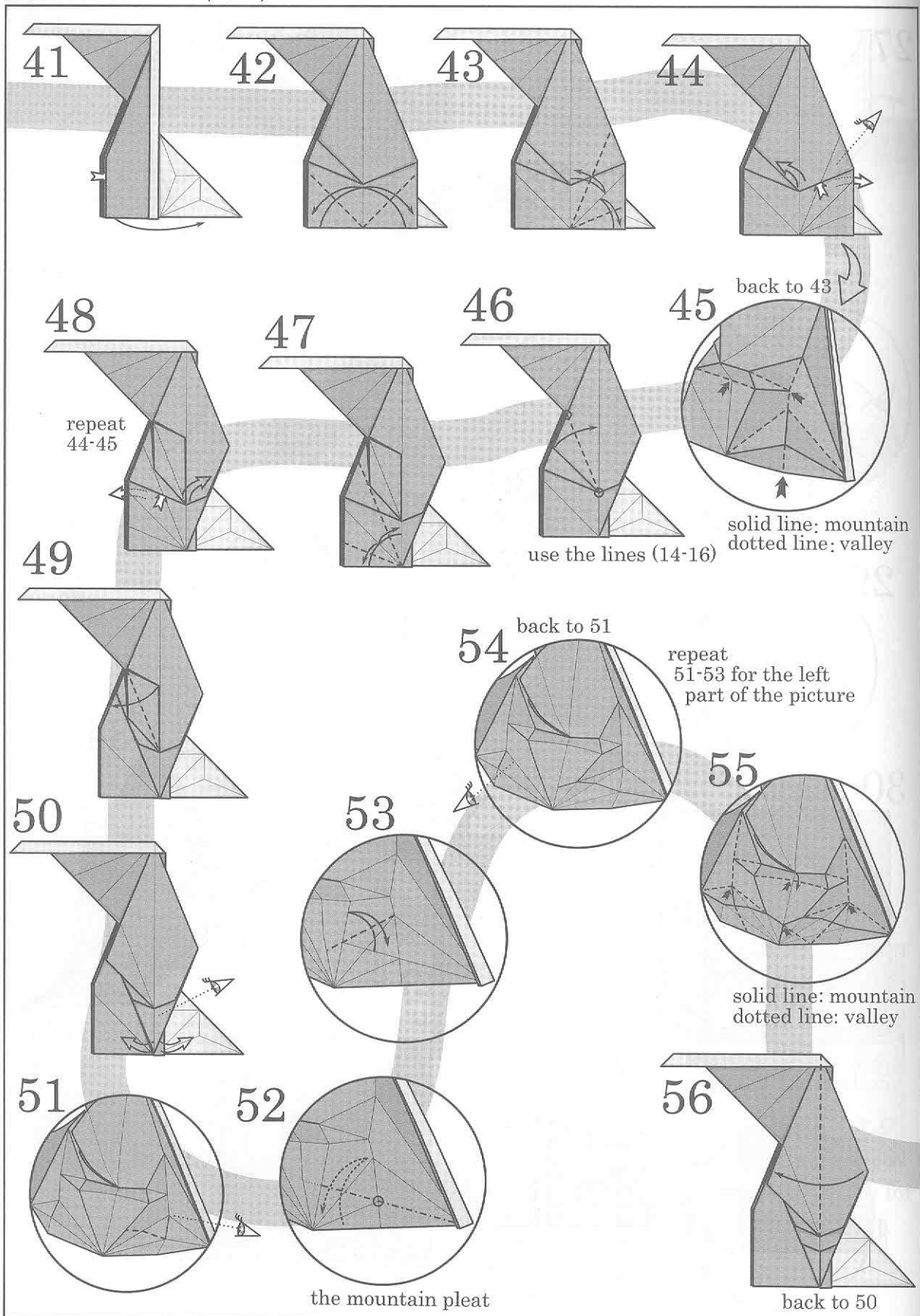

66

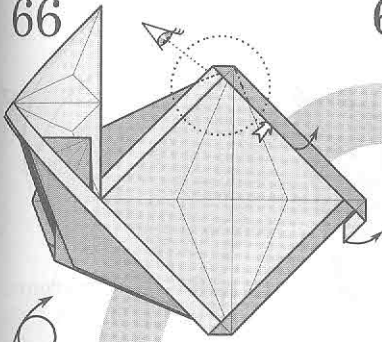

67

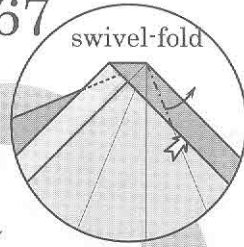

72

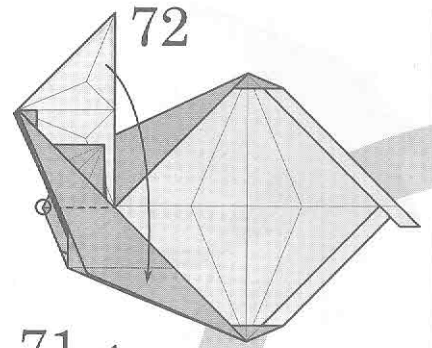

65

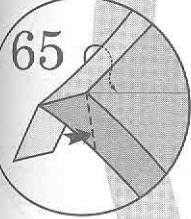

68

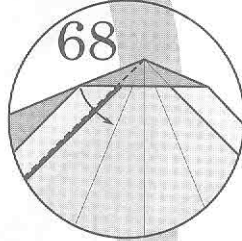

71

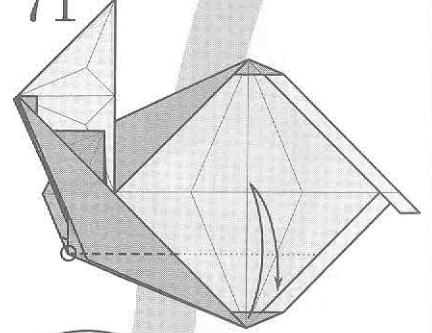

64

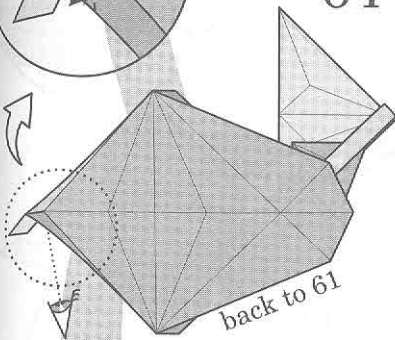

69

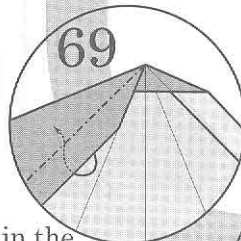

70

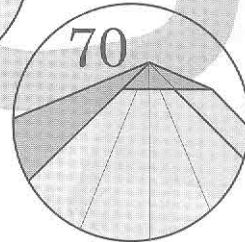

put in the nearest pocket

repeat 66-69 below

63

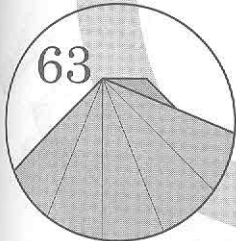

repeat step 62 below

62

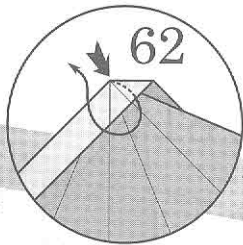

61

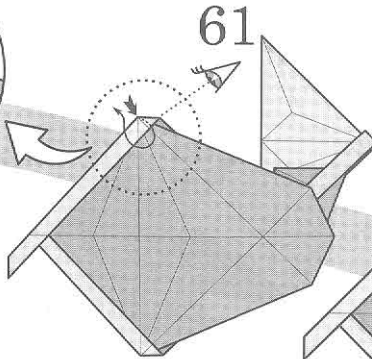

60

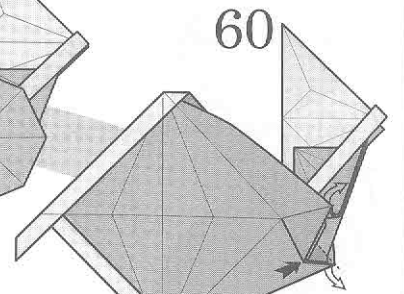

57

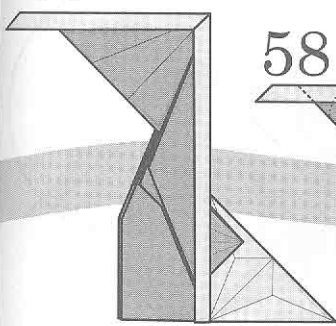

repeat 41-56 behind

58

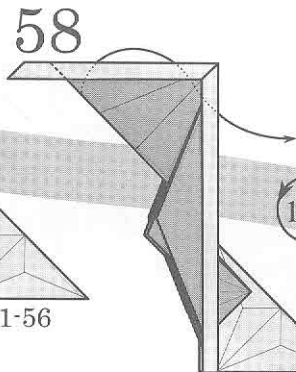

135°

59

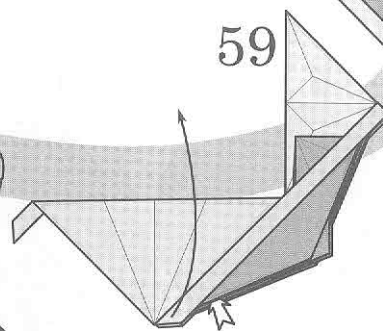

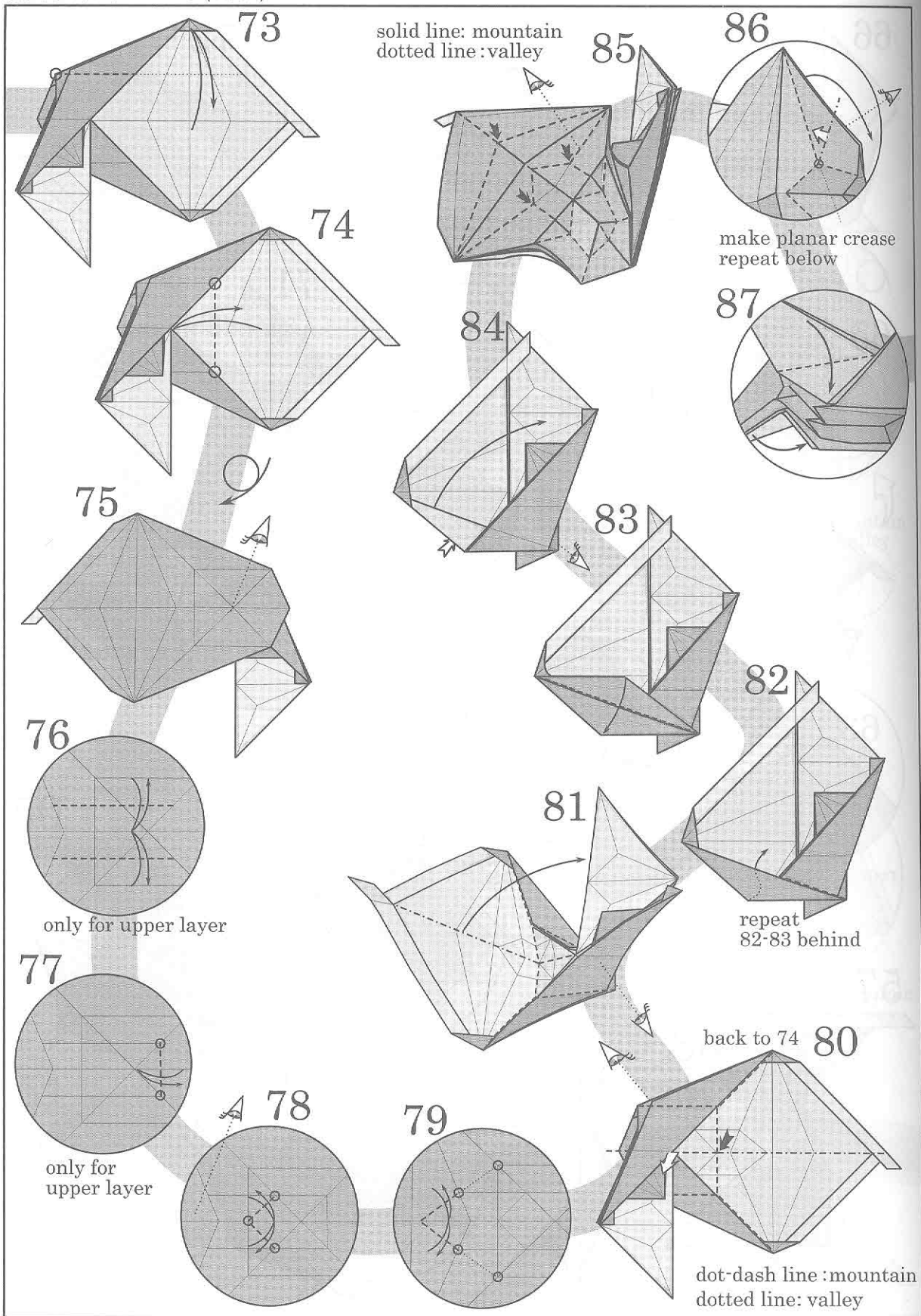

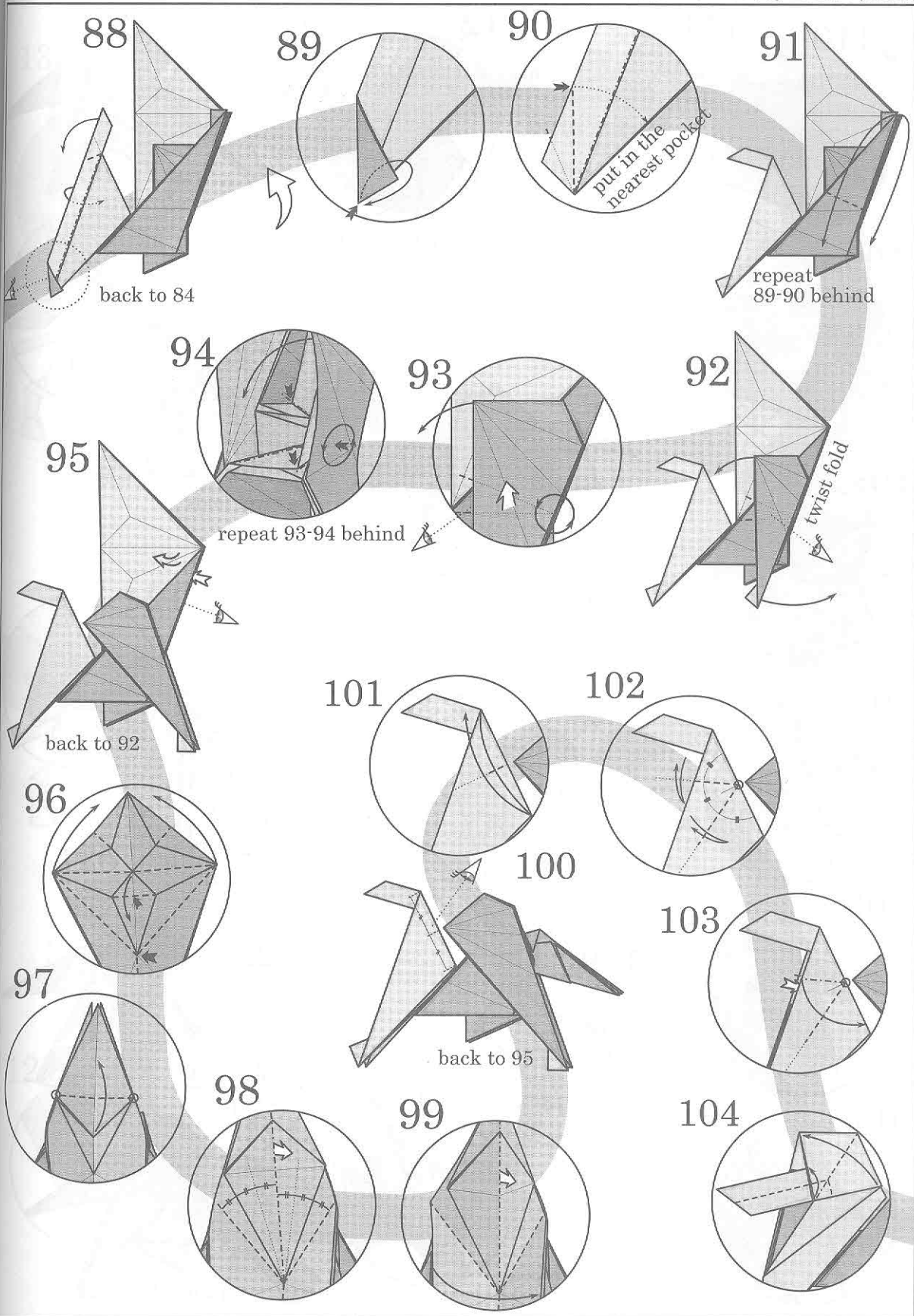



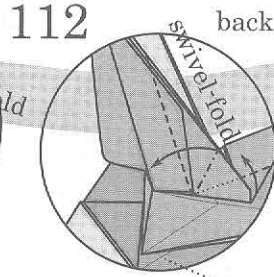
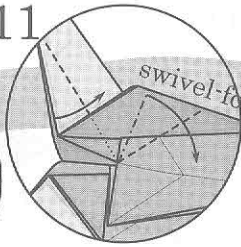
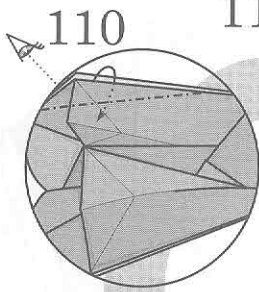

back to 100

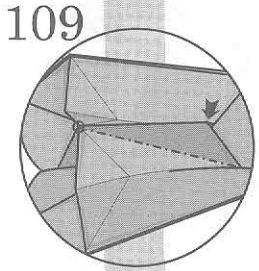
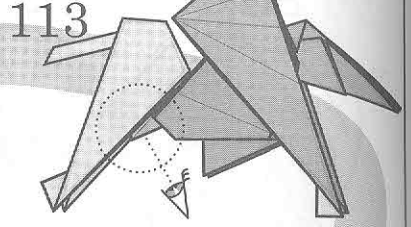

repeat 109-112 below

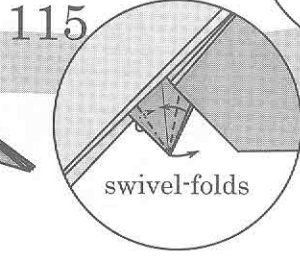
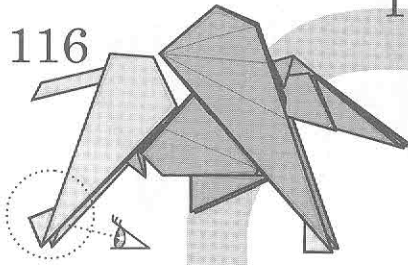
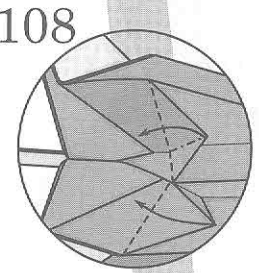
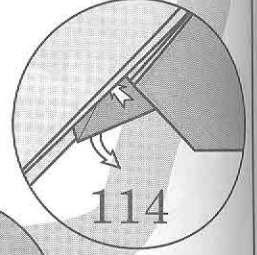

repeat behind

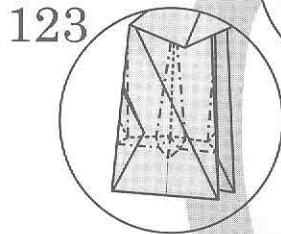
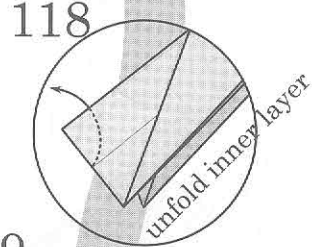
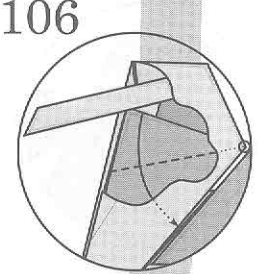
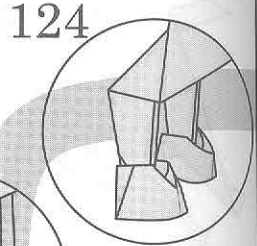
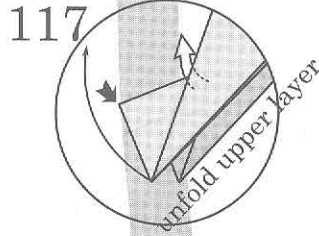
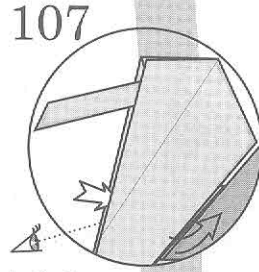

repeat behind

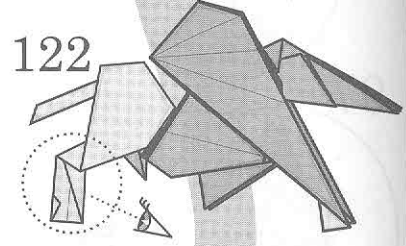
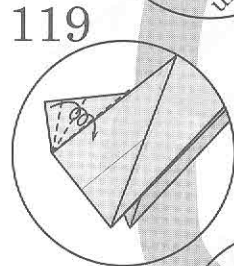
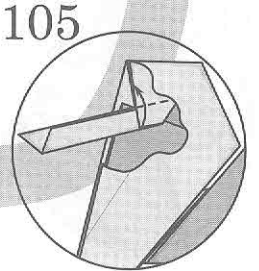

repeat 117-119 behind

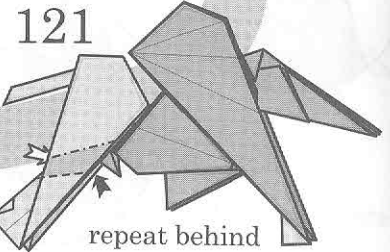
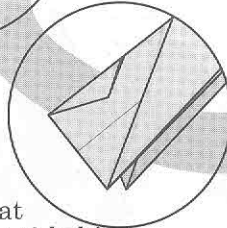

repeat behind

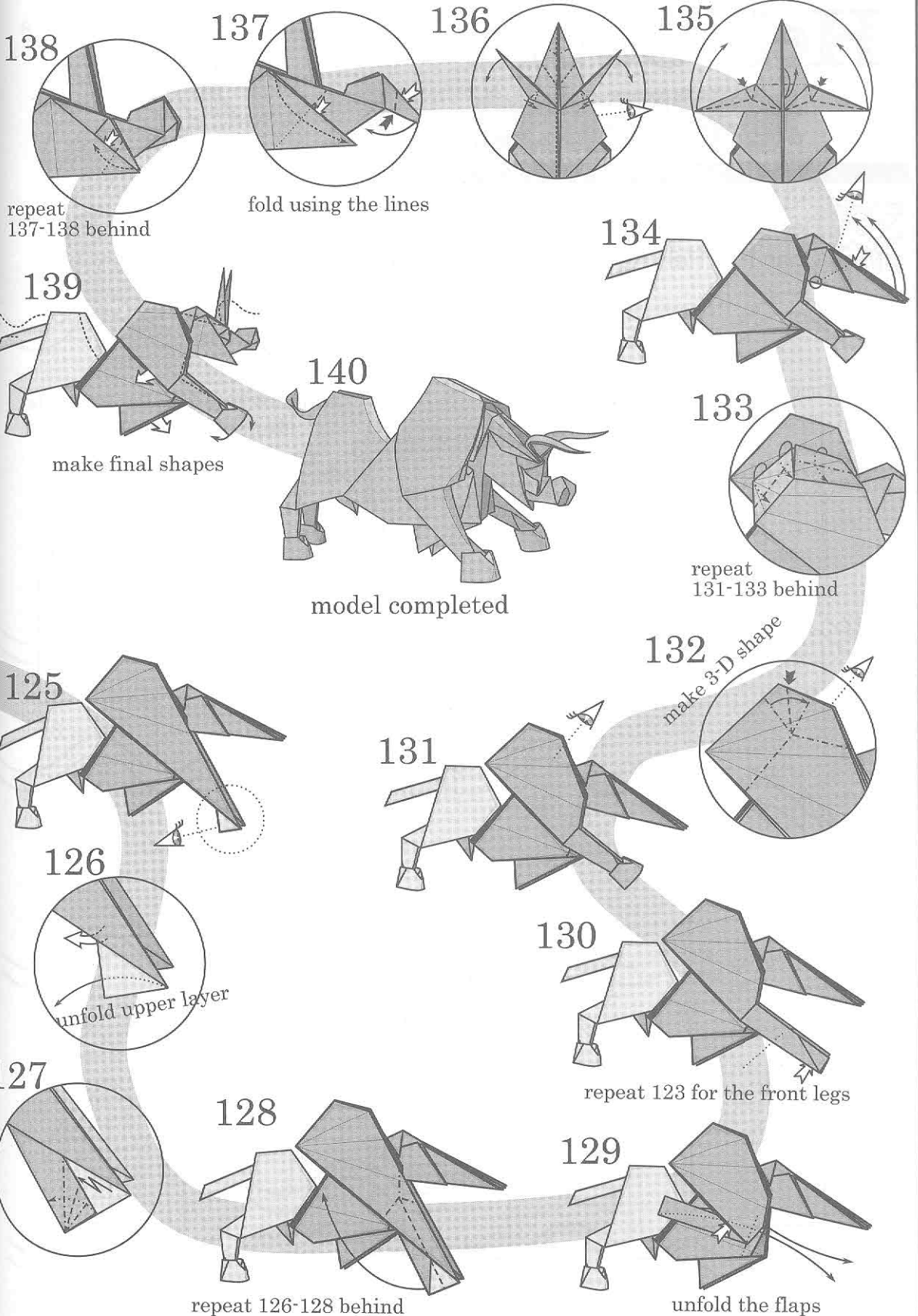

138  
repeat  
137-138 behind

137  
fold using the lines

136

135

139  
make final shapes

134

140  
model completed

133  
repeat  
131-133 behind

125

132  
make 3-D shape

131

126  
unfold upper layer

130  
repeat 123 for the front legs

127

128  
repeat 126-128 behind

129  
unfold the flaps

# Hell Cobra 地獄眼鏡蛇



Designed and diagramed by :  
Chan Pak Hei , Kade 陳柏熹 (Hong Kong)

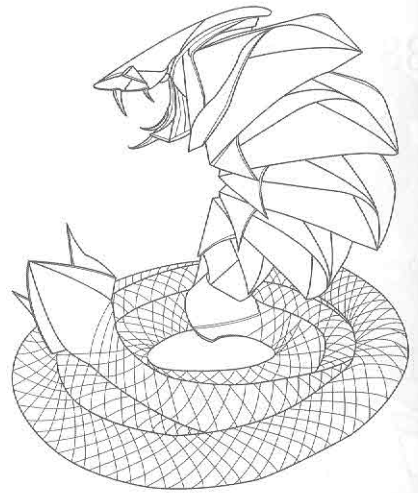

1. Paper scale : 1:33

Copyright © 2010 Chan Pak Hei , Kade  
<http://kadechan.wix.com/portfolio>

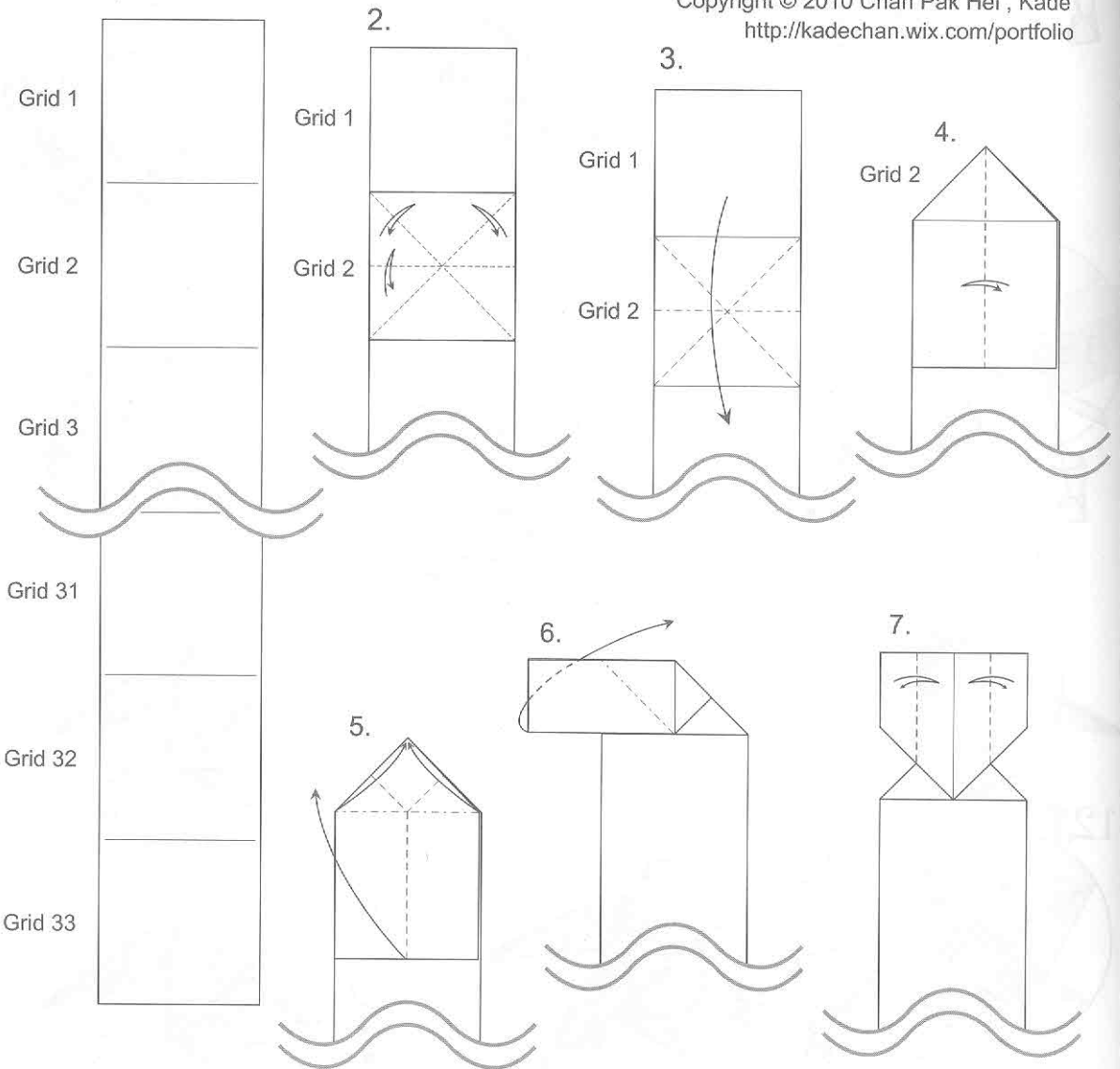

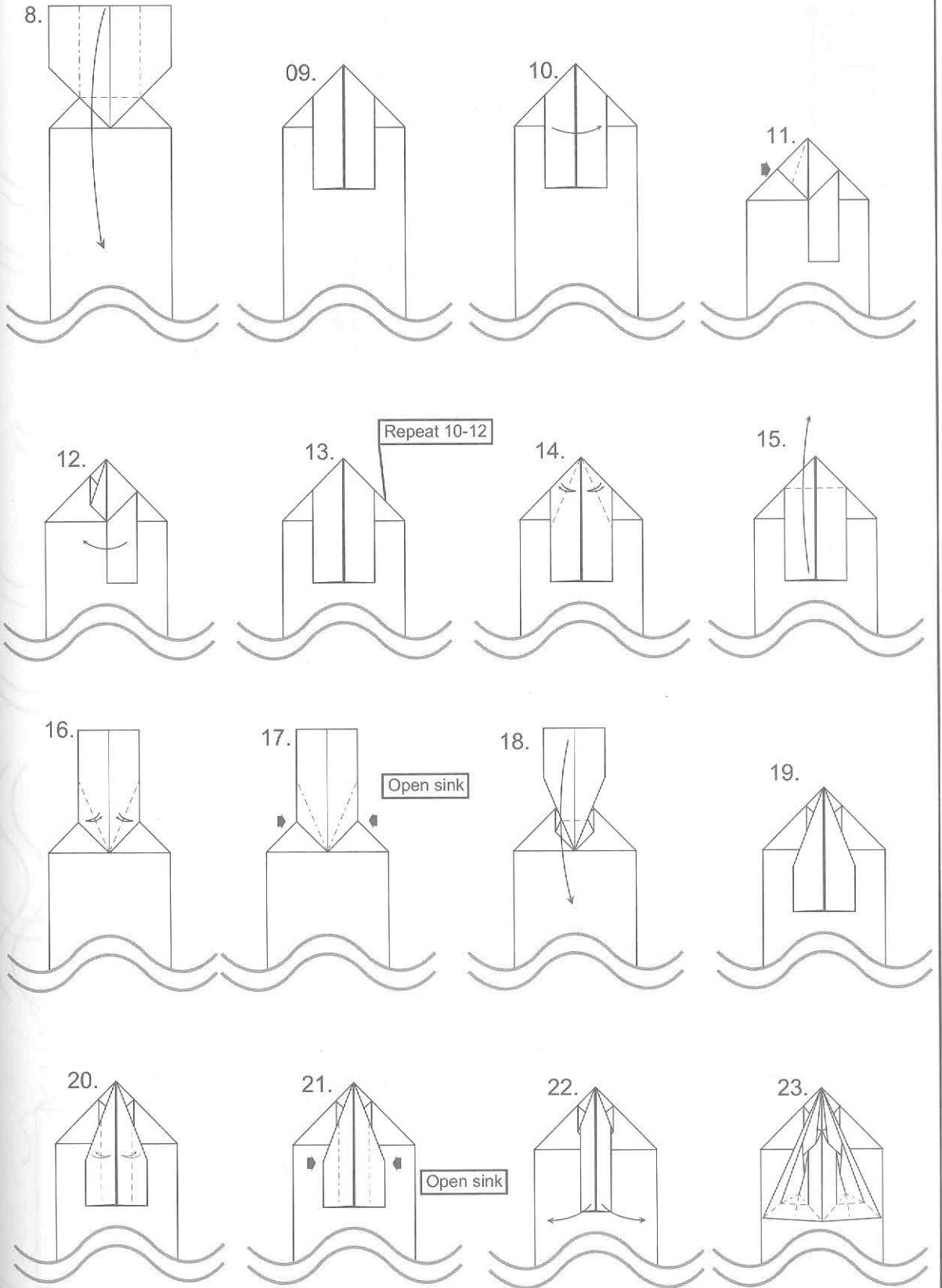

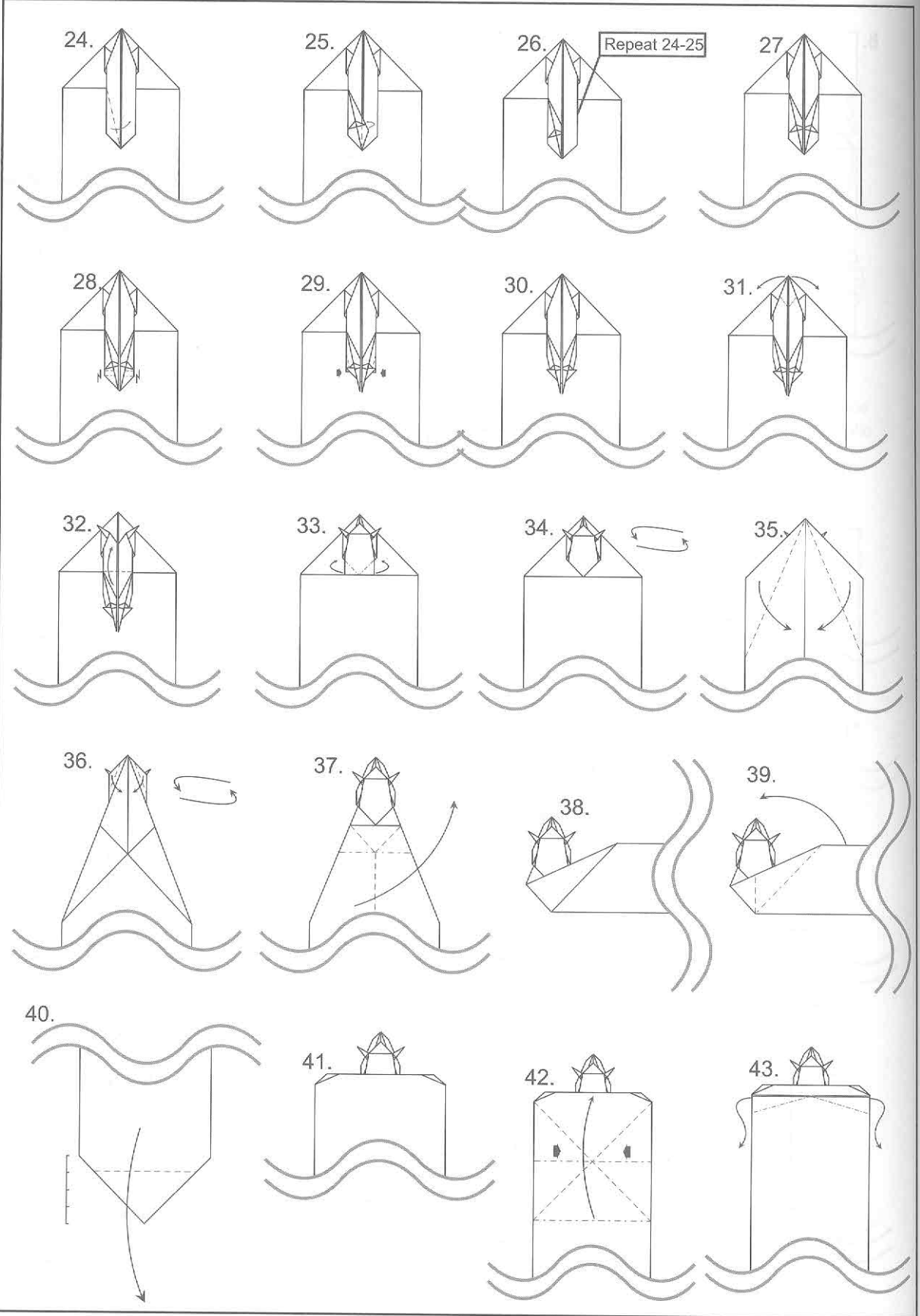

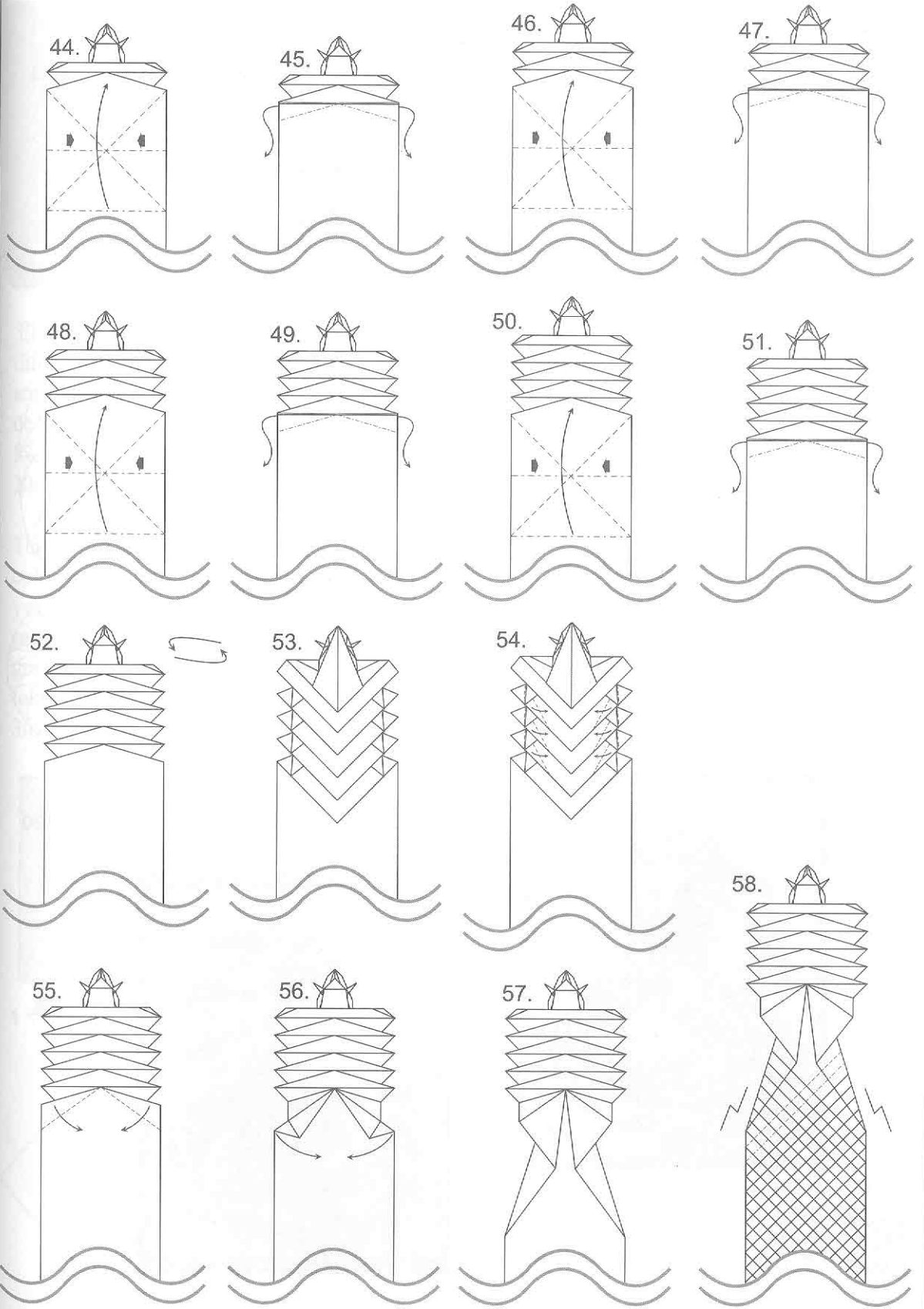

59.

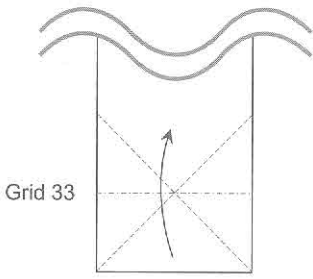

60.

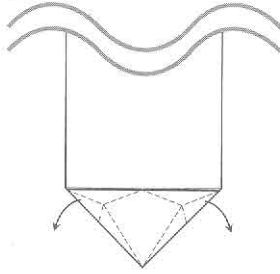

61.

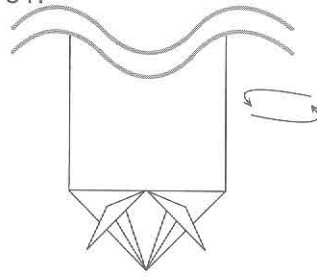

62.

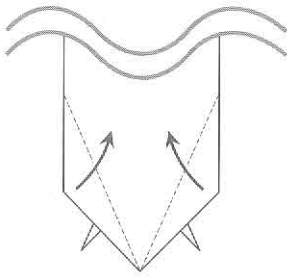

63.

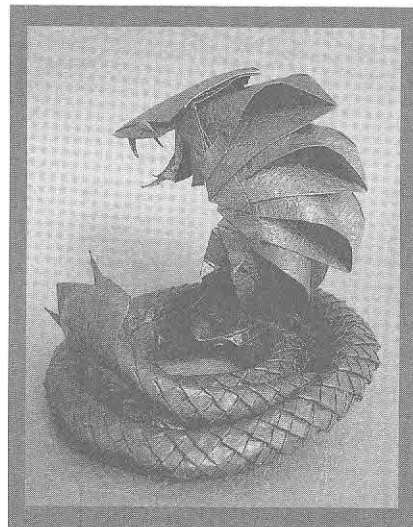
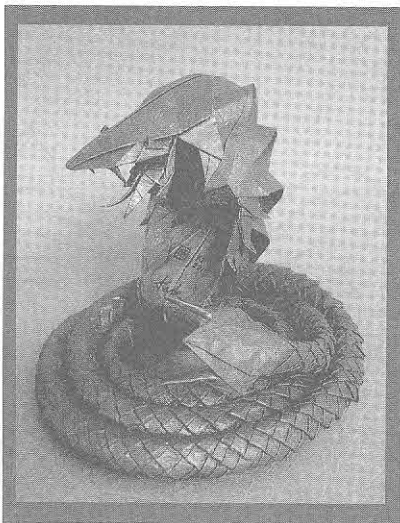
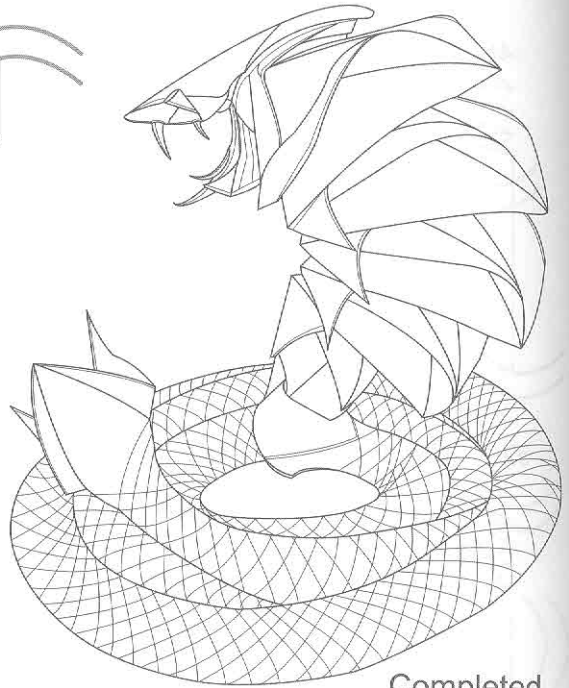
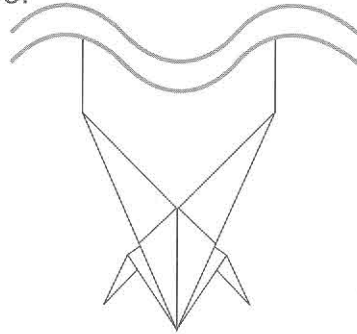

Copyright © 2010 Chan Pak Hei, Kade  
<http://kadechan.wix.com/portfolio>

# Dragonfly V. 2

(c) M. Sirgo. 2003-13

El papel puede ser de colores diferentes, azul, rojo, verde o amarillo. Se recomienda papel fino, de 20 gramos, doble seda, banana, lokta, metalizado o sandwich de 30x30 cm o mayor.

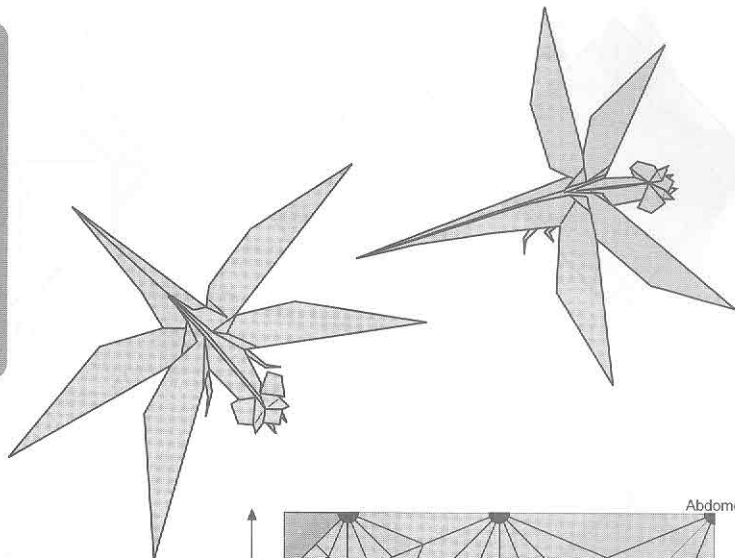

The paper can be many diferents colours like blue, red, green or yellow. Fine paper is recommended, smaller than 20 grams, double silk, banana tree, lokta, metalized or sandwich of 30x30 cm or bigger.

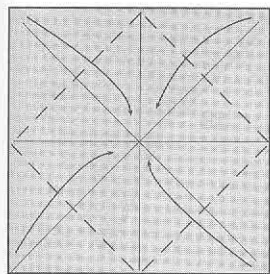
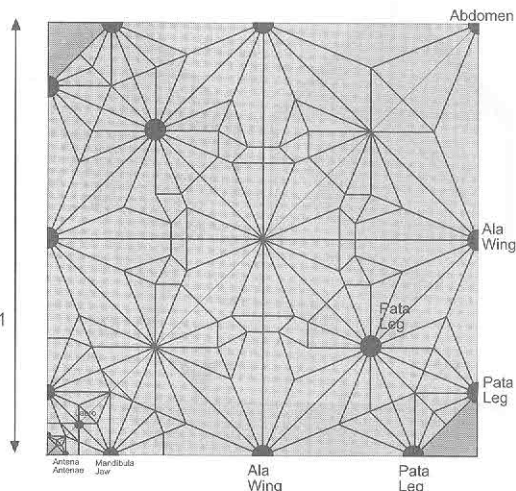
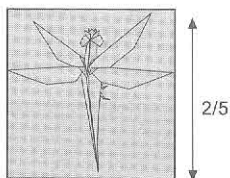

1

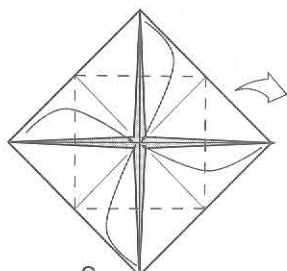

2

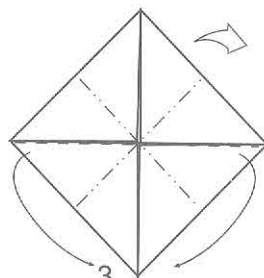

3

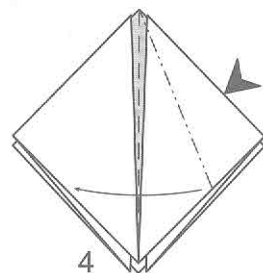

4

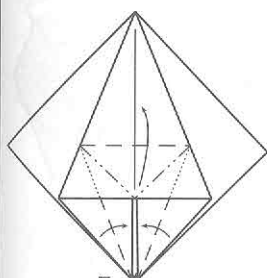

5

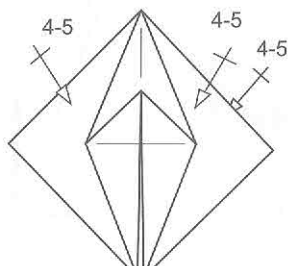

6

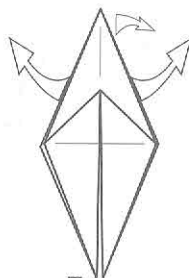

7

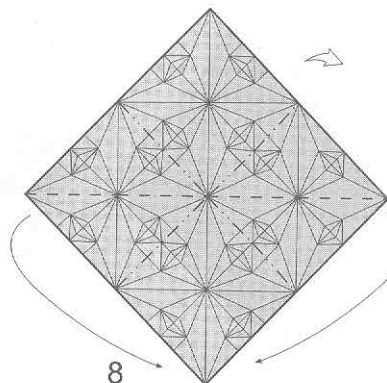

8



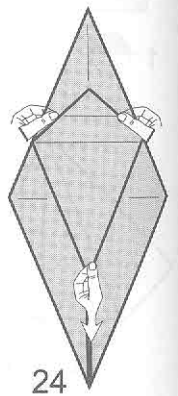
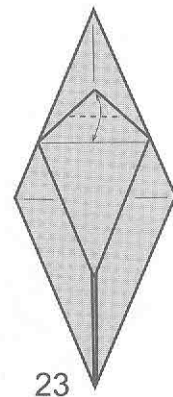
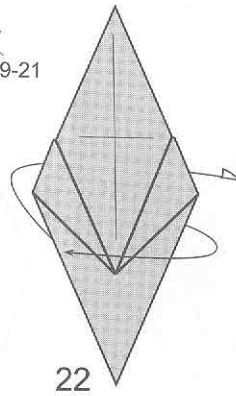
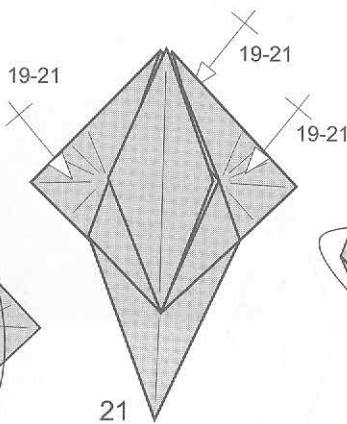
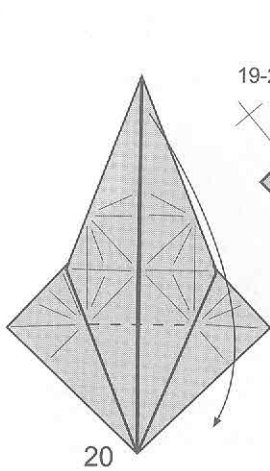
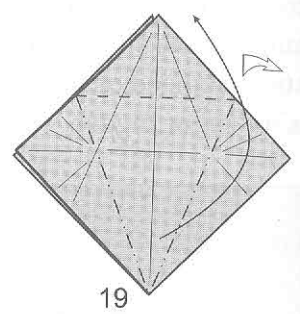
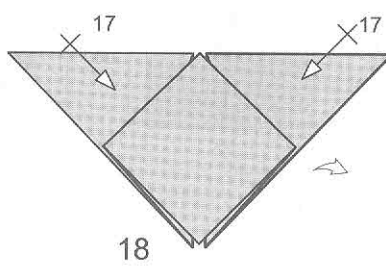
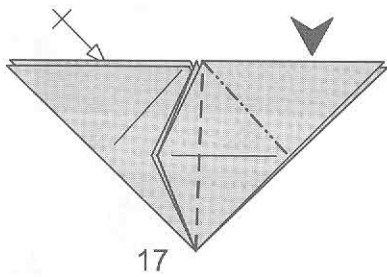
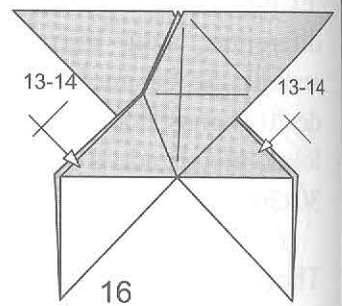
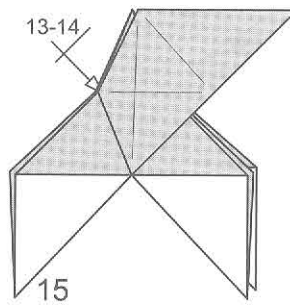
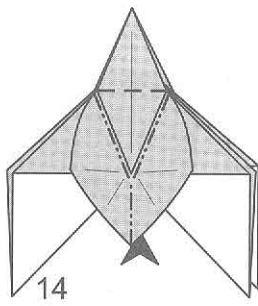
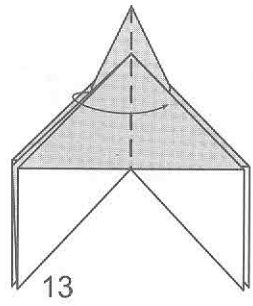
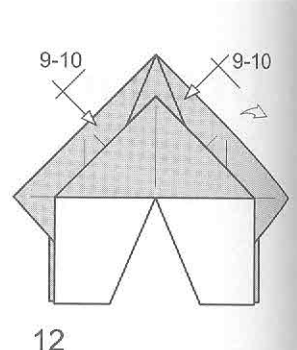
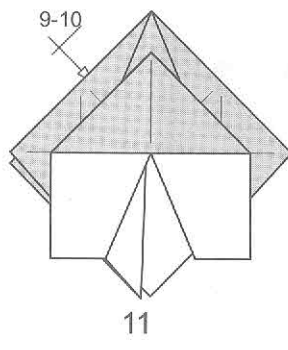
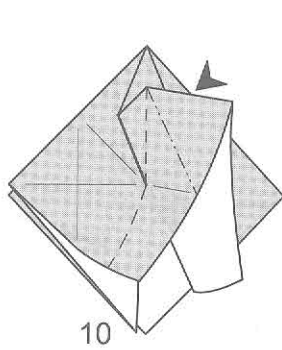
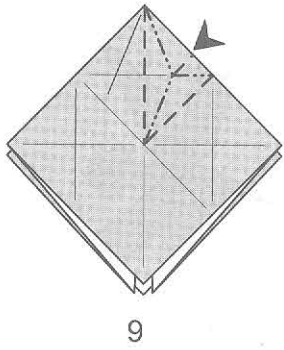

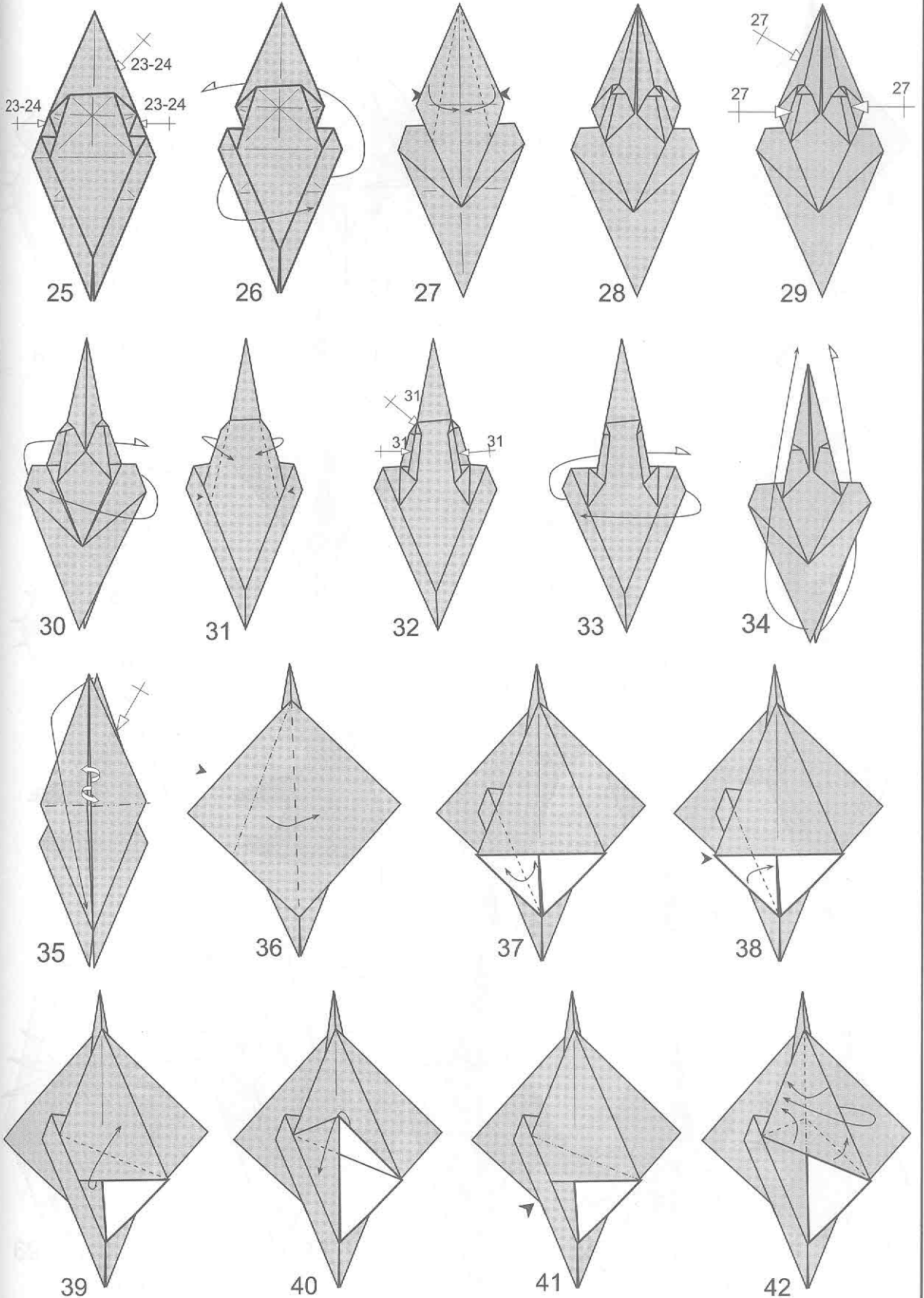

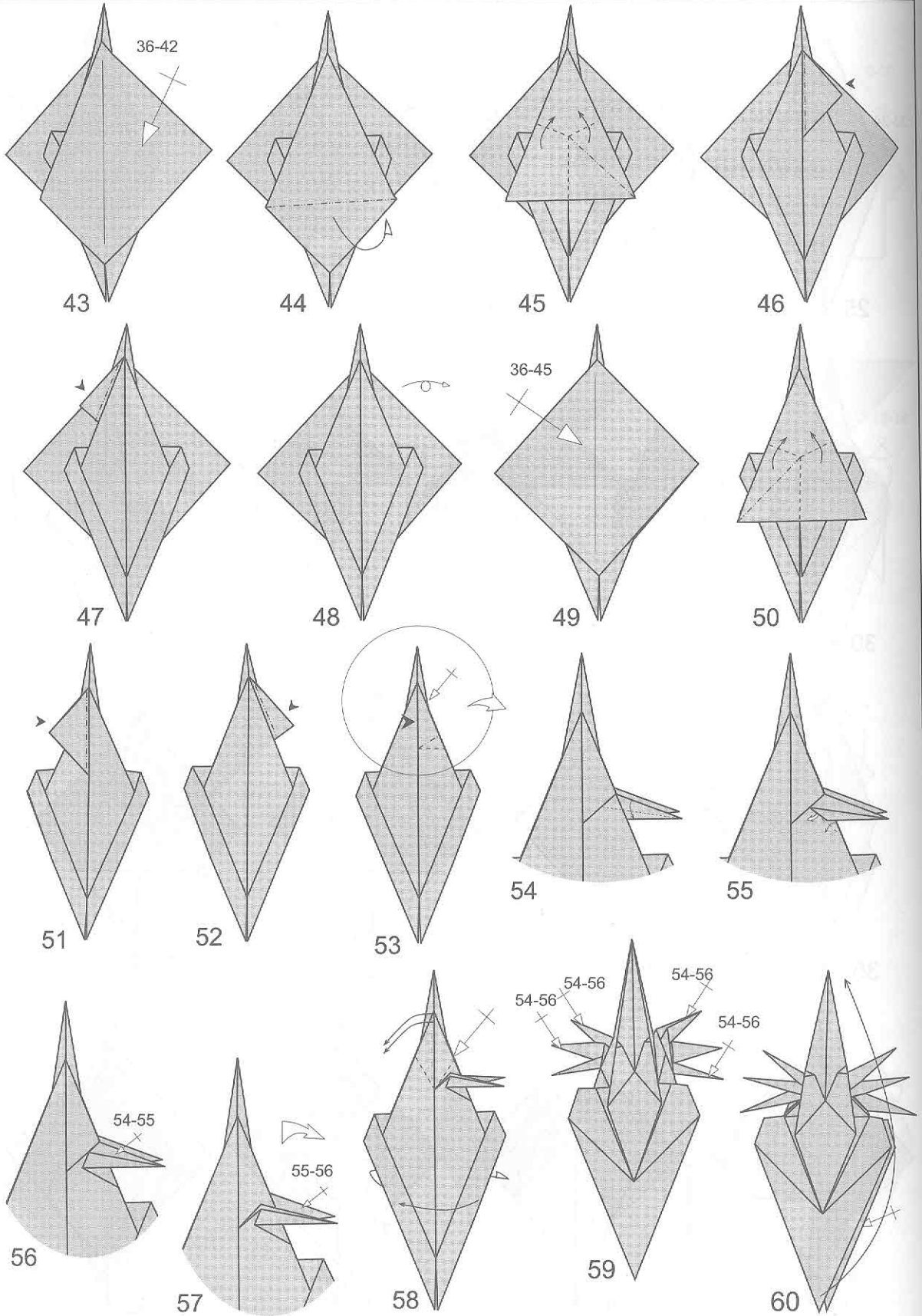

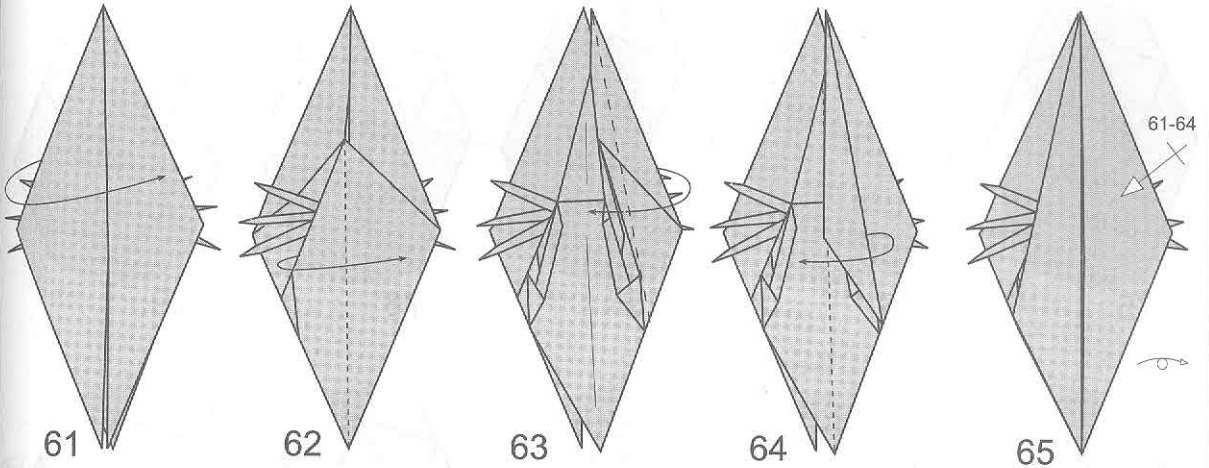

61

62

63

64

65

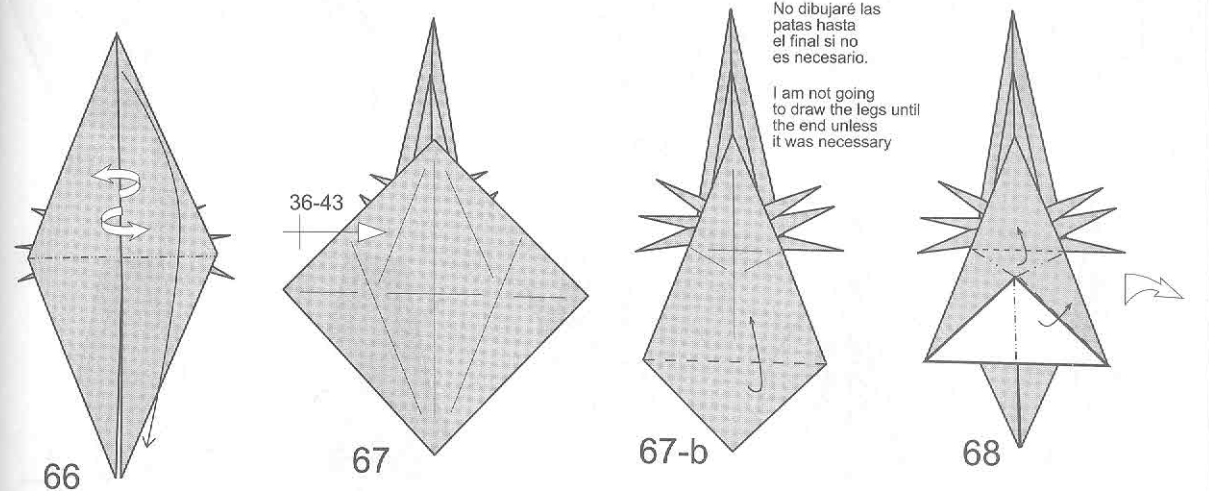

66

67

67-b

68

No dibujaré las patas hasta el final si no es necesario.

I am not going to draw the legs until the end unless it was necessary

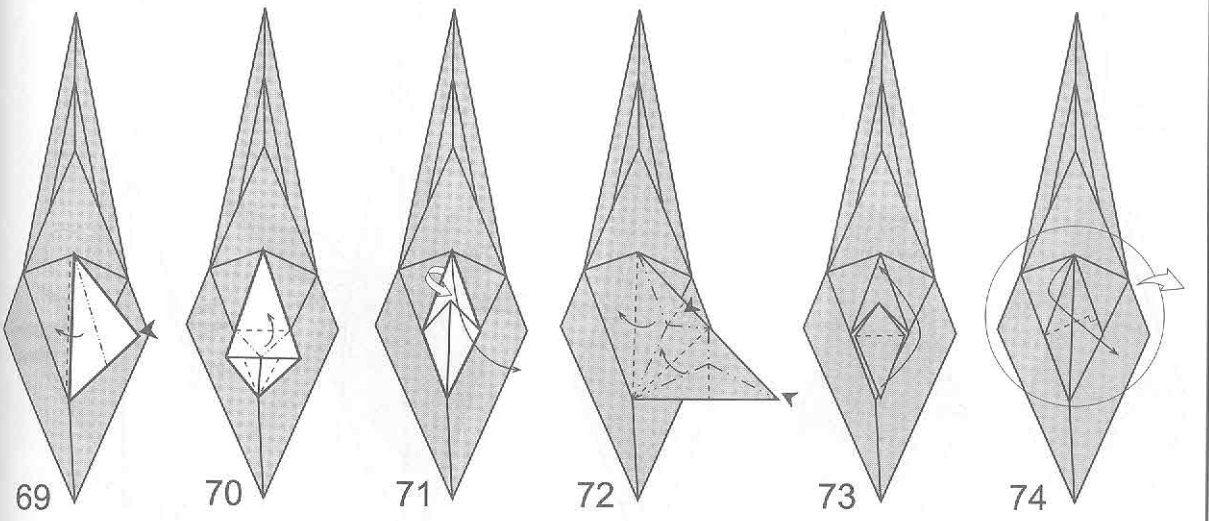

69

70

71

72

73

74

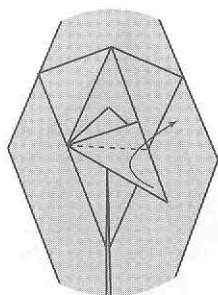

75

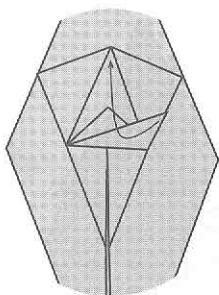

76

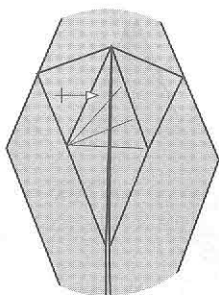

77

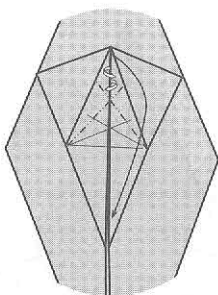

78

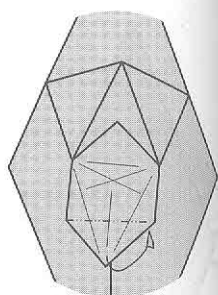

79

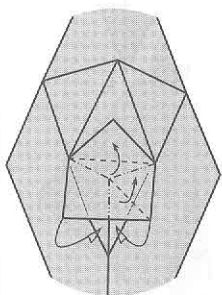

80

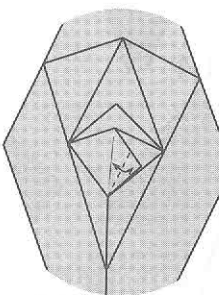

81

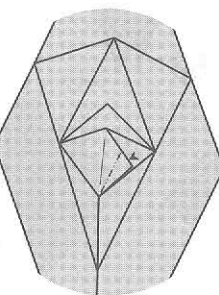

82

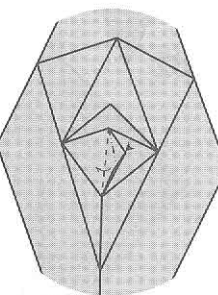

83

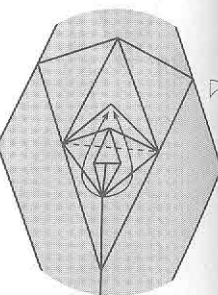

84

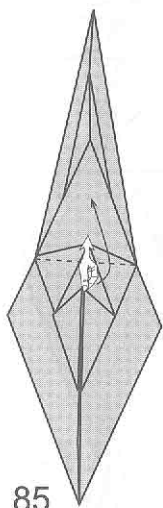

85

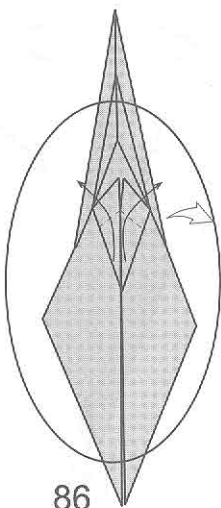

86

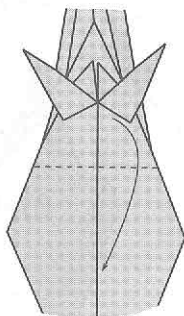

87

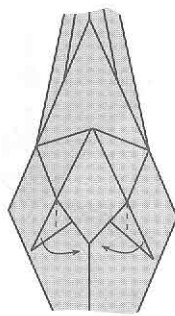

88

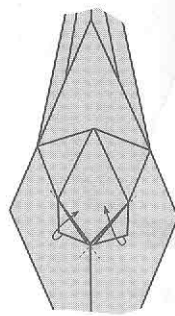

89

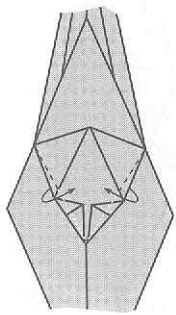

90

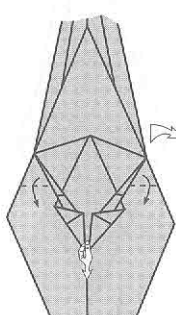

91

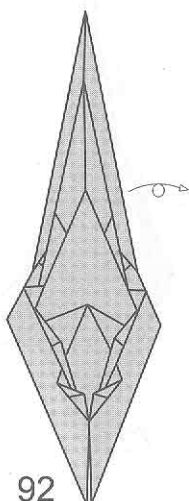

92

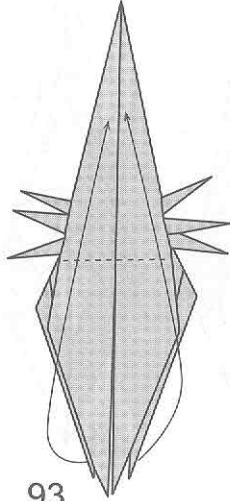

93

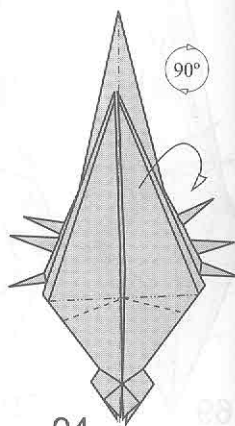

94

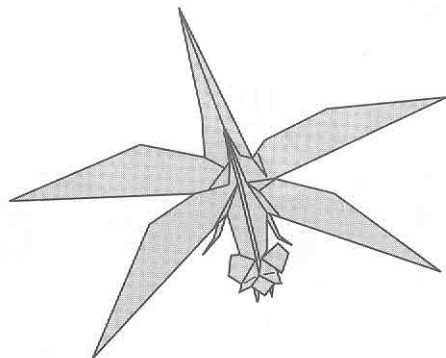
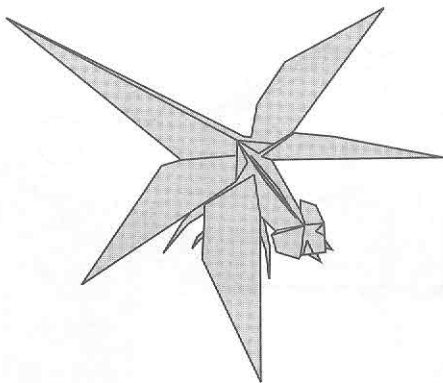
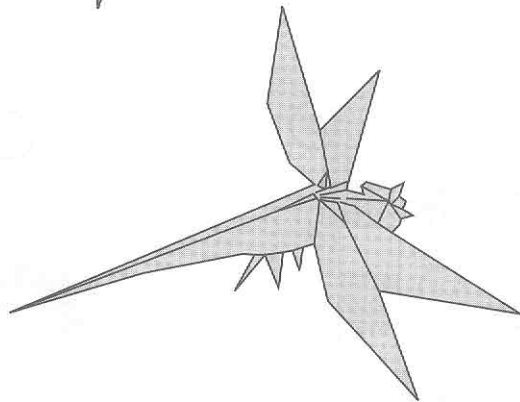
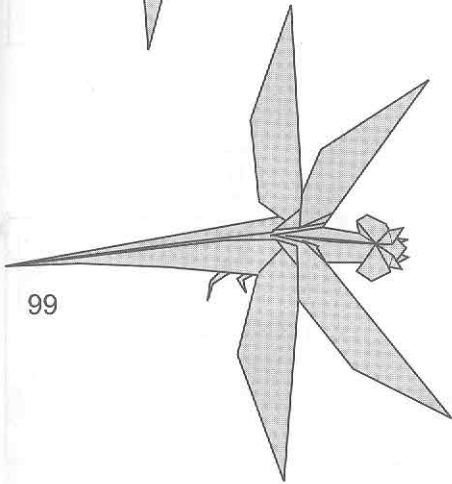
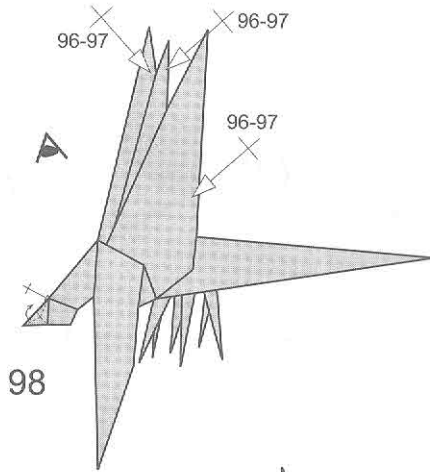
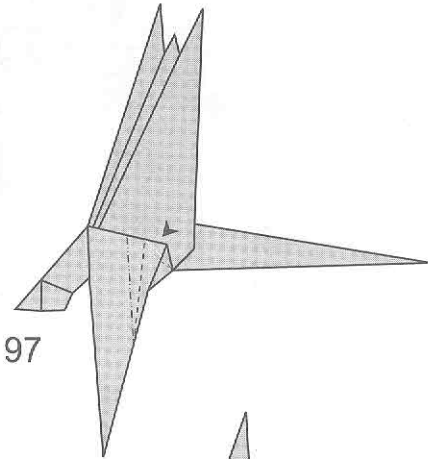
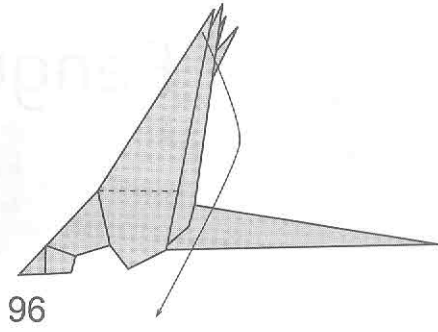
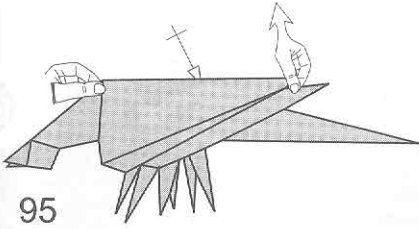

# Penguin

Hadi Tahir

Bandung, 19 Mei 2013  
<http://haditahir.wordpress.com>  
[haditahir@yahoo.com](mailto:haditahir@yahoo.com)

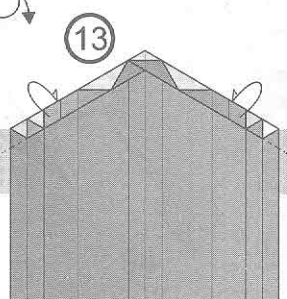
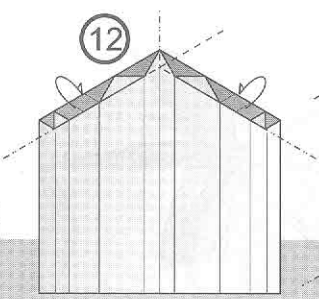
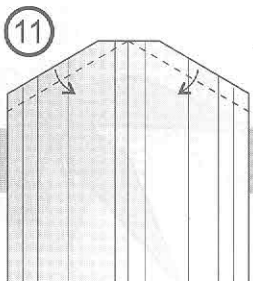
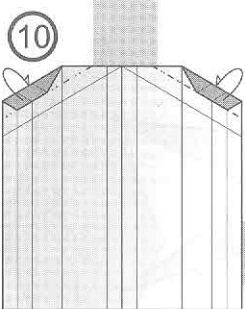
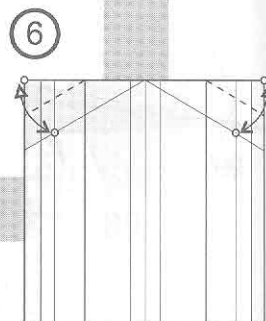
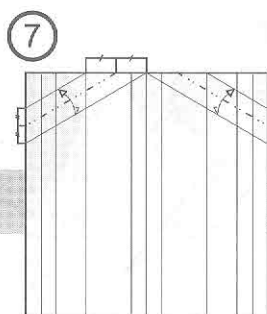
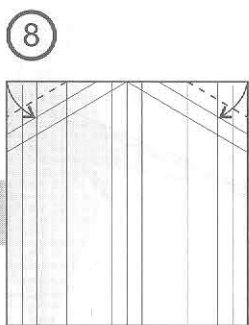
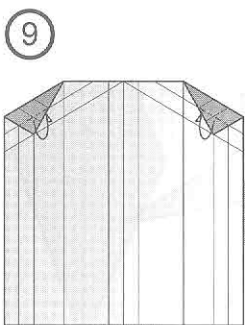
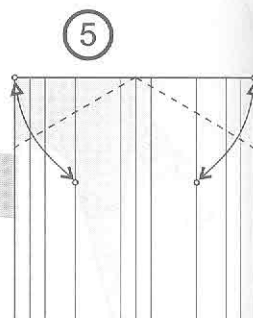
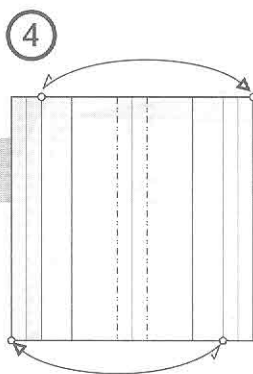
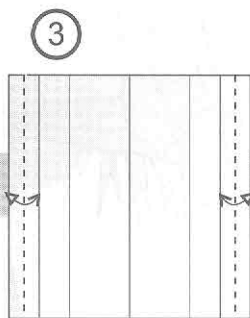
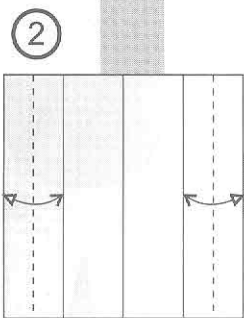
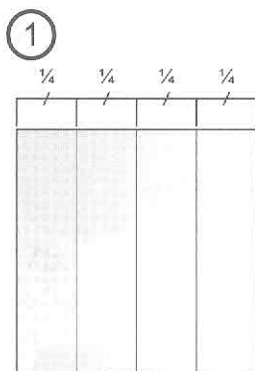
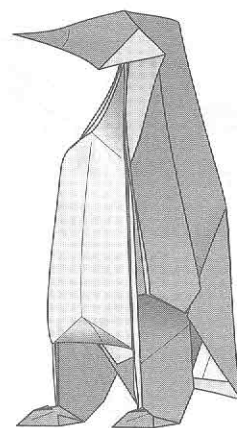

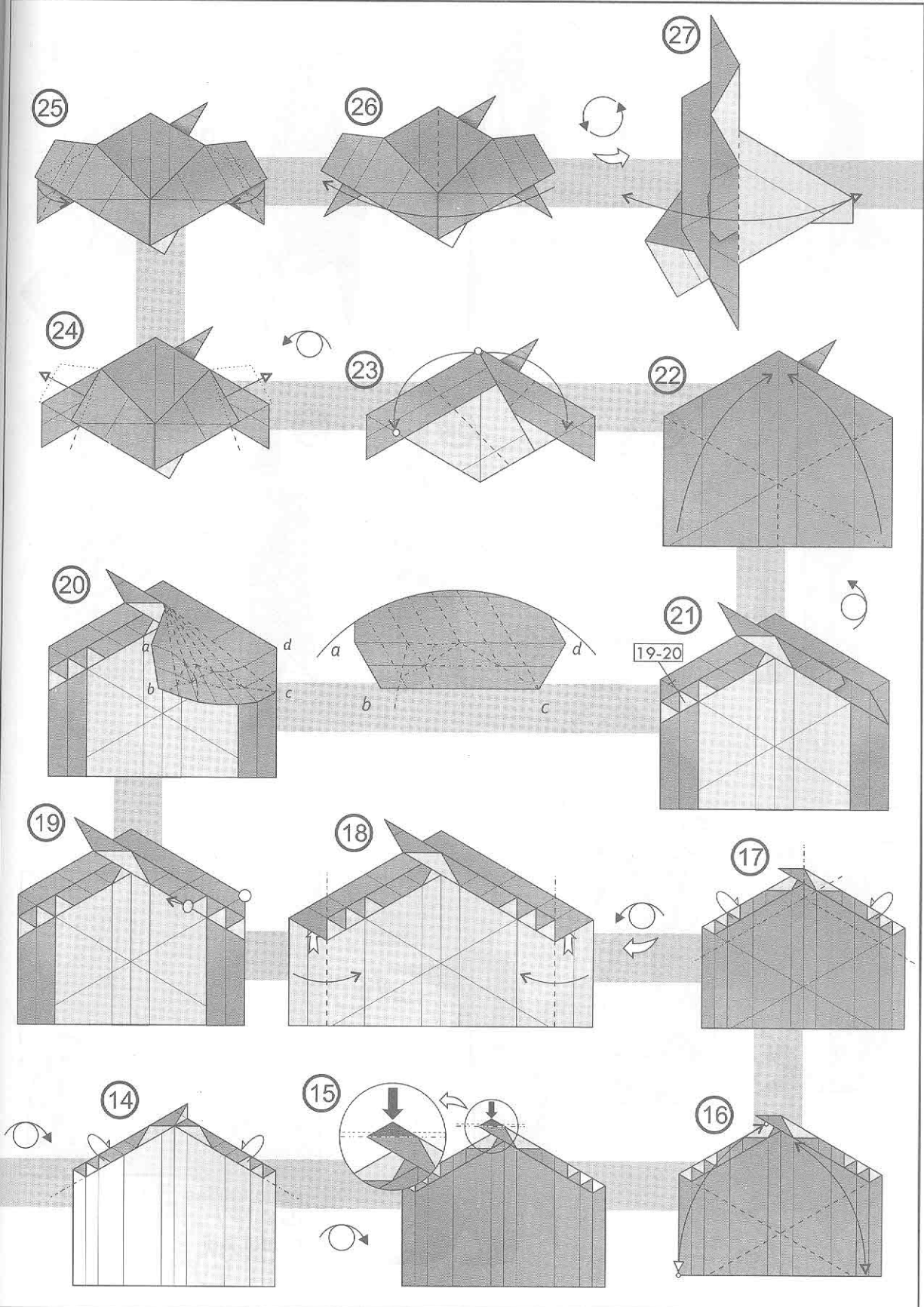





# Pingwin / Penguin

Designed by Blanka Pentela 2011  
Diagrammed by Artur Biernacki 2011

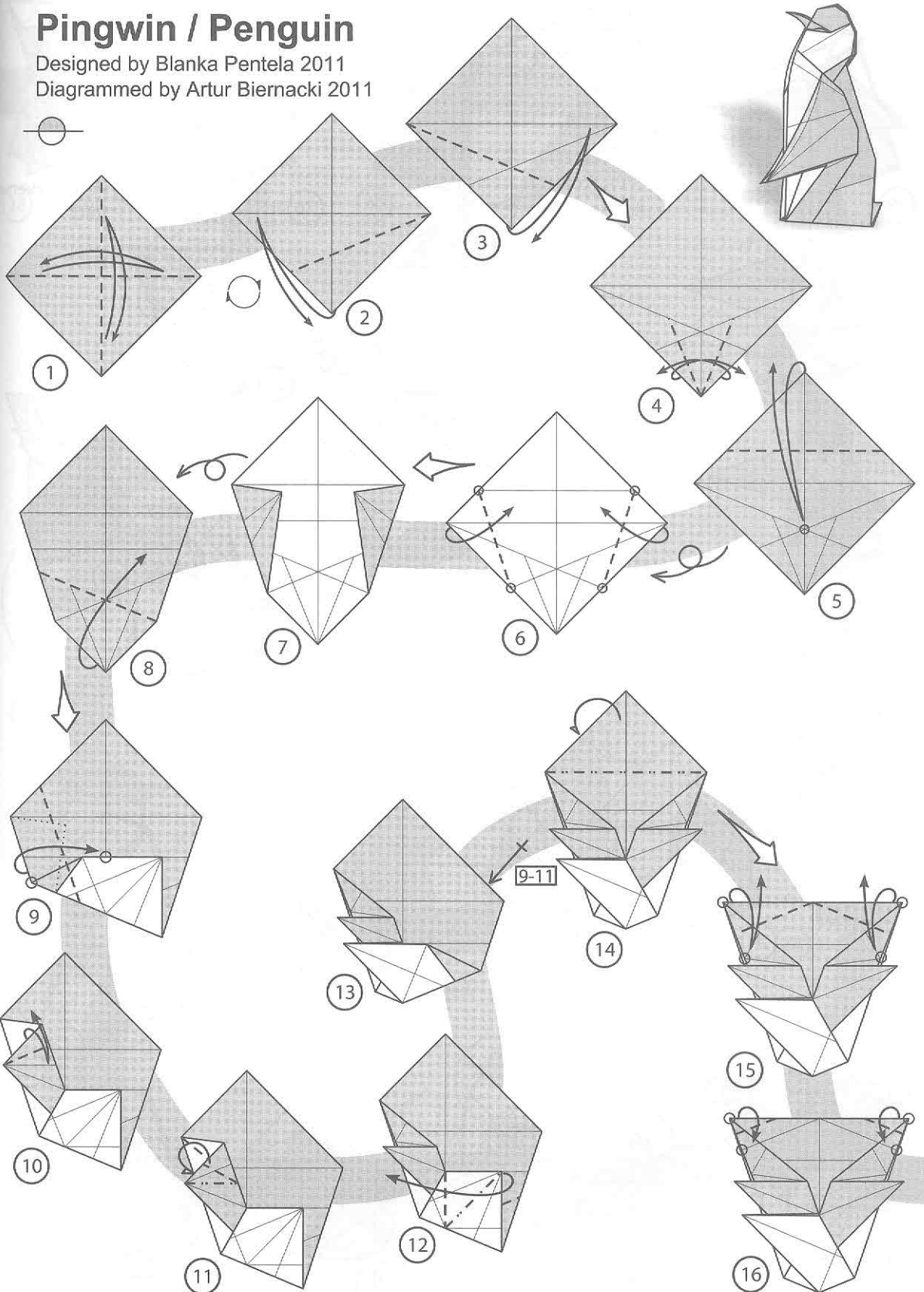

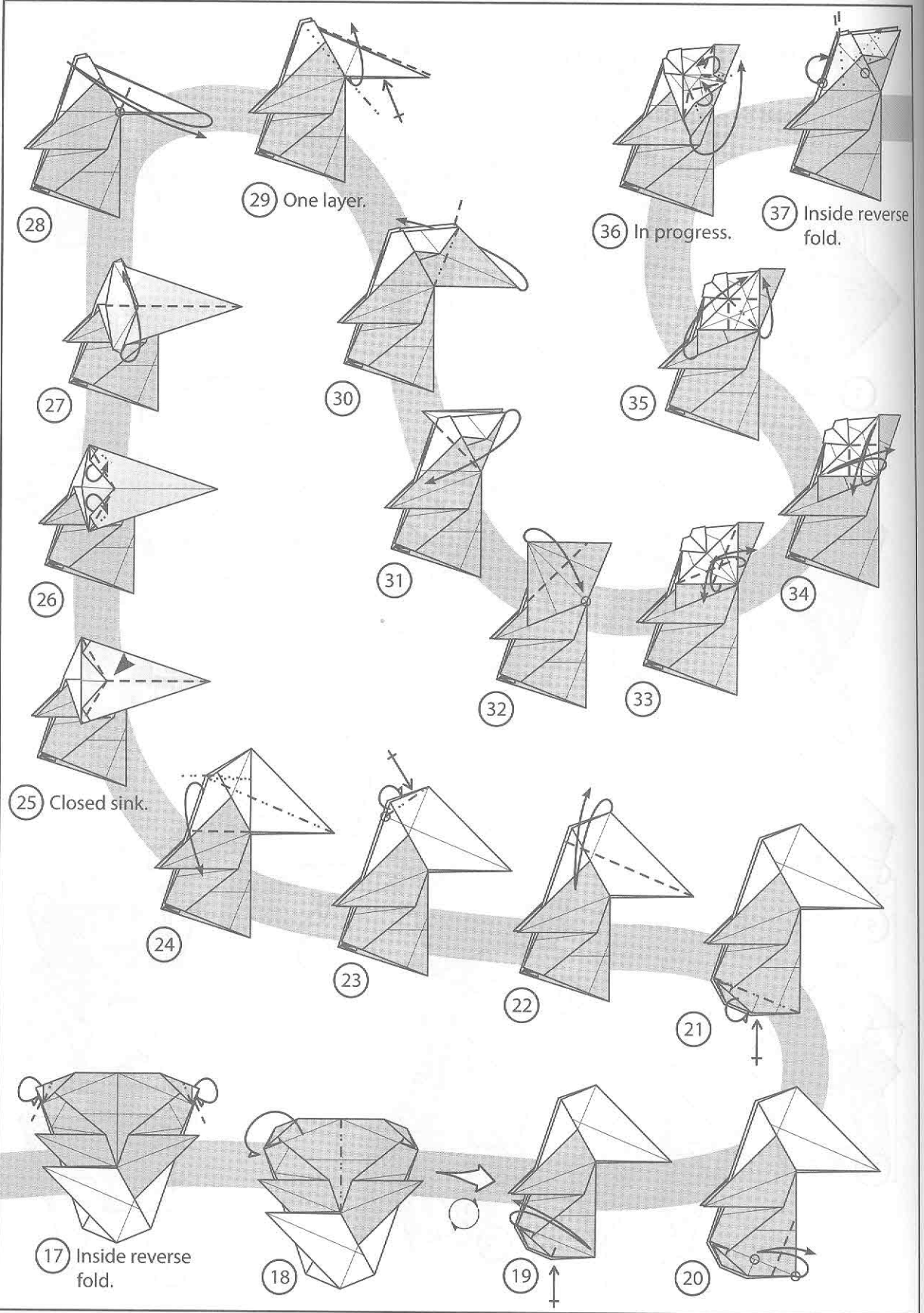

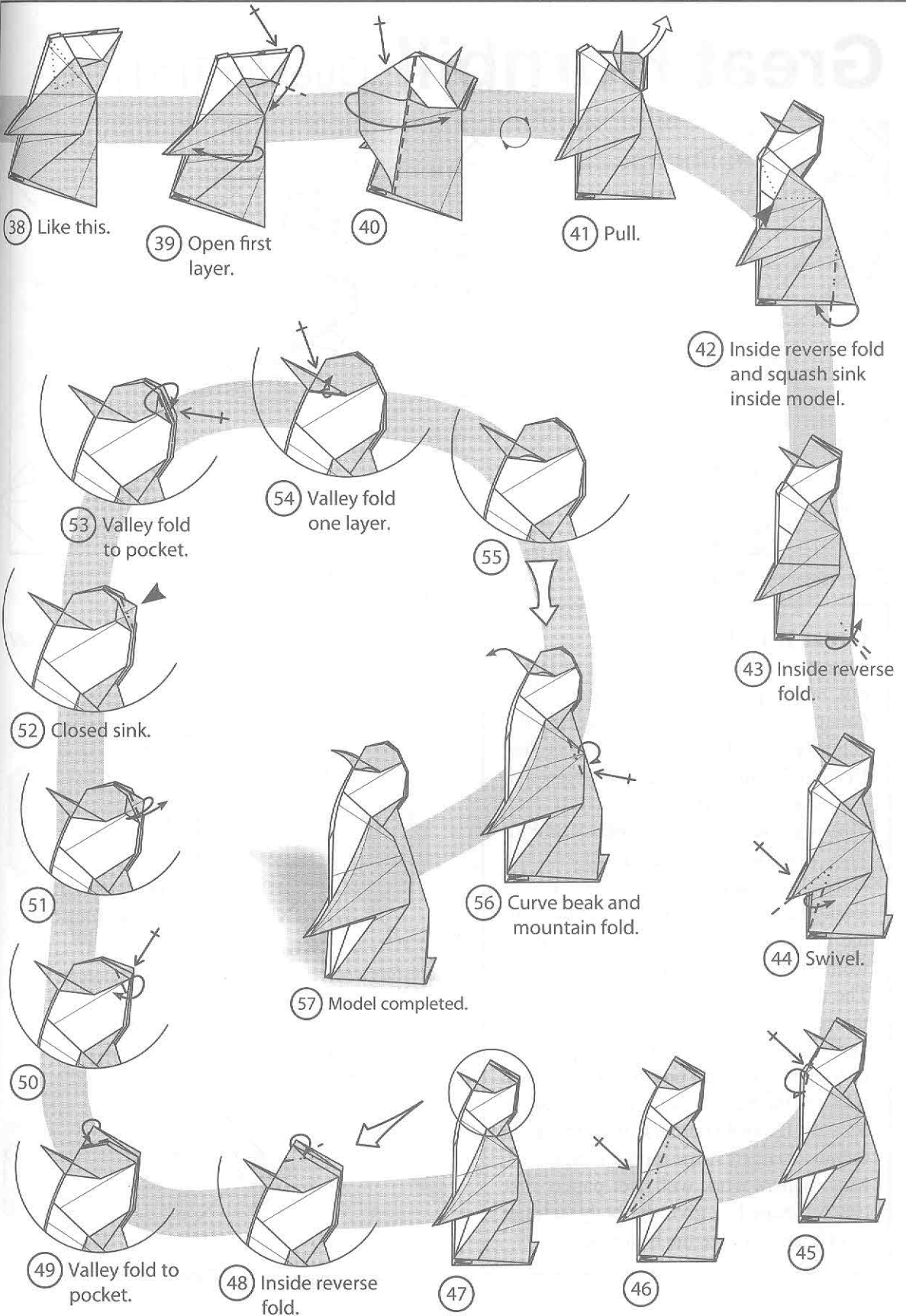

# Great Hornbill Quentin Trollip

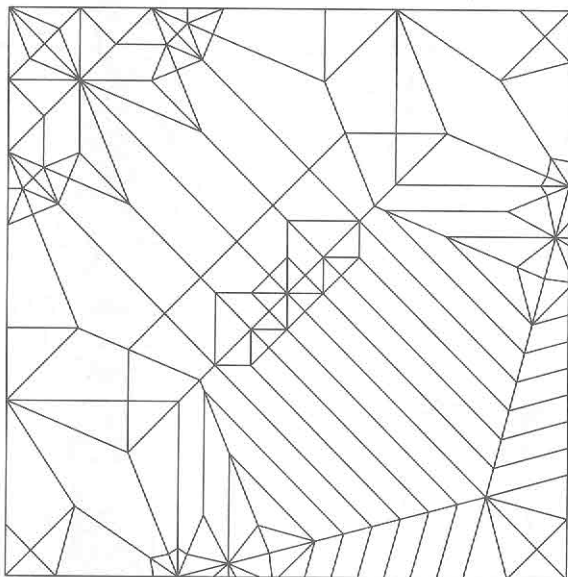

Date created: 1 October 2011

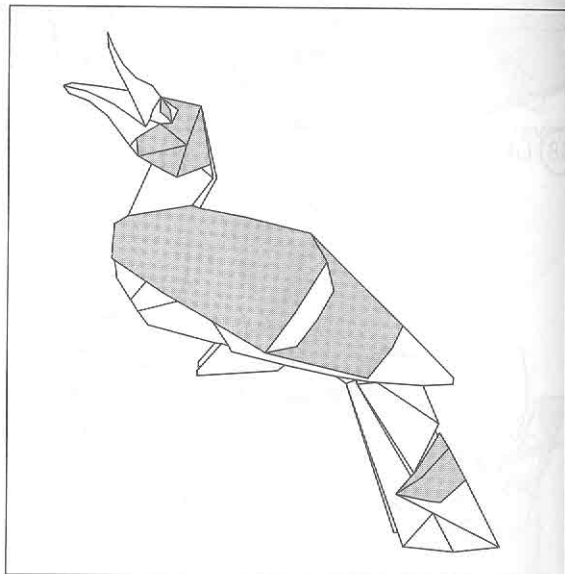

Recommended size and ratio: 35cm gives 19cm height

## Great Hornbill

There are many different types of Hornbill, but I wanted to specifically design a Great Hornbill, sometimes also called a “Great Indian Hornbill”, or a “Great Pied Hornbill”, which is one of the largest and most spectacular Hornbills.

This is my second version of a Hornbill. The first version did not have the coloured stripe on the wings, so I had to totally redesign it. In order to achieve all the colour-changes, the feet are folded from the center of the paper.

The vertical graft (step 15 to 18) thus has three functions: To split the central flap and separate the two feet (steps 30 to 36), to lengthen the tail and to supply more paper to the head area to fold the casque. The two opposite corners are used for the colour-changed stripe on the wings.

Most papers work well, but papers that can be shaped to give the body volume (wet-shaping) give the best results.

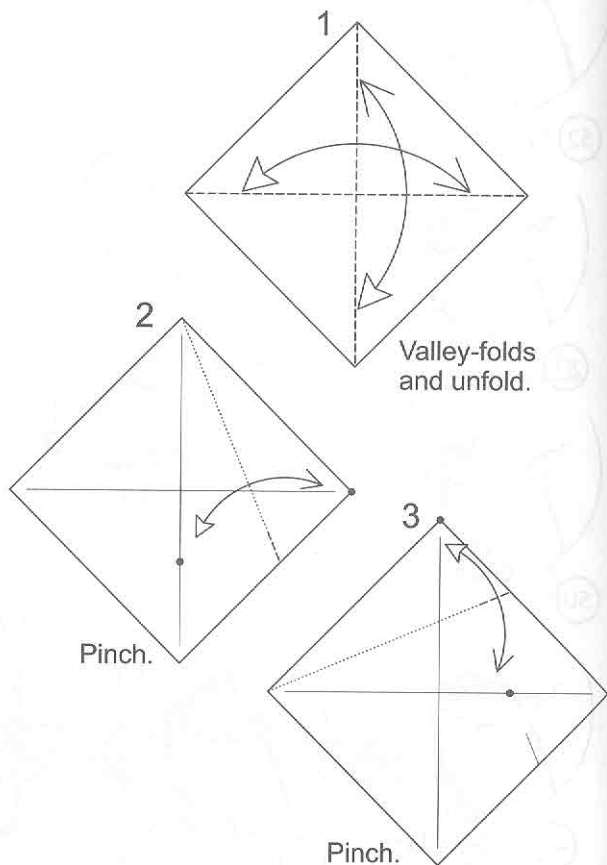

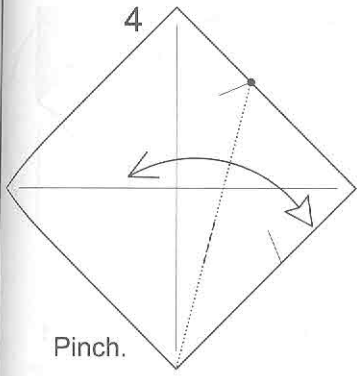

Pinch.

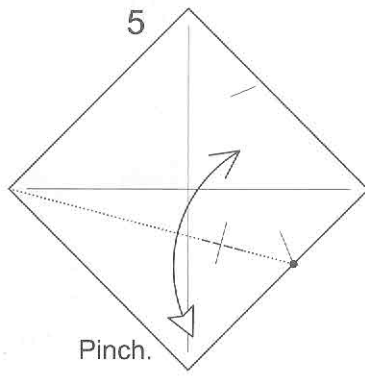

Pinch.

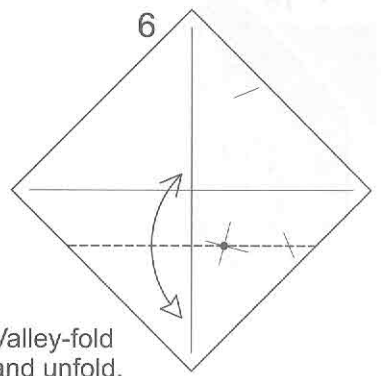

Valley-fold and unfold.

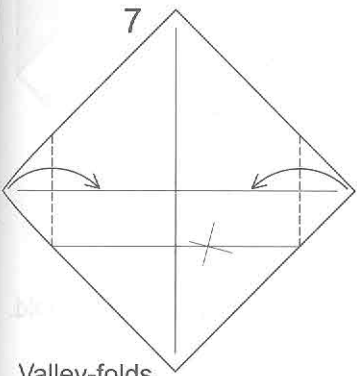

Valley-folds.

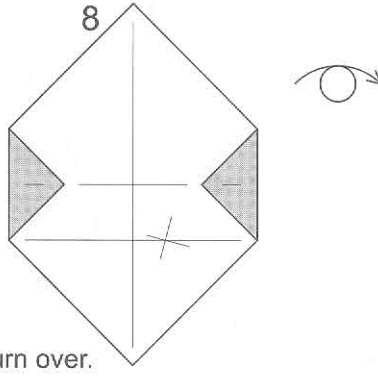

Turn over.

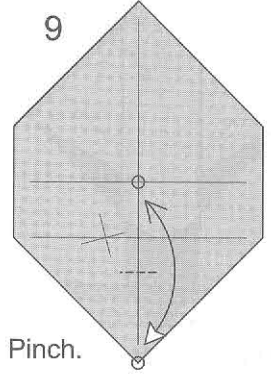

Pinch.

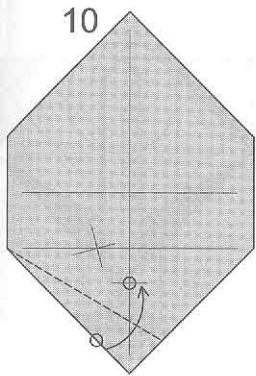

Valley-fold.

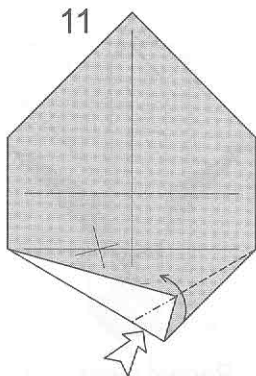

Inside reverse-fold.

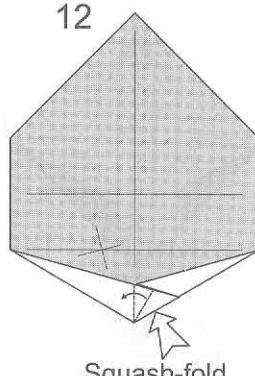

Squash-fold.

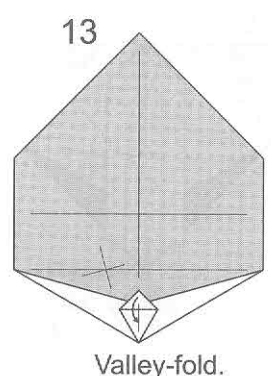

Valley-fold.

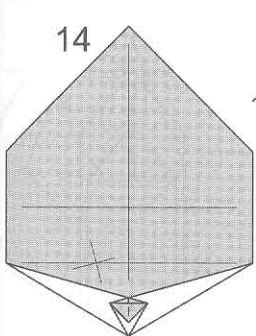

Turn over.

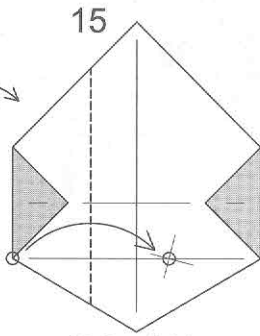

Valley-fold.

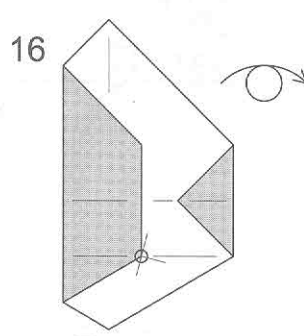

Turn over.

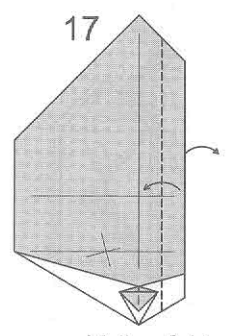

Valley-fold.

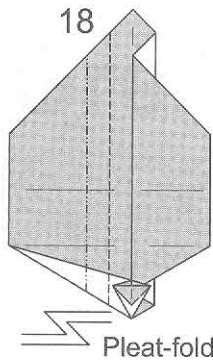

Pleat-fold.

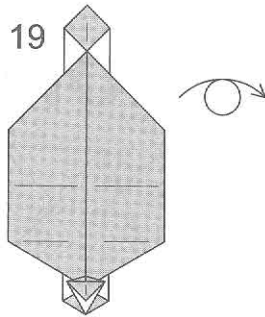

Turn over.

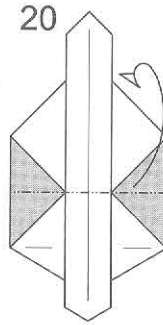

Mountain-fold.

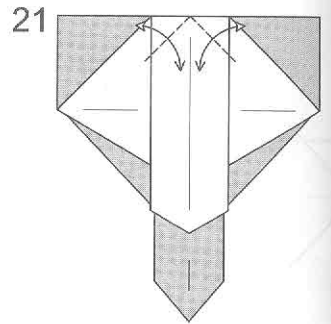

Valley-folds and unfold.

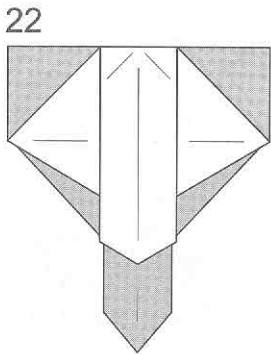

Unfold to step 15.

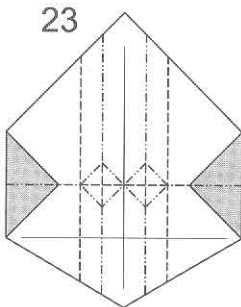

Collapse on existing creases.

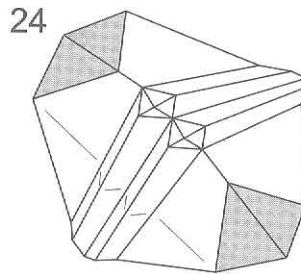

In progress. Flatten.

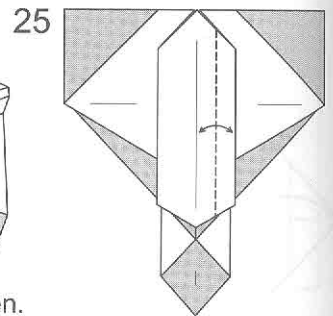

Valley-fold and unfold.

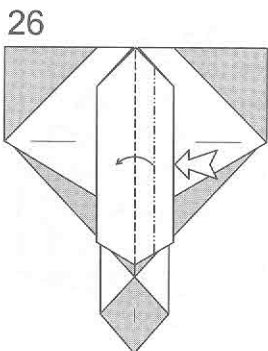

Spread-squash.

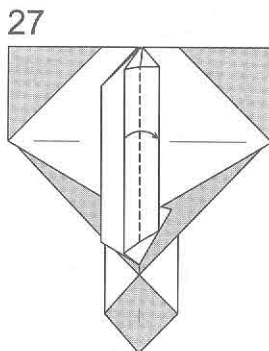

Valley-fold.

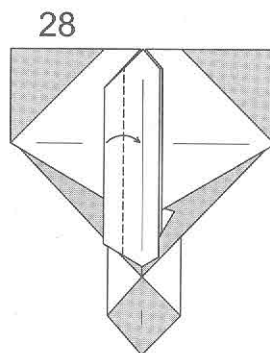

Repeat steps 25 to 27 on the left.

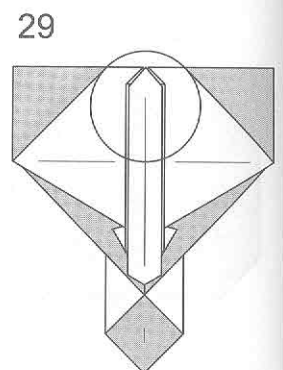

Enlarge.

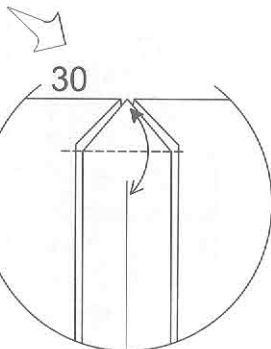

Valley-fold and unfold.

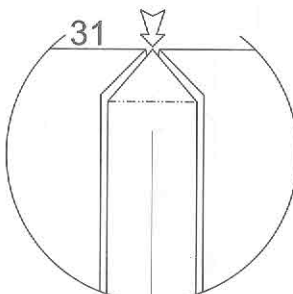

Open-sink.

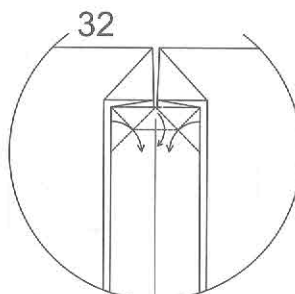

Swivel-fold.

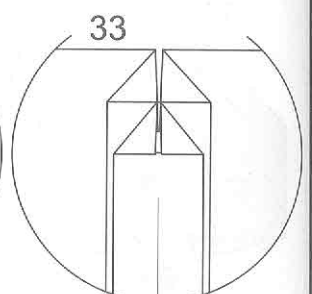

Turn over.

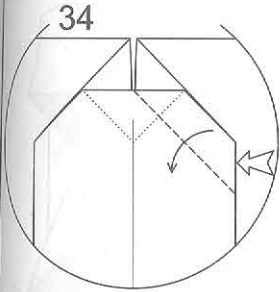

34

Spread-squash.

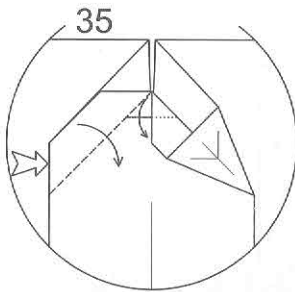

35

Spread-squash.

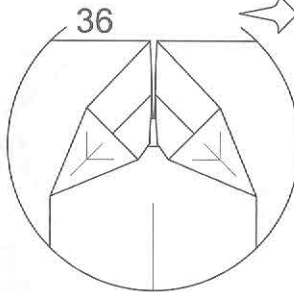

36

Scale change.

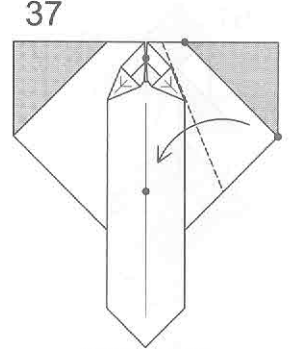

37

Valley-fold.

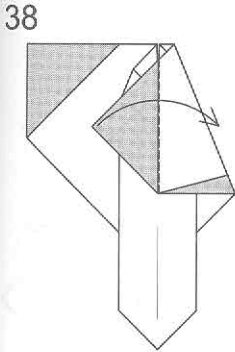

38

Valley-fold.

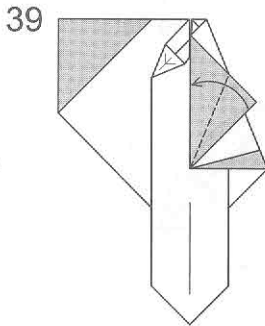

39

Valley-fold.

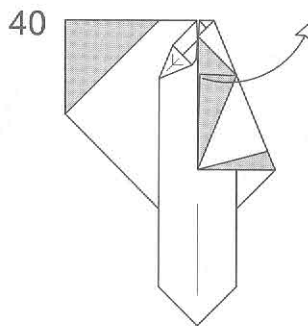

40

Unfold.

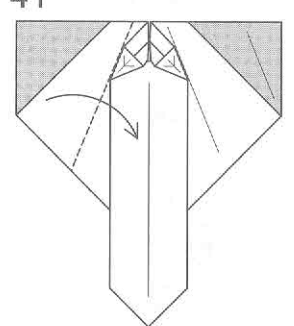

41

Repeat steps 37 to 40 on the left.

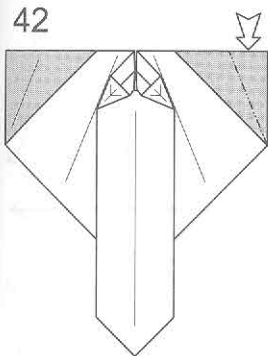

42

Inside reverse-fold.

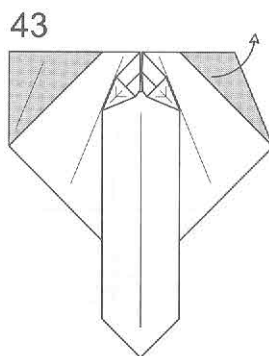

43

Unfold the raw corner.

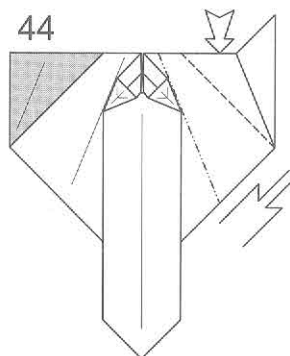

44

Crimp-fold in and out.

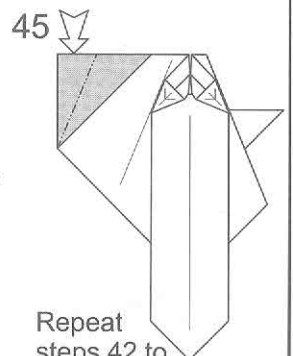

45

Repeat steps 42 to 44 on the left.

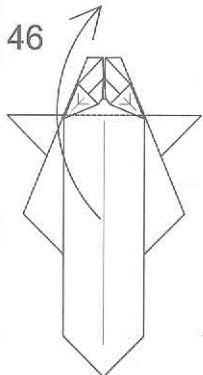

46

Valley-fold.

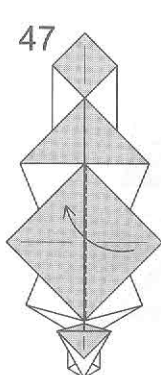

47

Lift the raw edge.

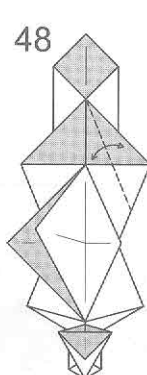

48

Valley-fold and unfold.

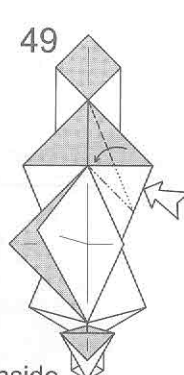

49

Inside reverse-fold.

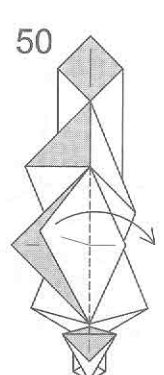

50

Flatten.



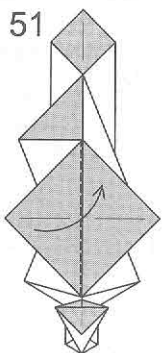

Repeat steps 47 to 50 on the left.

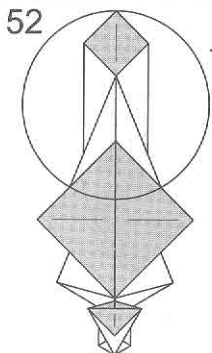

Enlarge.

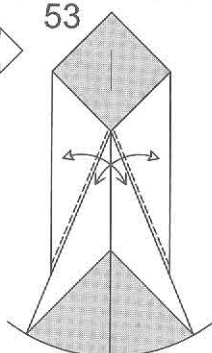

Valley-folds and unfold.

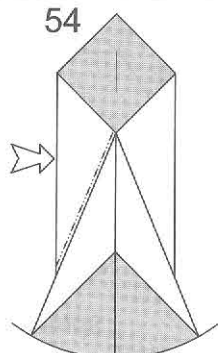

Inside reverse-fold. The model will not lie flat.

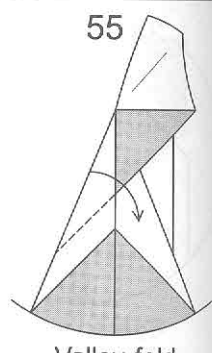

Valley-fold.

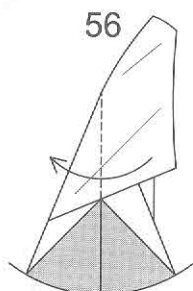

Valley-fold.

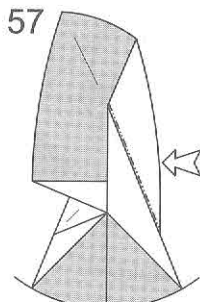

Repeat steps 54 to 56 on the right.

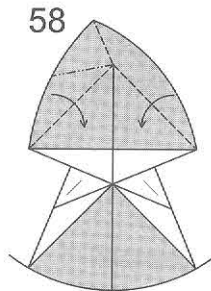

Squash-fold to flatten.

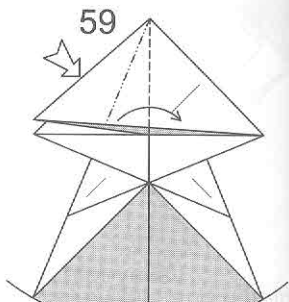

Squash-fold.

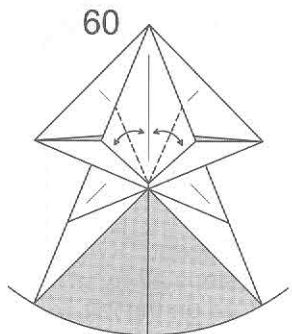

Valley-folds and unfold.

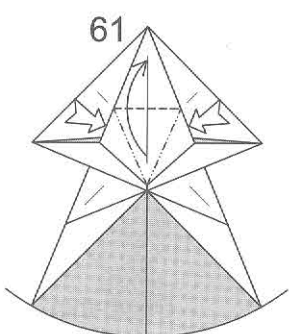

Petal-fold.

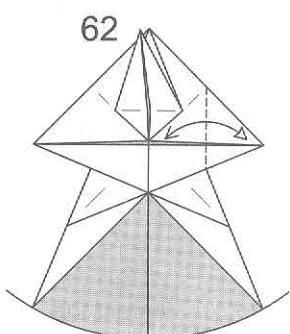

Valley-fold and unfold.

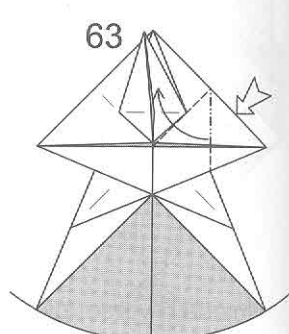

Squash-fold.

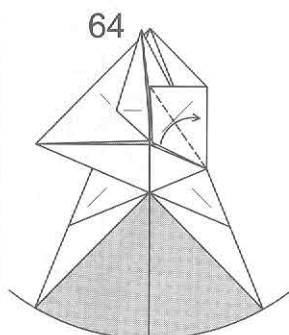

Valley-fold.

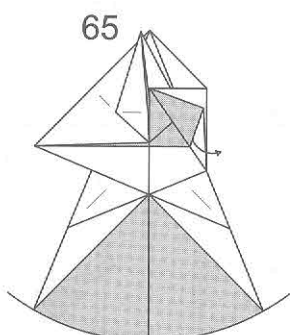

Unfold the raw edge.

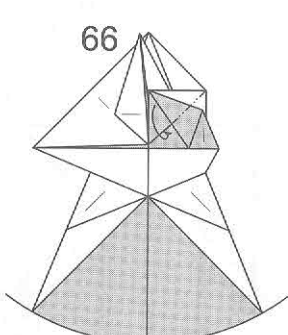

Place the point under.

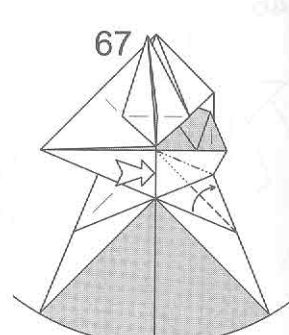

Inside reverse-fold.

68

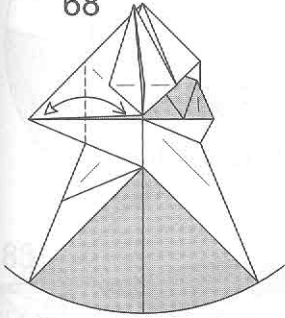

Repeat steps 62 to 67 on the left.

69

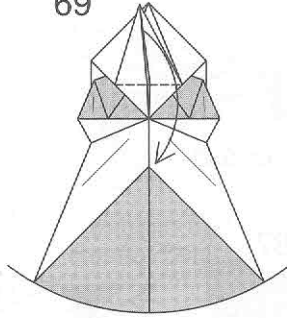

Valley-fold.

70

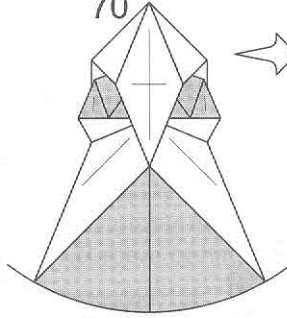

Scale change.

71

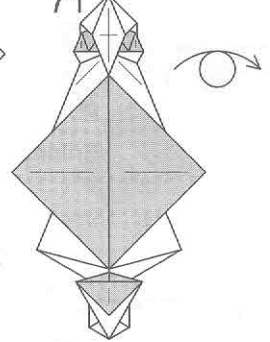

Turn over.

72

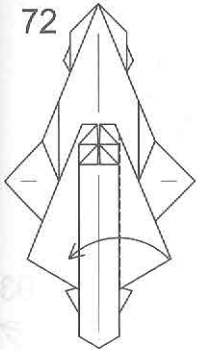

Valley-fold.

73

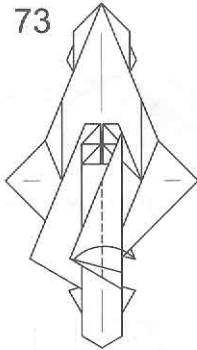

Valley-fold.

74

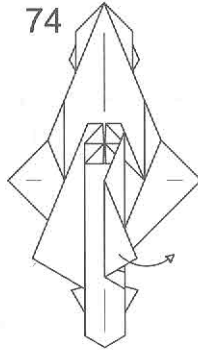

Unfold.

75

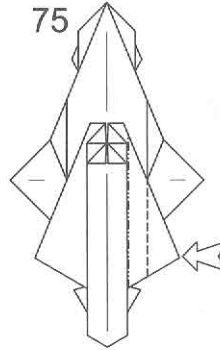

Reverse-fold in and out.

76

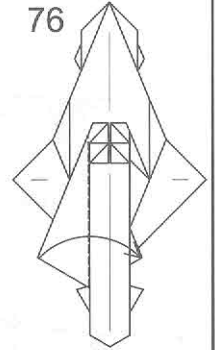

Repeat steps 72 to 75 on the left.

77

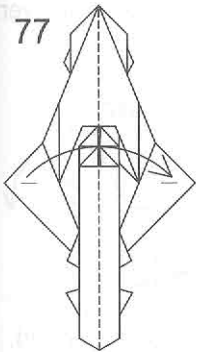

Valley-fold in half and rotate.

78

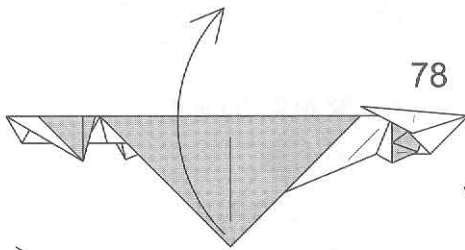

Valley-fold up.

79

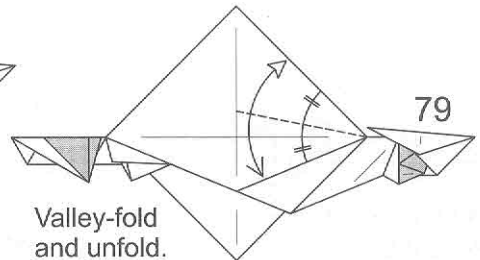

Valley-fold and unfold.

80

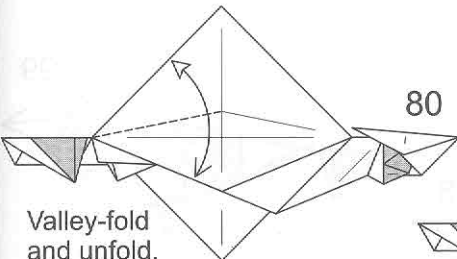

Valley-fold and unfold.

81

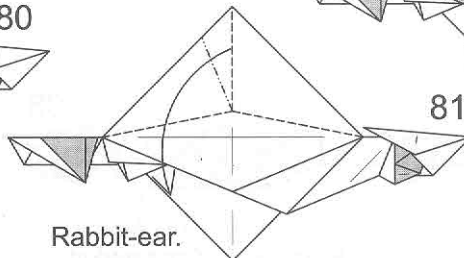

Rabbit-ear.

82

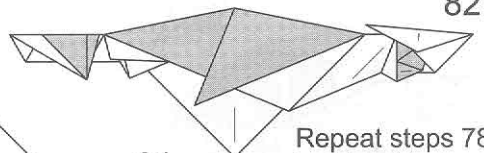

Repeat steps 78 to 81 behind.

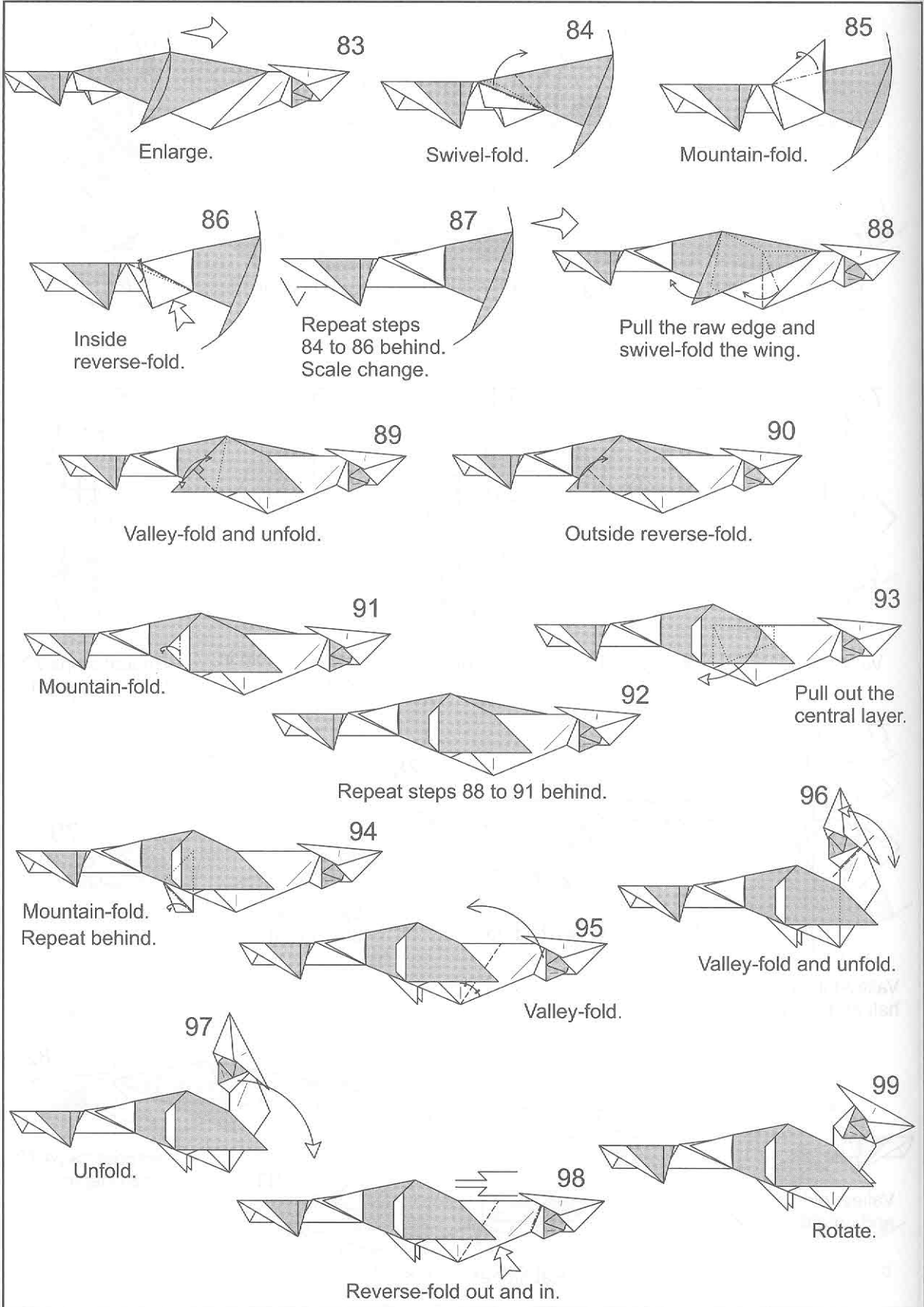

Enlarge.

Swivel-fold.

Mountain-fold.

Inside reverse-fold.

Repeat steps 84 to 86 behind. Scale change.

Pull the raw edge and swivel-fold the wing.

Valley-fold and unfold.

Outside reverse-fold.

Mountain-fold.

Pull out the central layer.

Repeat steps 88 to 91 behind.

Mountain-fold. Repeat behind.

Valley-fold and unfold.

Valley-fold.

Unfold.

Rotate.

Reverse-fold out and in.

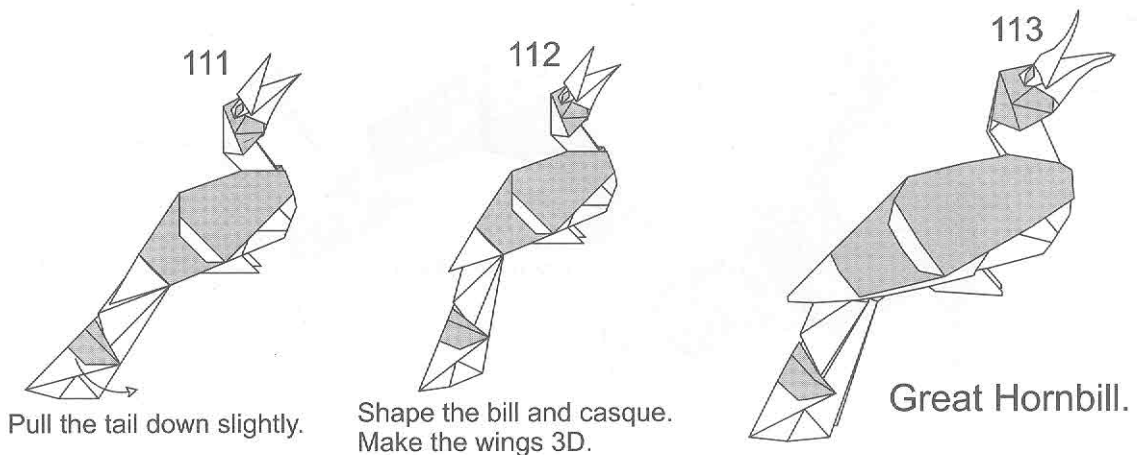
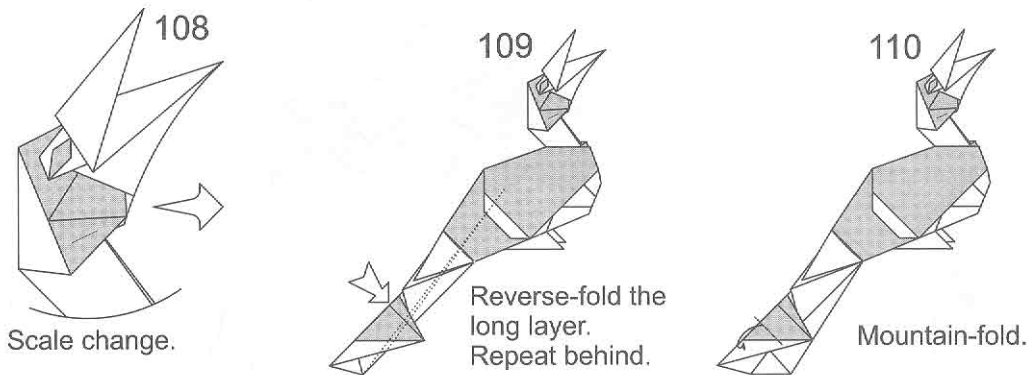
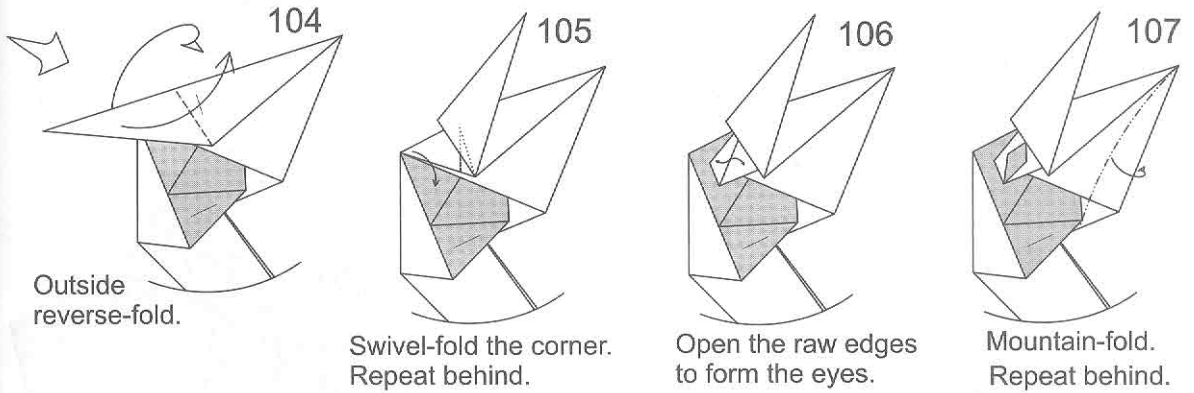
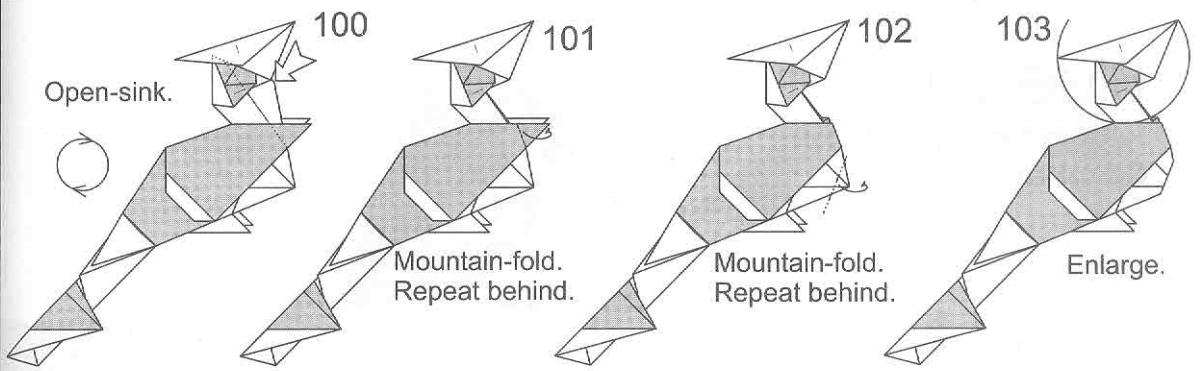

# Blue Jay

Hoang Tien Quyet  
October 2012

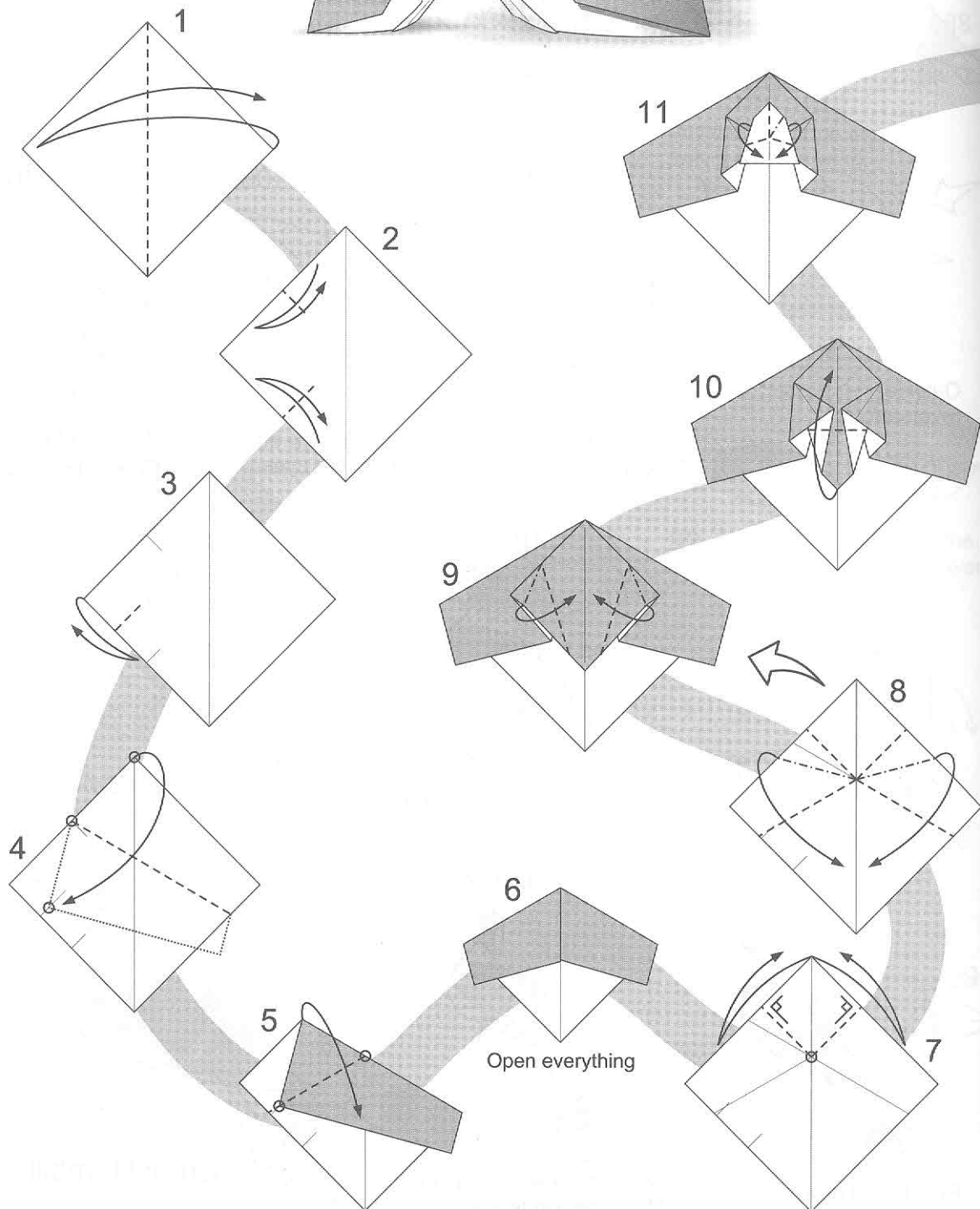
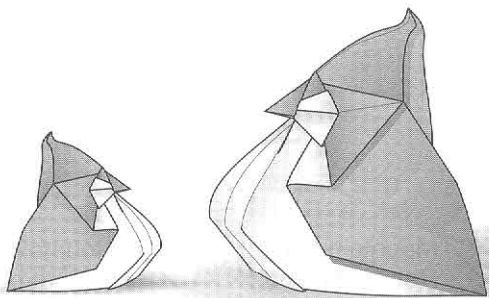

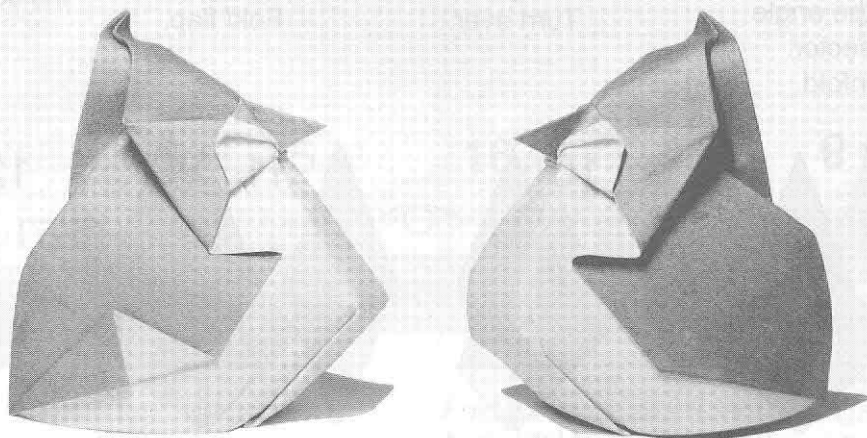
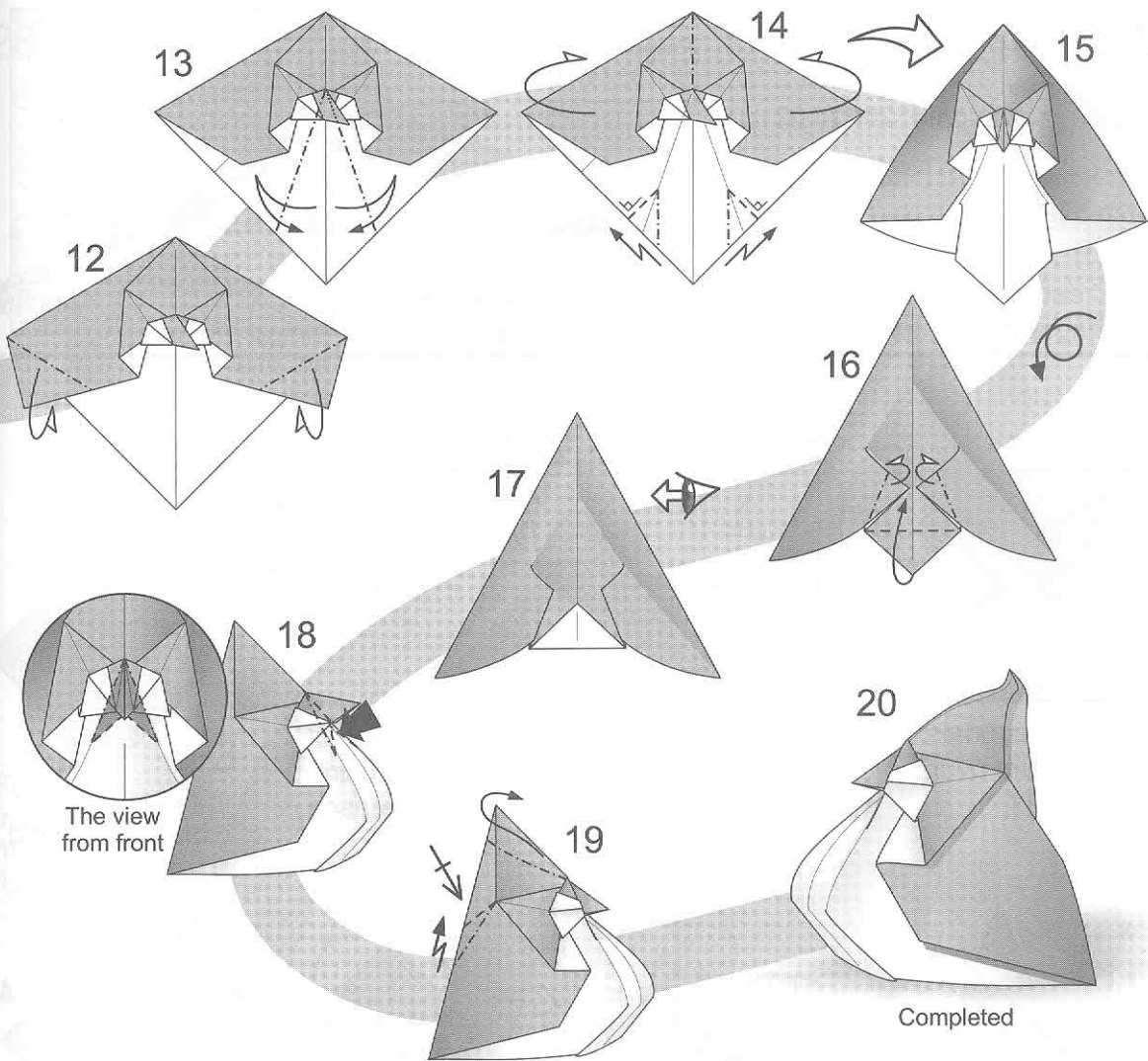

# オオハシ / Toucan

Proportion:  
H: 0.33 / W: 0.63

創作 / Creation date: 2012 / 07

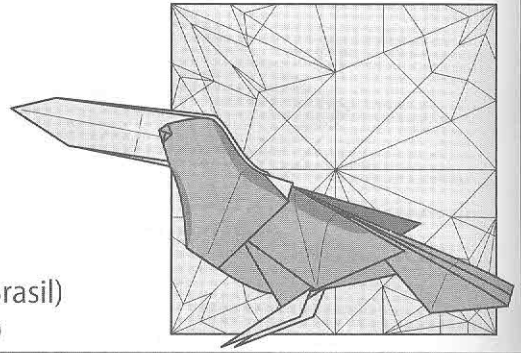
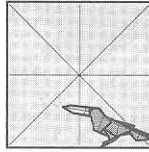

創 / Creator: Nelselon Alves do Prado (Amazonas, Brasil)

図 / Diagrammer: Marcio Noguchi (New York, USA)

1

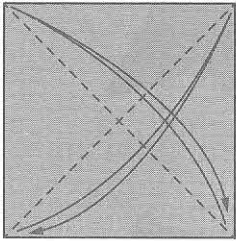

Fold the diagonals.  
Unfold. Turn over.

2

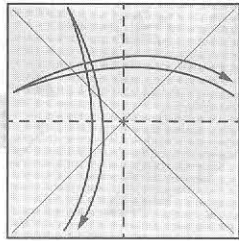

Color side up.  
Fold in half. Unfold.

3

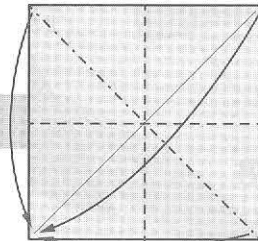

Fold corners as  
indicated, using  
existing creases.  
Rotate.

4

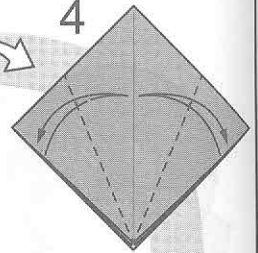

Fold the angle  
bisector. Unfold.

8

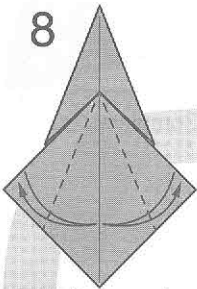

Fold the angle  
bisector.  
Unfold.

7

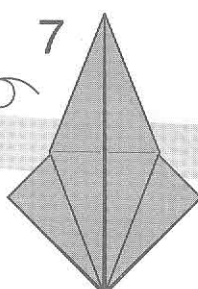

Turn over.

6

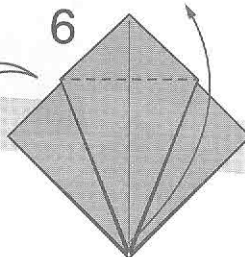

Fold flap.

5

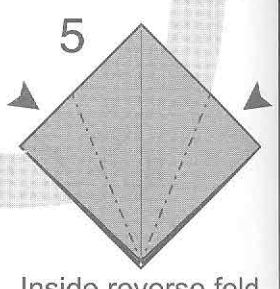

Inside reverse fold.

9

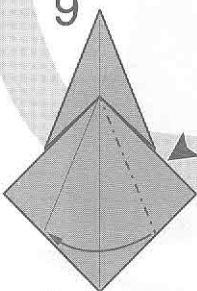

Squash.

10

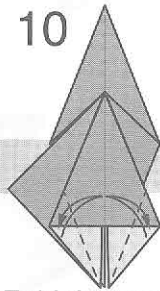

Fold the angle  
bisector. Unfold.

11

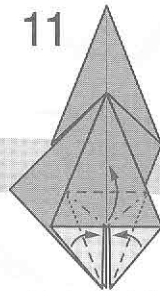

Petal fold.

12

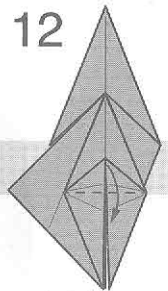

Fold flap.

26 Fold corner to pinch.

27 Fold corner to corner. Unfold.

28 Unfold to step 23.

29 Swivel. Model will not lie flat.

30 Fold flap down, making model flat.

31 Rabbit ear fold. Model will not lie flat.

25 Fold and unfold aligned with the folded edge line.

24 Fold in half, making model flat.

23 Crimp as indicated. Model will not lie flat.

22 Turn over.

21 Fold flap down.

20 Turn over.

19 Fold corner to crease. Unfold.

18 Starting rom cover, fold edge to pinch. Unfold.

17 Fold corner to crease. Unfold.

16 Fold and unfold as far it goes.

15 Turn over.

14 Repeat steps 9 to 13 on the other side.

13 Fold flap.

9-13



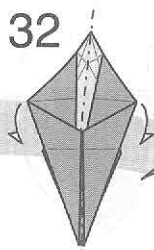

32  
Fold in half,  
making model  
flat.

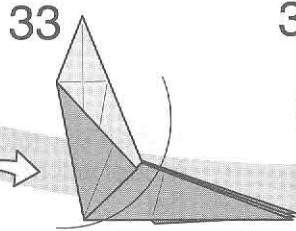

33  
Details of the  
head next.

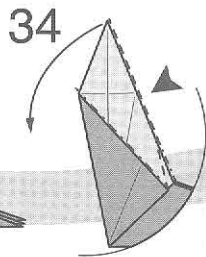

34  
Mountain fold by  
edge and inside  
reverse fold. Note  
the small gusset.

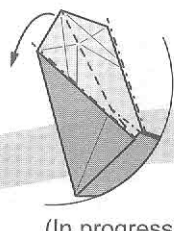

(In progress)

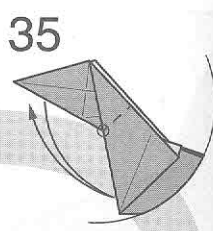

35  
Fold edge to edge  
as indicated.

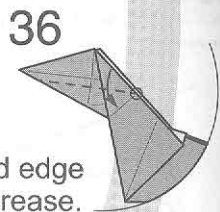

36  
Fold edge to  
crease.  
Model will not lie flat.

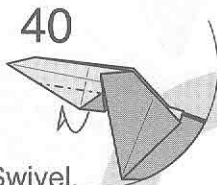

40  
Swivel,  
so that the edges  
become aligned.

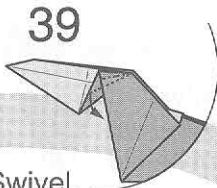

39  
Swivel,  
so that the edges  
become aligned.

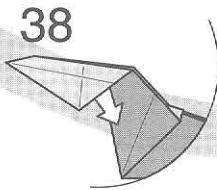

38  
Untrap the paper  
from underneath.

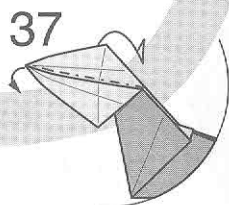

37  
Outside reverse  
fold.

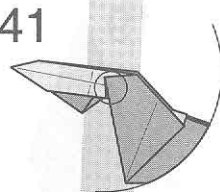

41  
Details of the eye  
next.

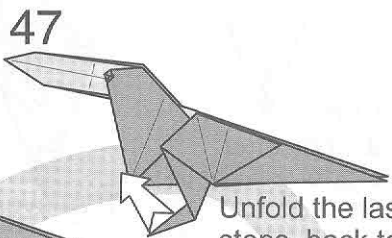

47  
Unfold the last two  
steps, back to step 44.

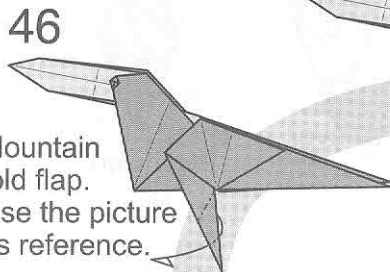

46  
Mountain  
fold flap.  
Use the picture  
as reference.

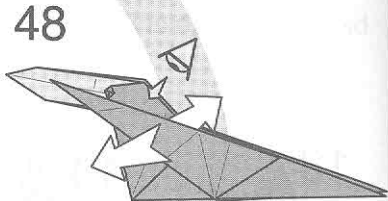

48  
Open the layers of the flap.  
View from inside.

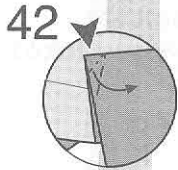

42  
Squash fold.

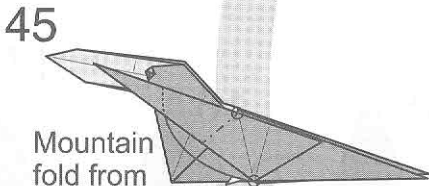

45  
Mountain  
fold from  
the point indicated  
as far it goes.

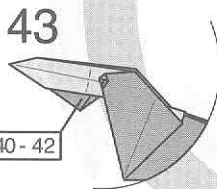

43  
Repeat steps  
40 to 42 on  
the back.

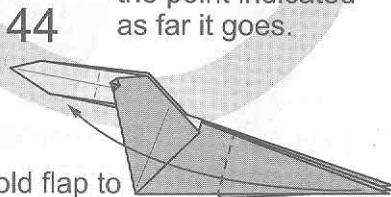

44  
Fold flap to  
the other side.

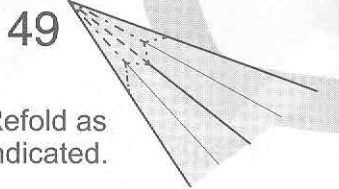

49  
Refold as  
indicated.

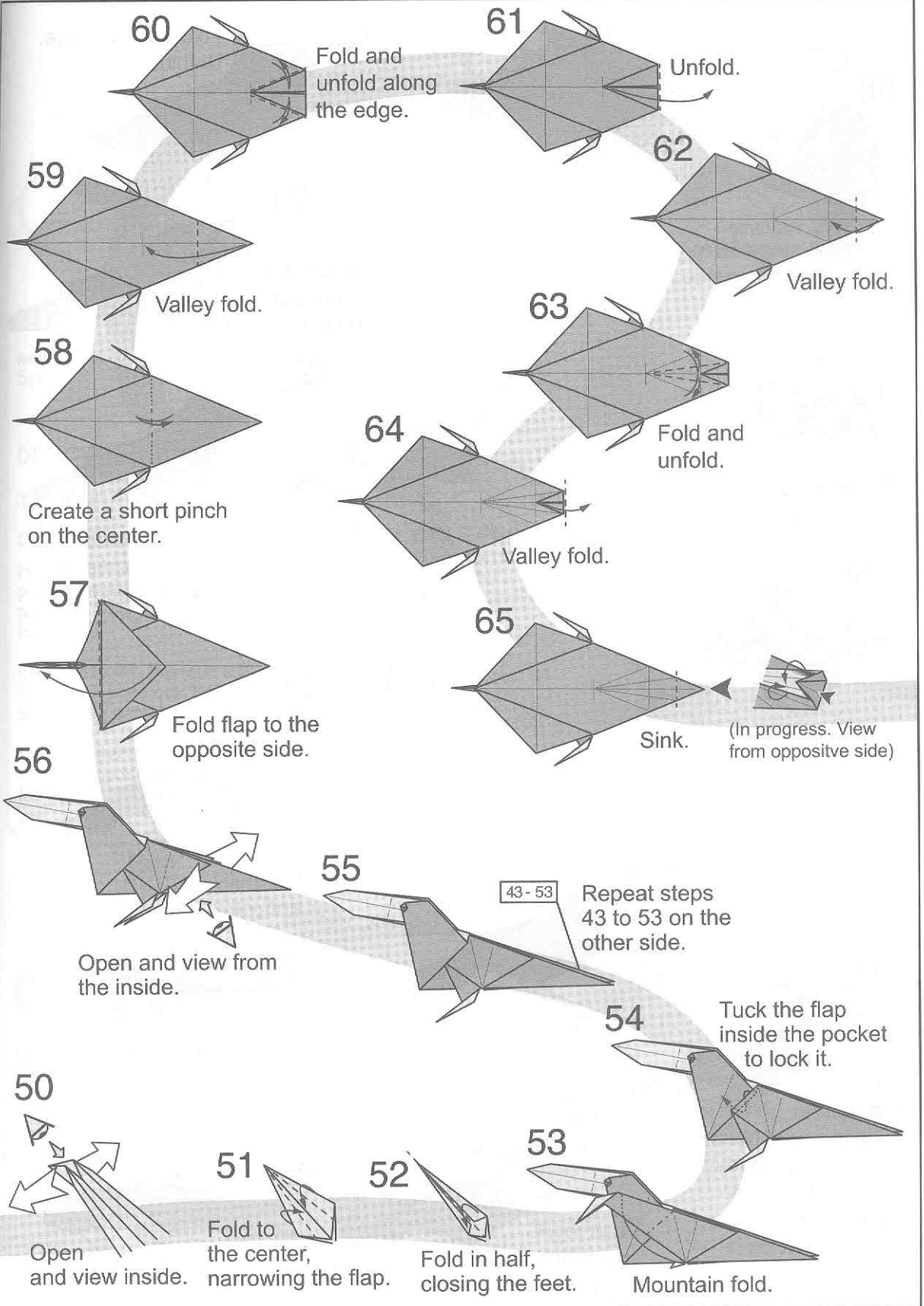

66-67

68

69

70

71

72

73

74

75

76

77

78

Repeat steps 66 to 67 on the other side.

Mountain fold under to create a lock.

Pleat fold. Use existing valley crease. See next step for reference for mountain fold.

Fold in half.

Fold edge to edge. Unfold.

Squash on crease created on previous step.

Tuck flap inside pocket underneath to lock the body.

Push a very small corner inside.

(View from the inside)

Carefully open and view from inside.

Mountain fold corner to edge.

View from the side.

Push to shape and to make neck three dimensional.

Fold very small corner inside to round head. Push to shape body and to make three dimensional.

Toucan complete

# PATO

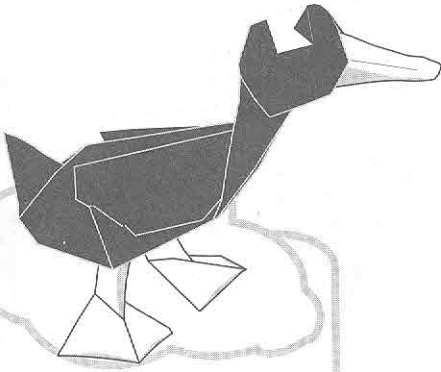

Fernando Gilgado (2012)

[www.flickr.com/photos/gilgado/Spain](http://www.flickr.com/photos/gilgado/Spain)

DIFICULTAD:

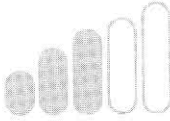

TAMAÑO:  35 cm = 15 cm

COMENTARIO:

Hay que fijarse bien en el pliegue hundido abierto de los pasos 34 y 35 donde se forman las patas.

En el paso 44, hay que estirar las capas para que haya papel suficiente para hacer los ojos.

Una vez terminado, hay que buscar la posición correcta de las patas para que se tenga de pie.

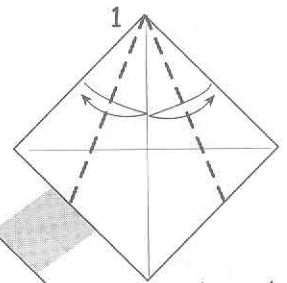

Comenzar después de haber doblado las dos diagonales

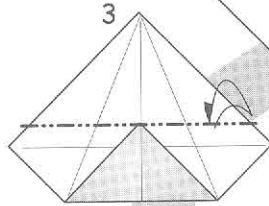
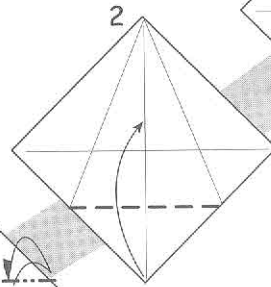

Doblar y desdoblar

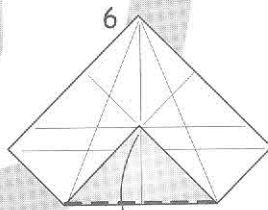
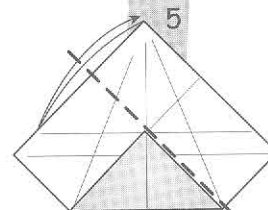
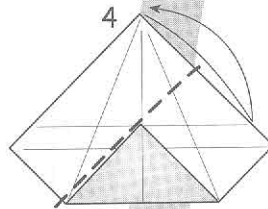

Desdoblar

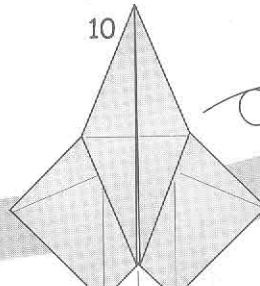
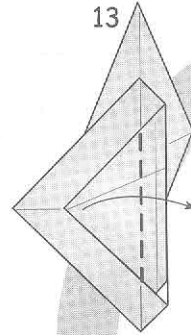
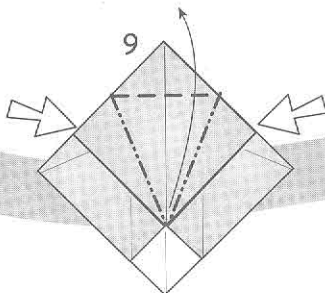
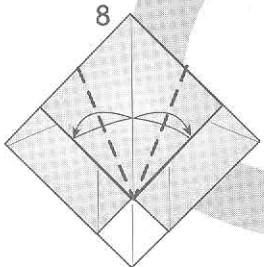
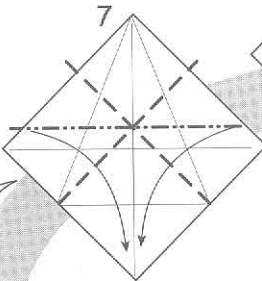

Dar la vuelta

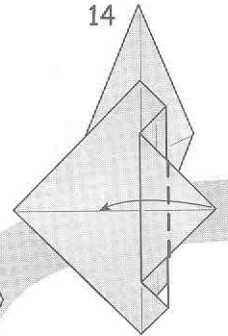

13

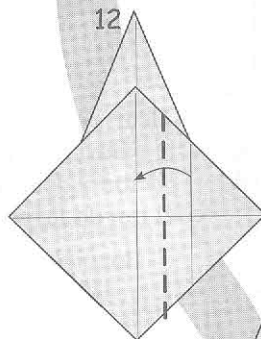

12

Tomar como referencia el vértice formado por las dos solapas

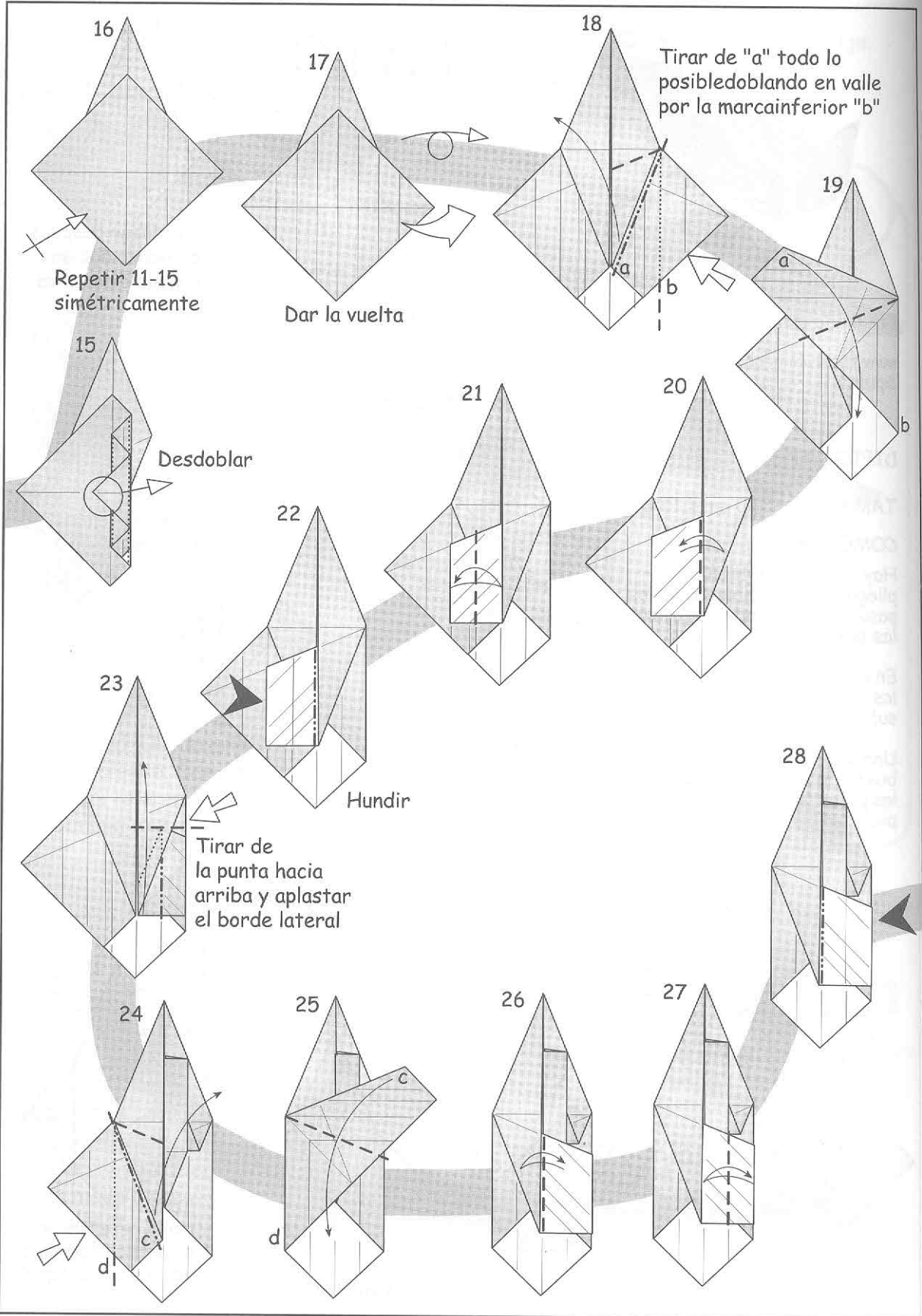

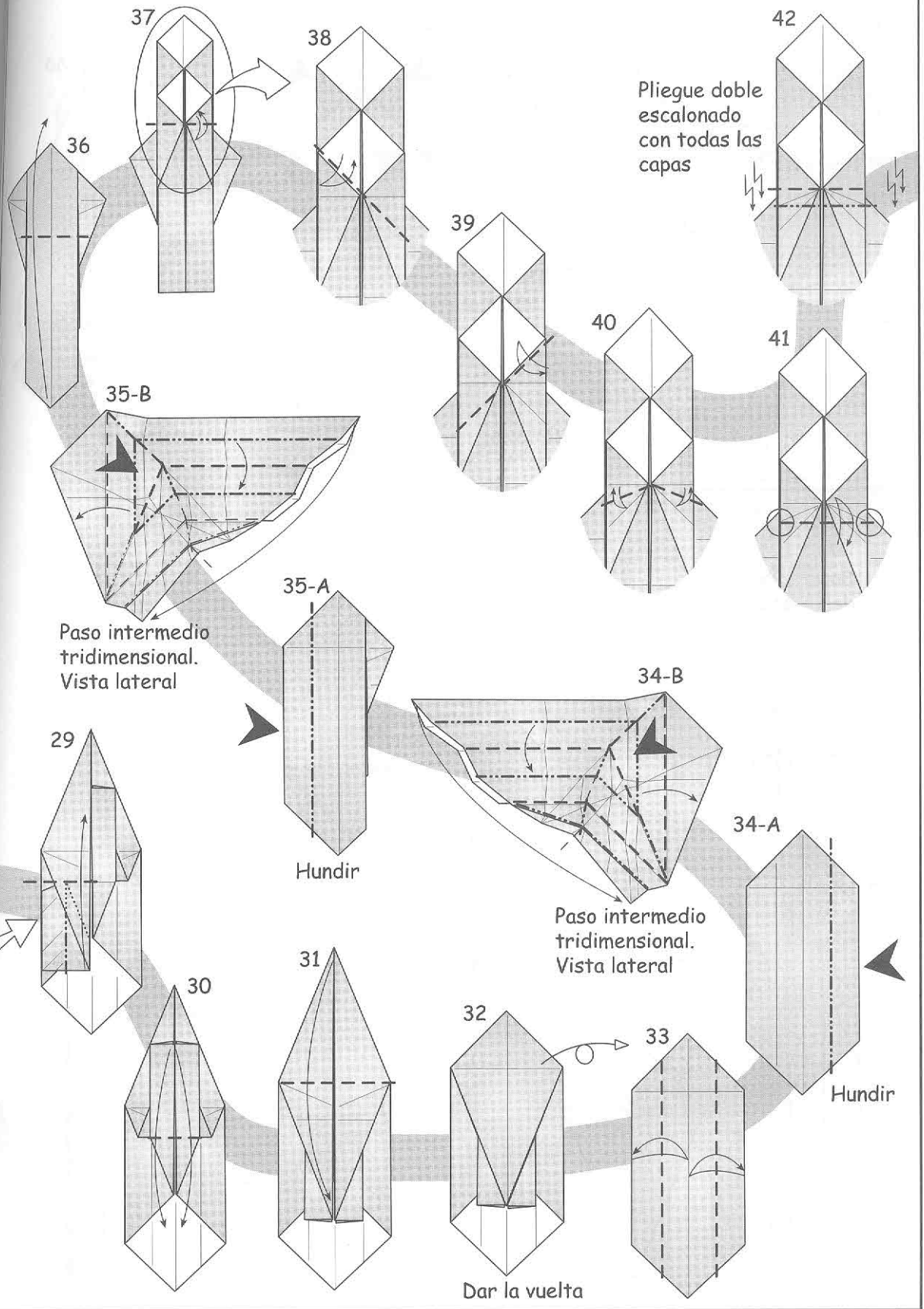

Pliegue doble escalonado con todas las capas

Paso intermedio tridimensional. Vista lateral

Hundir

Paso intermedio tridimensional. Vista lateral

Hundir

Dar la vuelta

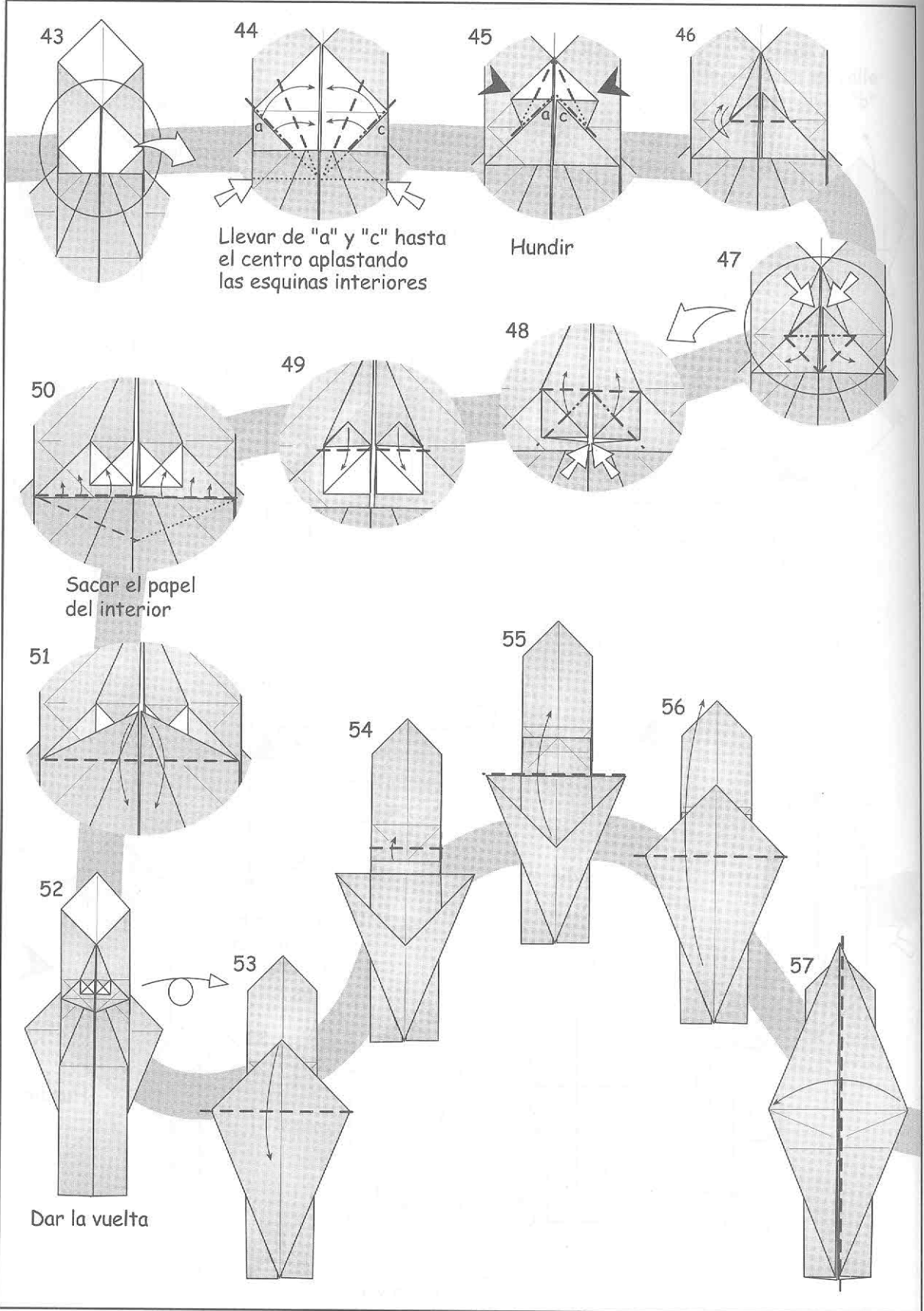

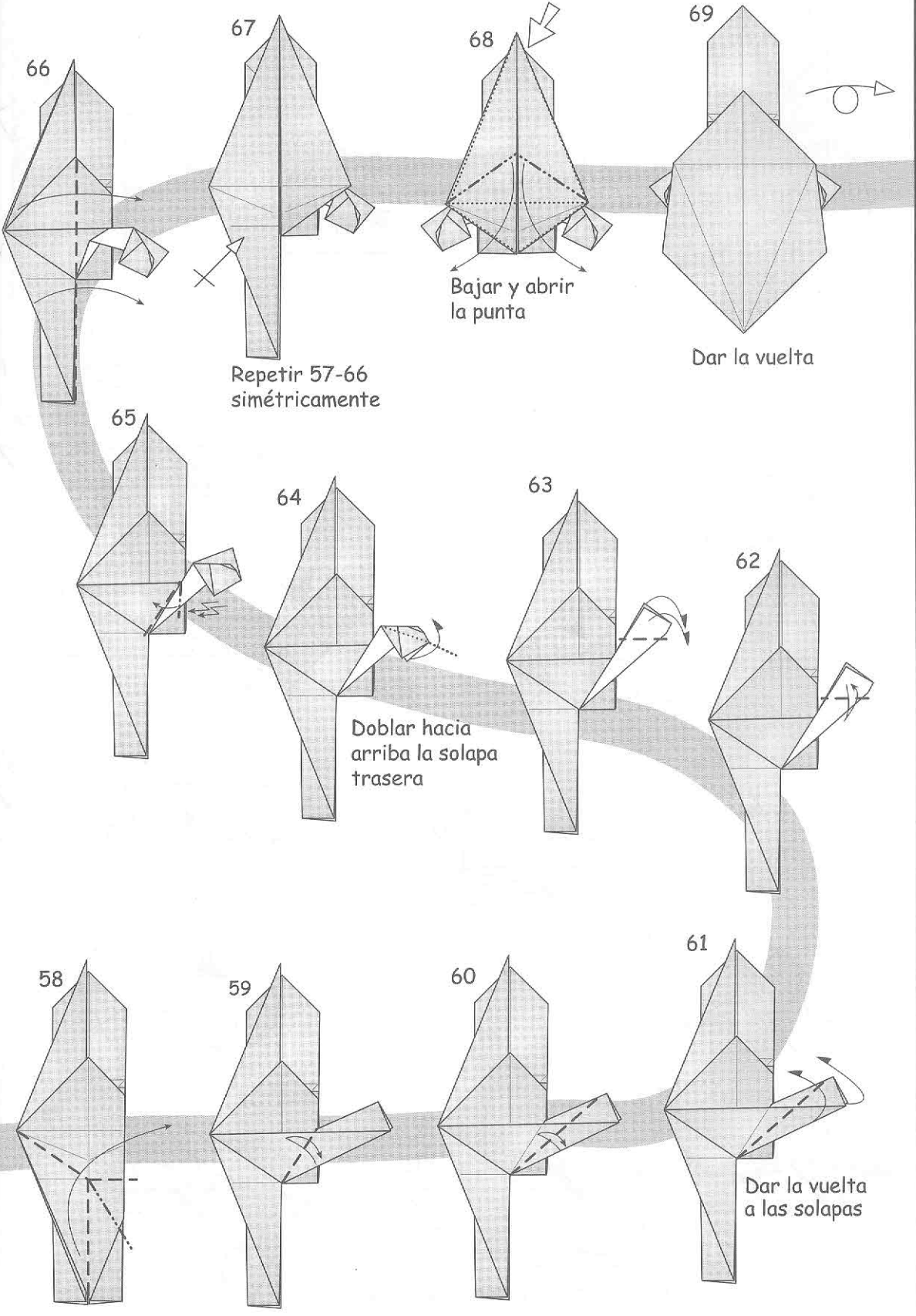



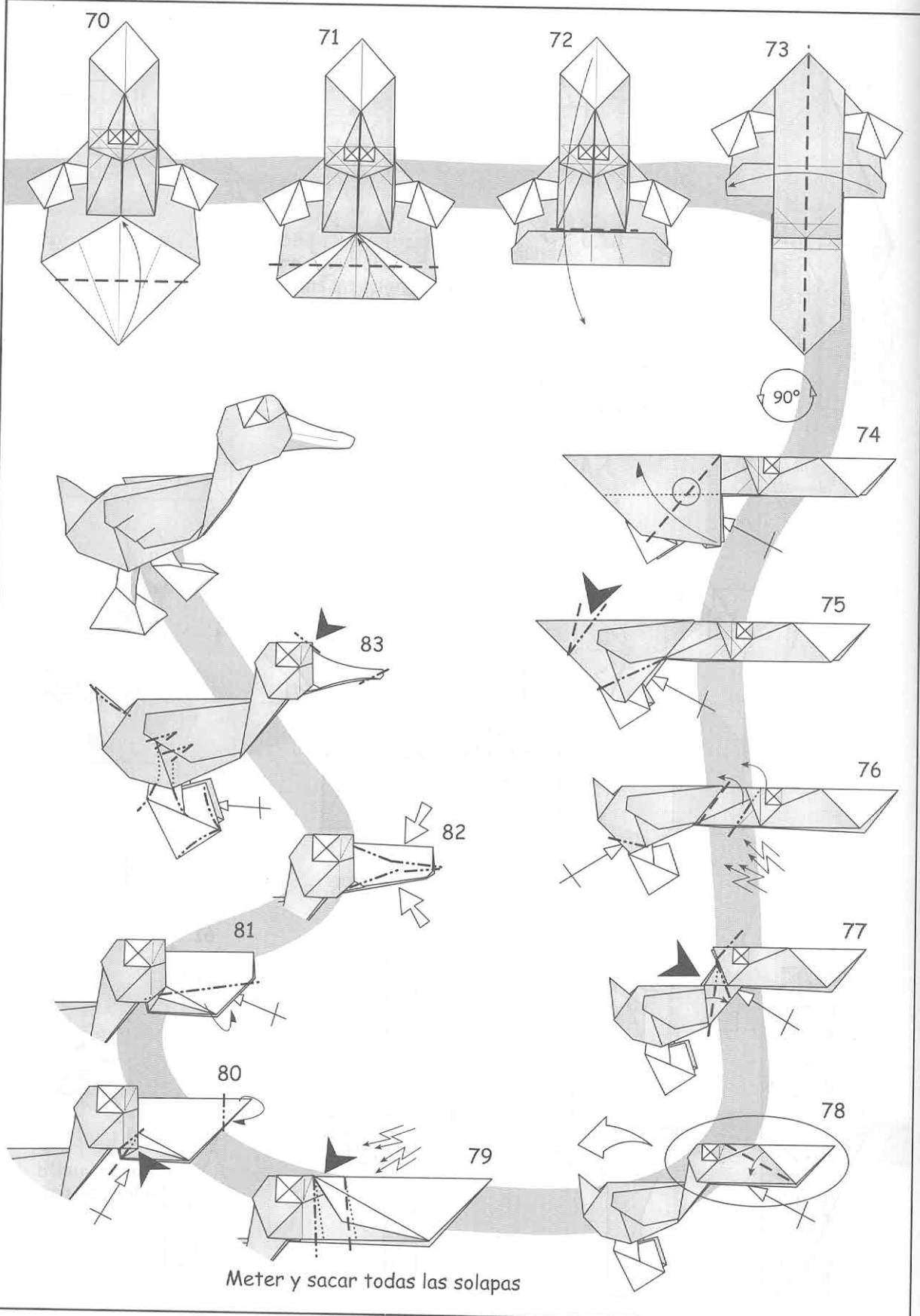

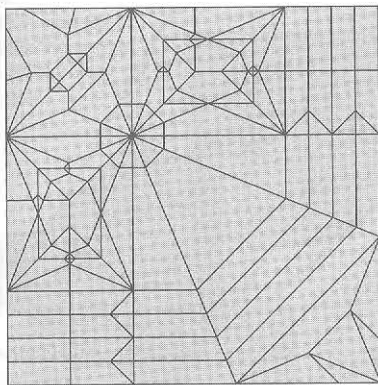

# Woolly Mammoth

William Hartman

A 10 inch square of foil is suitable for practice, but the model is best folded with a large square of hefty paper that is brown on one side and white on the other. Wet finishing the model leads to the best results.

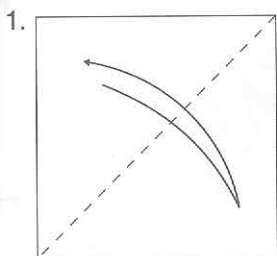
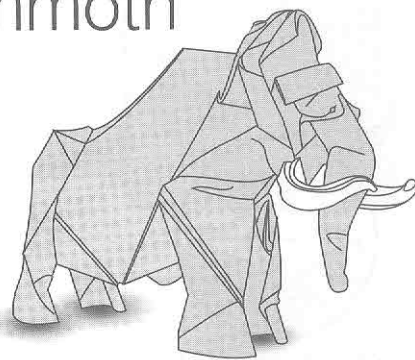

1. With the white side up, valley fold half diagonally. Flip over.

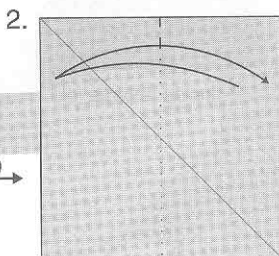

2. Pinch at 1/2 on the top edge.

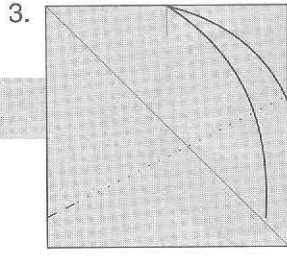

3. Align the bottom right corner with the pinch from step 2. Pinch on the left edge.

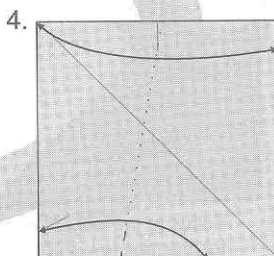

4. Align the top left corner with the right edge. Align the pinch from step 3 with the bottom edge. Pinch at the bottom. Be as accurate as possible.

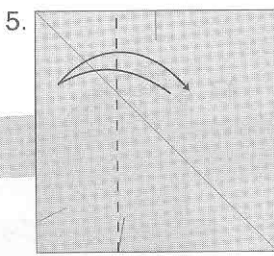

5. Crease vertically at the pinch from step 4.

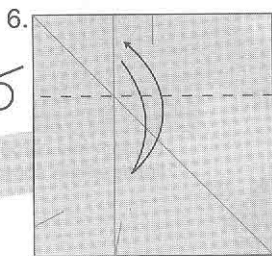

6. Valley fold horizontally at the intersection. Flip over.

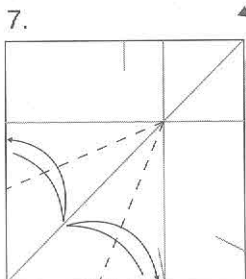

7. Bisect with valley folds. Flip over.

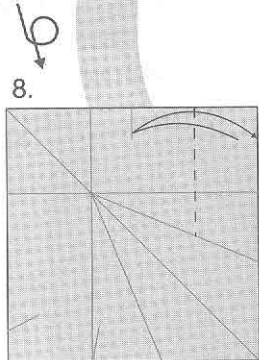

8. Valley fold the right edge to the 1/2 mark.

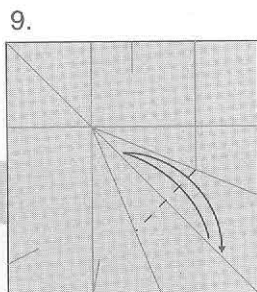

9. Fold and unfold.

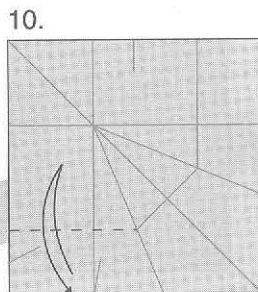

10. Fold and unfold.

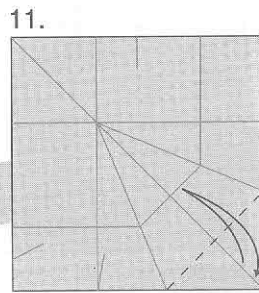

11. Valley fold, using the endpoints of the creases made in step 7 for reference.

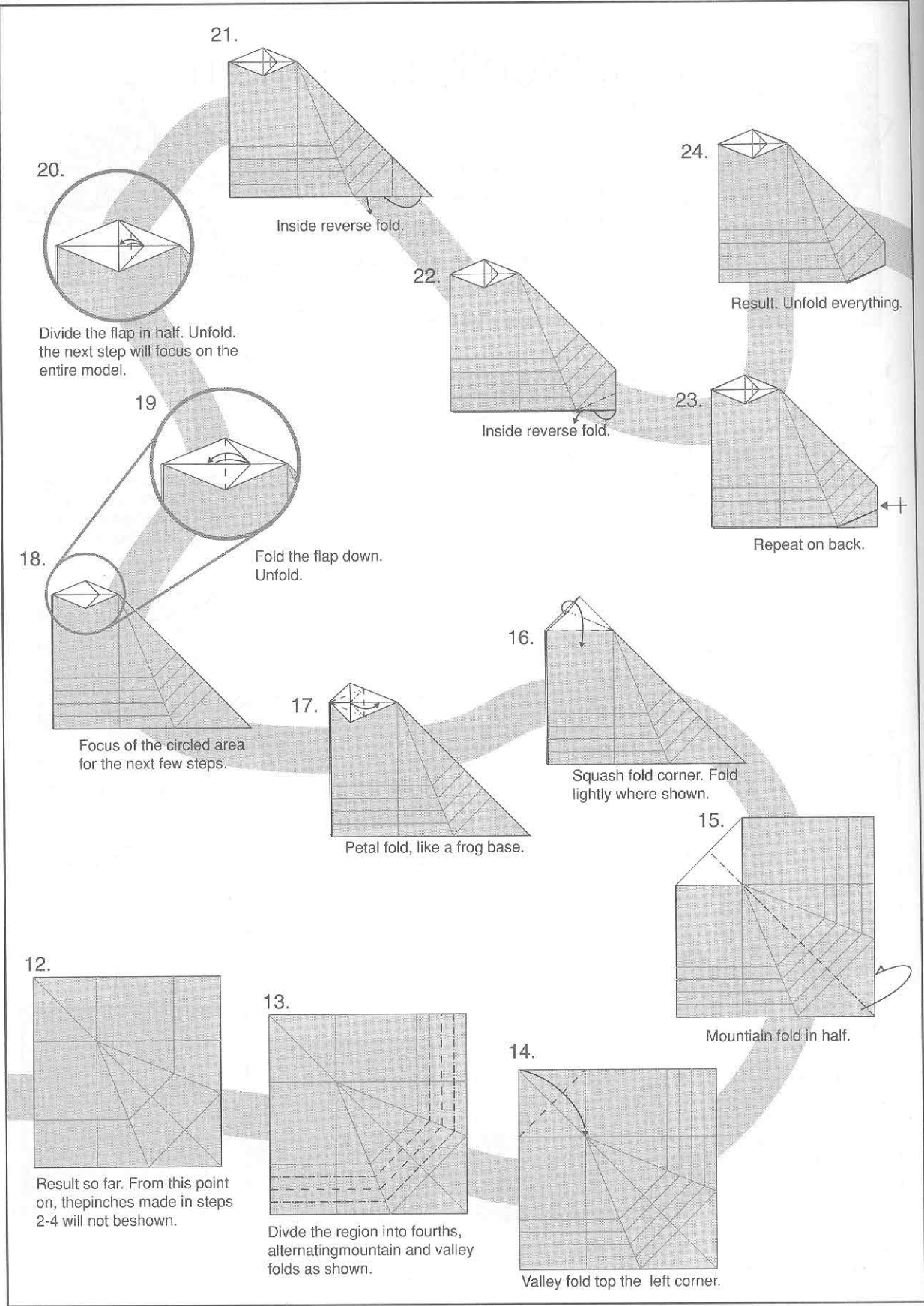

21.

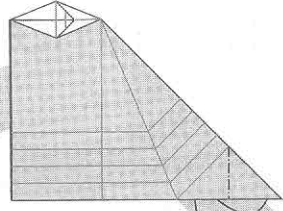

Inside reverse fold.

24.

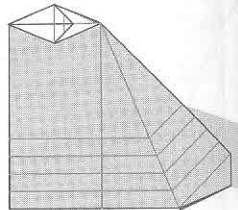

Result. Unfold everything.

20.

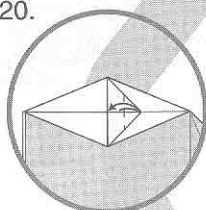

Divide the flap in half. Unfold. the next step will focus on the entire model.

22.

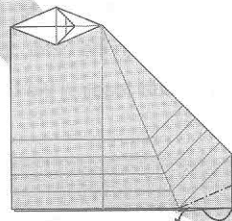

Inside reverse fold.

23.

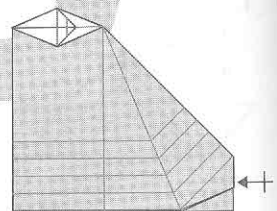

Repeat on back.

19.

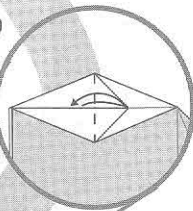

Fold the flap down. Unfold.

18.

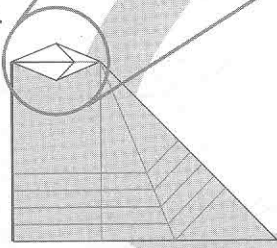

Focus of the circled area for the next few steps.

17.

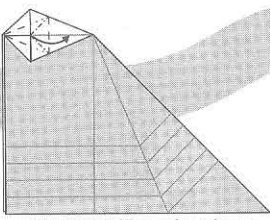

Petal fold, like a frog base.

16.

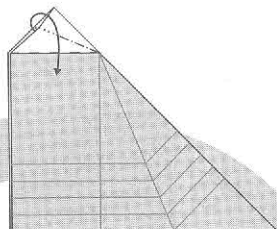

Squash fold corner. Fold lightly where shown.

15.

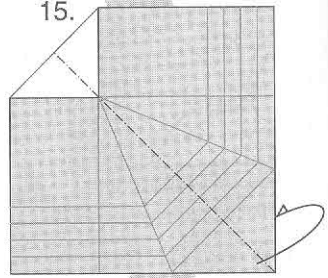

Mountain fold in half.

12.

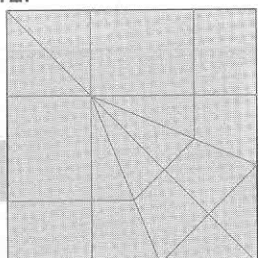

Result so far. From this point on, the pinches made in steps 2-4 will not be shown.

13.

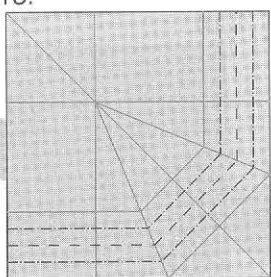

Divide the region into fourths, alternating mountain and valley folds as shown.

14.

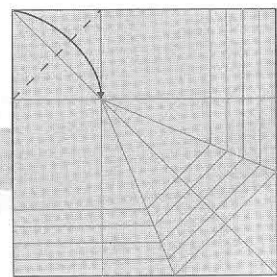

Valley fold top left corner.

26. Extend the creases made in step 20 towards the corner with valley folds. Flip over.

27. Fold and unfold. After this step, focus on the entire square. Flip over.

28. Fold and unfold.

29. Fold and unfold.

30. Collapse like a preliminary base.

31. Valley fold sharply.

32. Valley fold along angle bisectors, but only on the white area.

33. Result. Only the section that was collapsed in step 30 should be creased sharply.

34. Valley fold the corner.

35. Precrease as shown.

36. Collapse base as a stretched bird base.

37. Mountain fold in half along the diagonal.

38. Inside reverse fold.

25. Focus on top left corner.

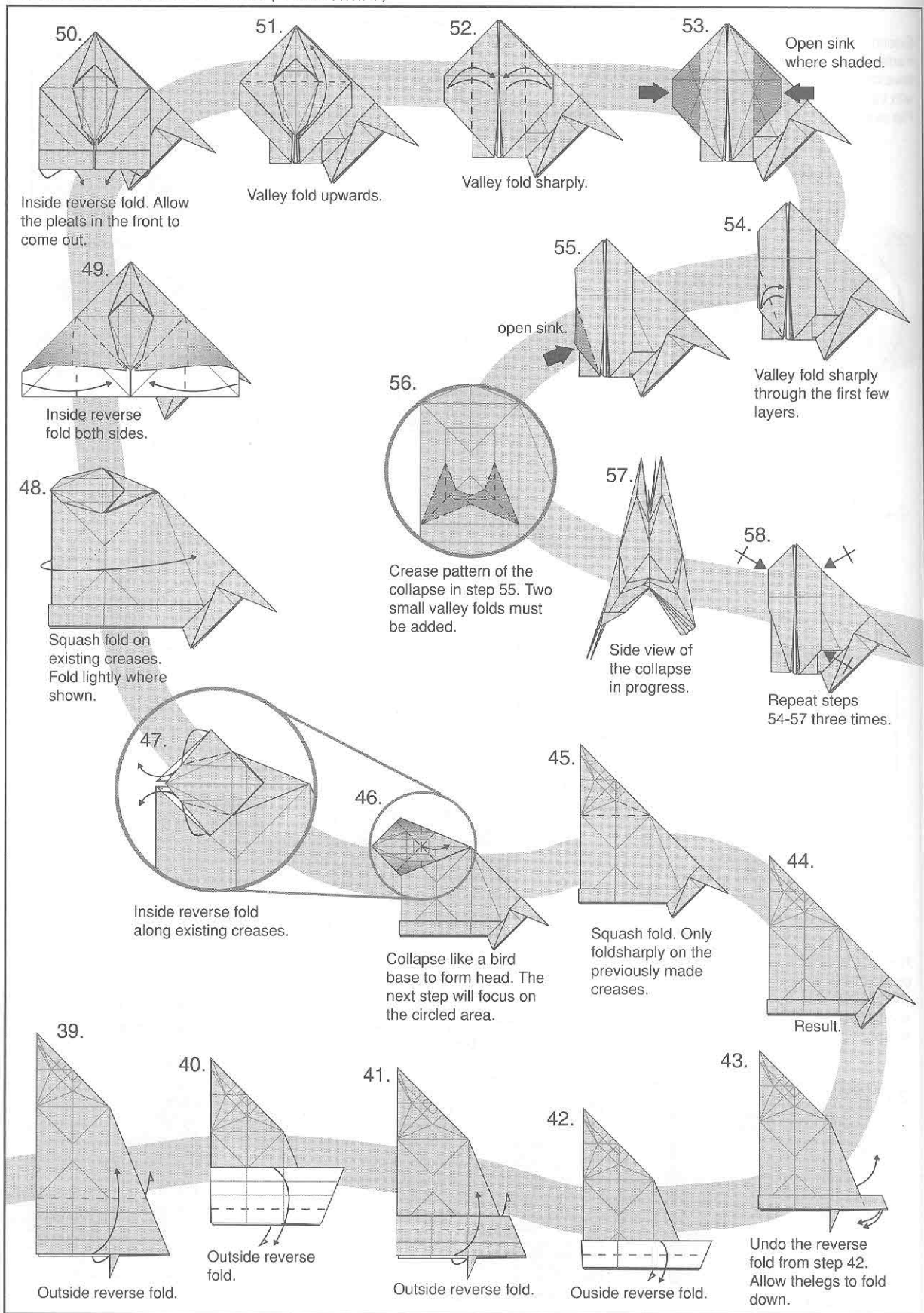

71. Valley fold several layers, back to the layers visible in step 65.

72. Valley fold.

73. Repeat steps 62-72 on left.

74. Open sink.

75. Focus on the circled area.

76. Inside reverse fold the inner flaps downwards.

77. Rabbit ear fold to form eyes.

78. Squash fold.

79. Bring the shaded area to the rear.

80. Rabbit ear fold to form brow.

81. Valley fold.

82. Valley fold.

83. Valley fold.

84. Result. Focus on the entire model again.

59. Valley fold through several layers.

60. Crease sharply.

61. Open sink along the crease from step 60.

62. Fold and unfold along an existing crease.

63. Open sink along the crease from step 62.

64. Valley fold lightly.

65. Bisect with a valley fold.

66. Valley fold.

67. Open sink along angle bisector.

68. Valley fold.

69. Valley fold over. Squash fold the captured layers.

70. Step 69 in process.

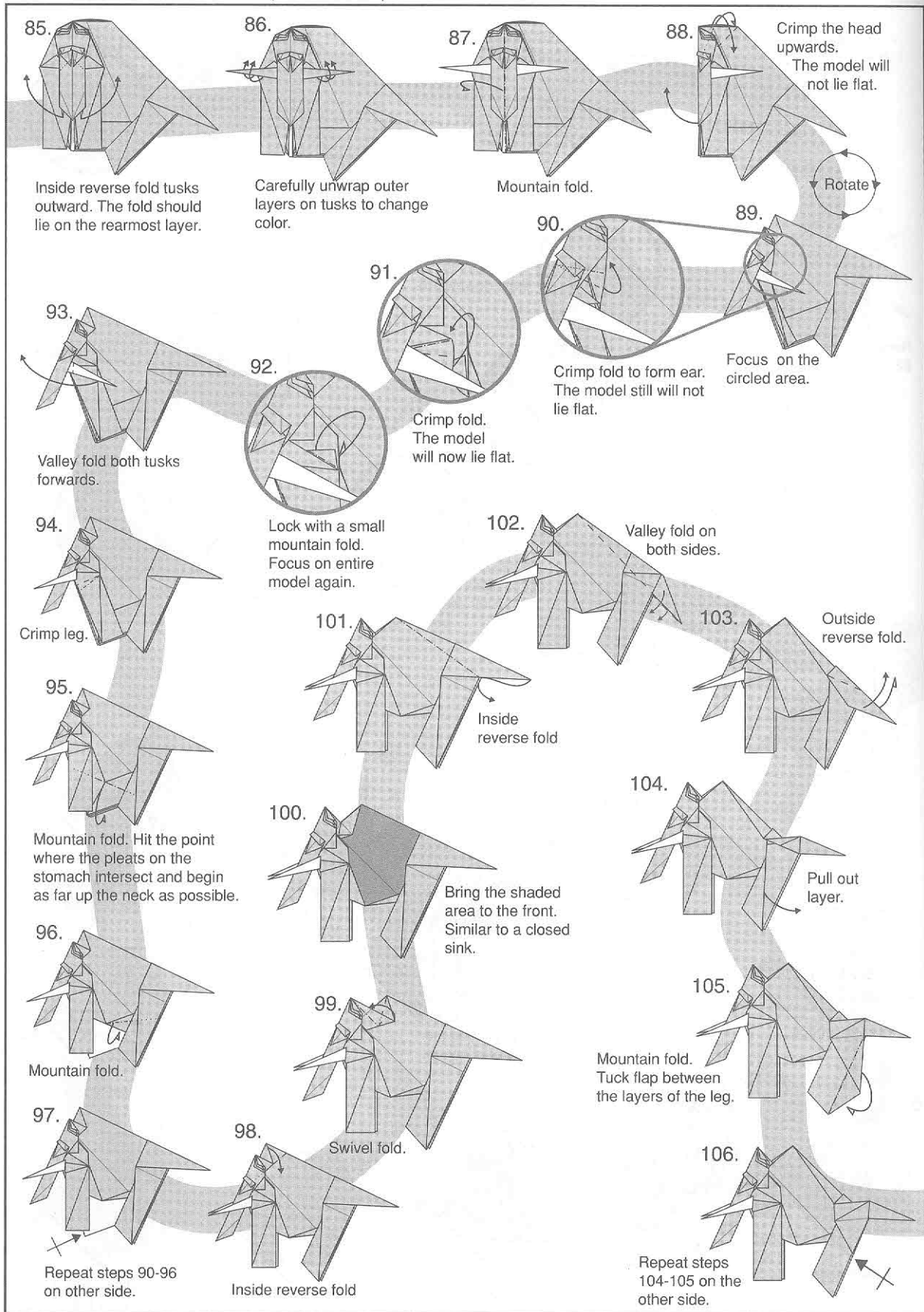

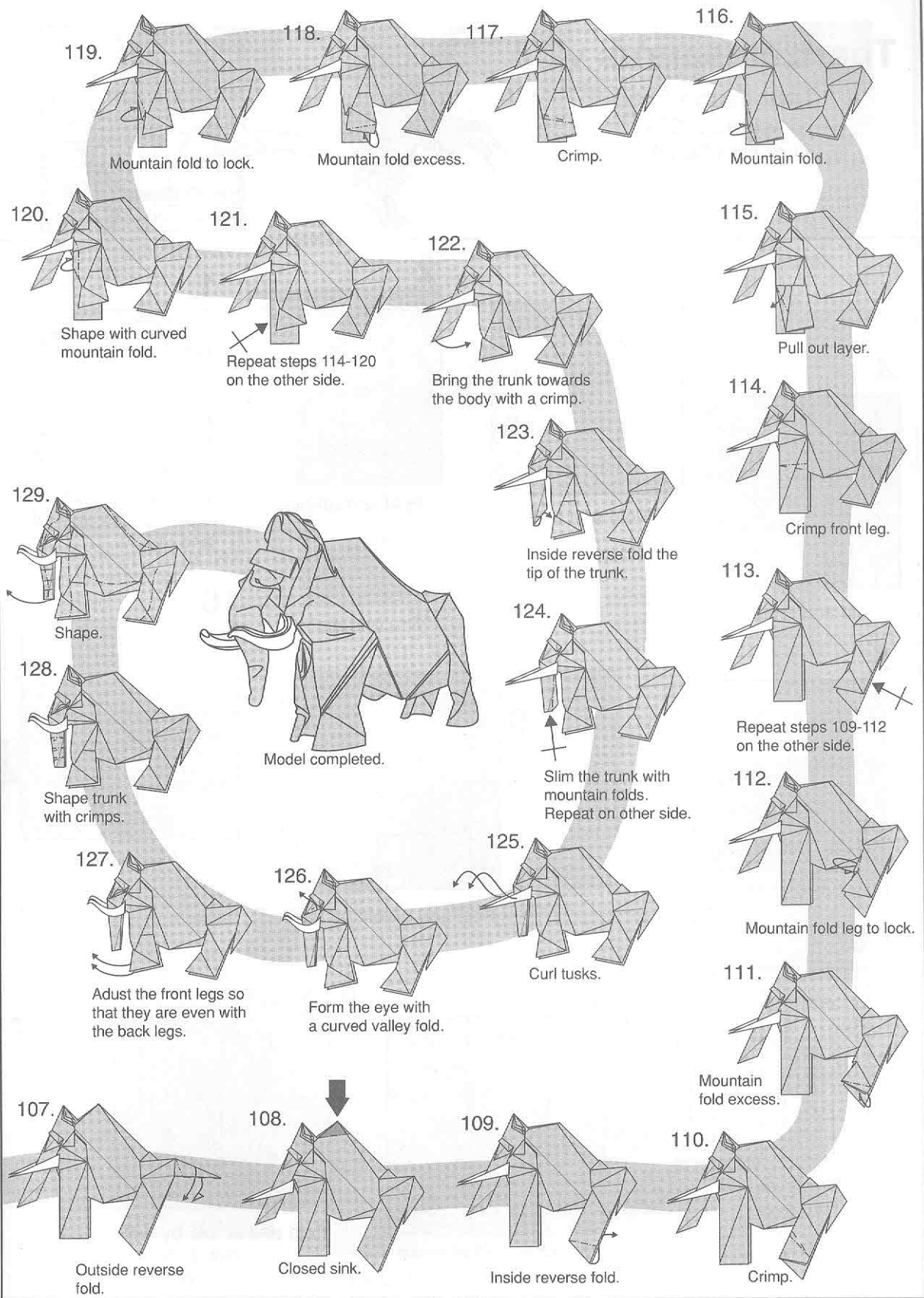



# Therizinosaurus v2.0

Tran Trung Hieu  
Designed: 2011  
Diagram 06/2013

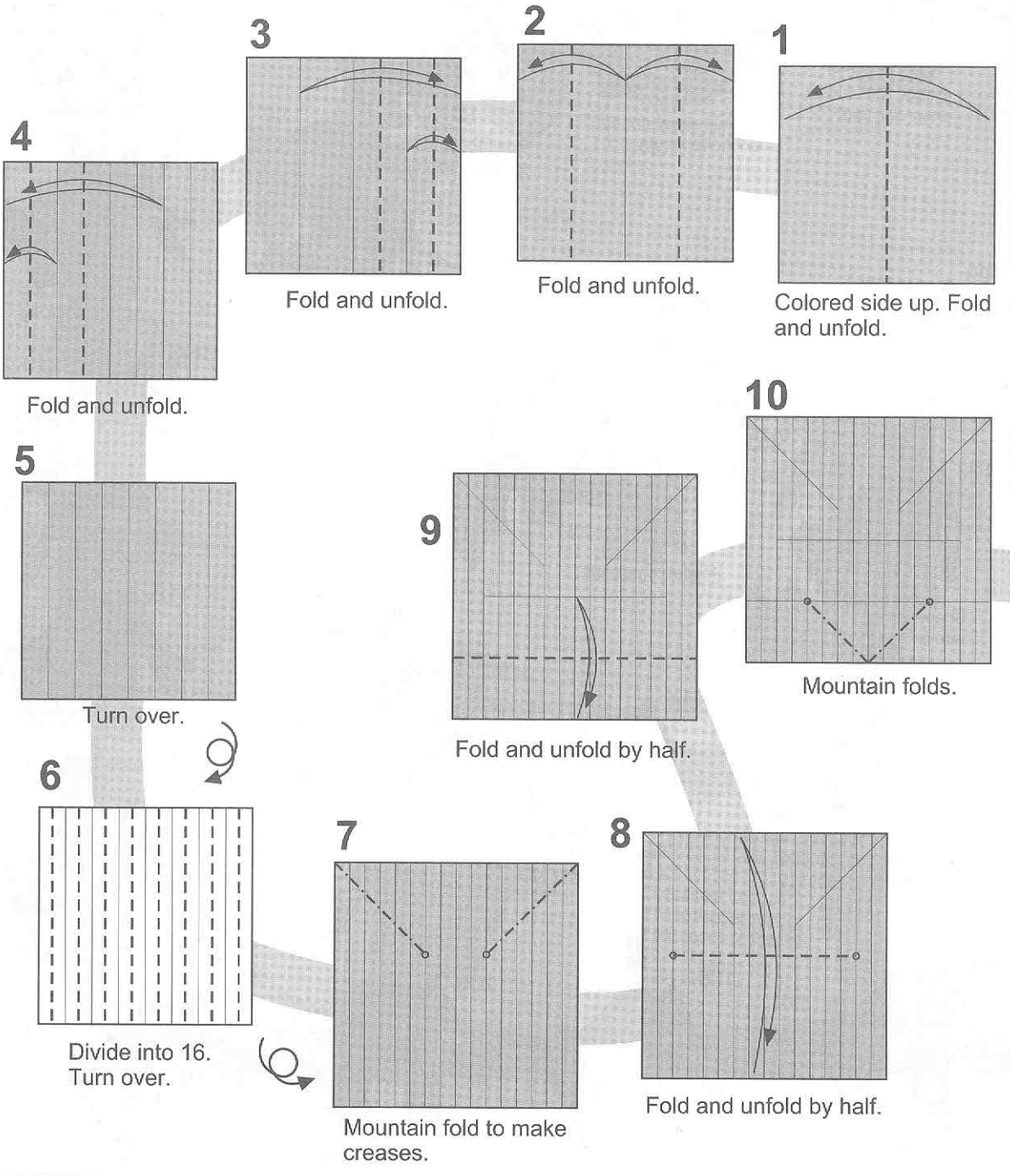
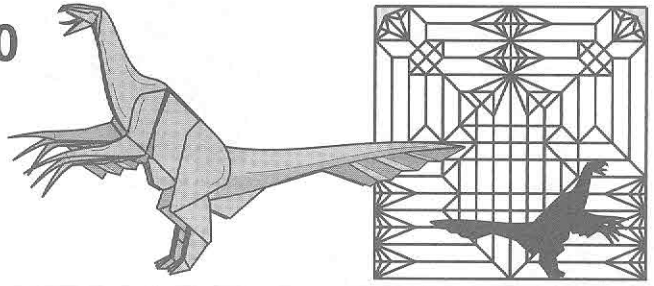

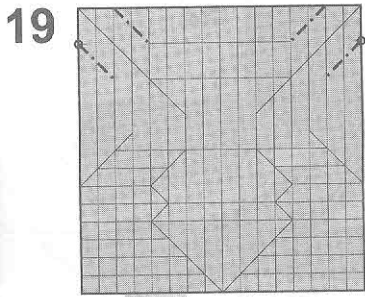

19 Make diagonal creases.

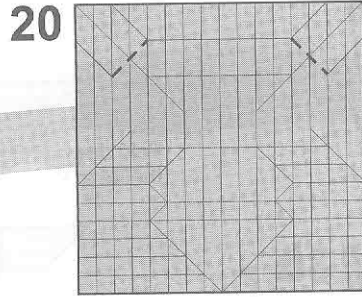

20 Make diagonal creases.

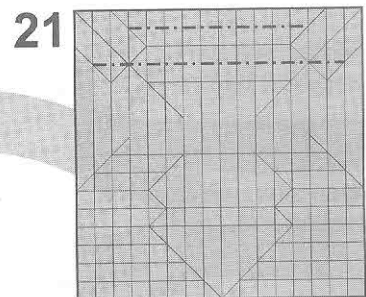

21 Make creases.

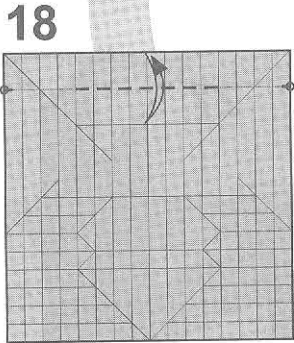

18 Fold and unfold by half only 8 central grids and 2 edges.

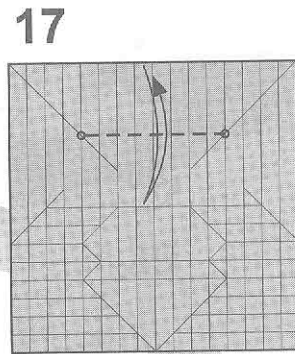

17 Fold and unfold by half.

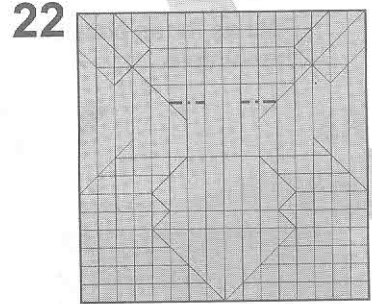

22 Make creases.

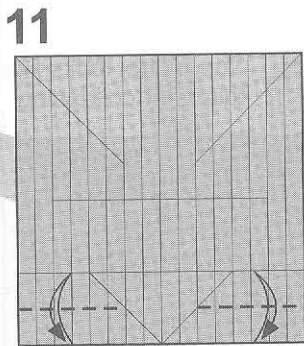

11 Fold and unfold by half.

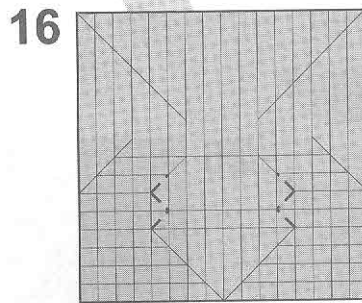

16 Make creases.

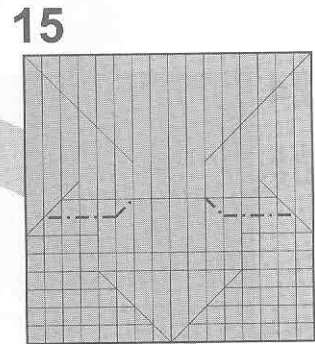

15 Make creases.

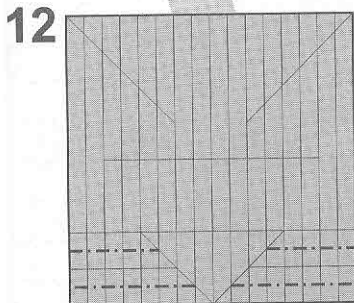

12 Make creases with mountain fold.

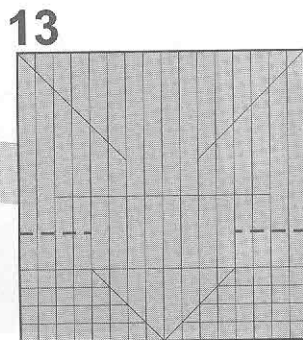

13 Valley folds by half.

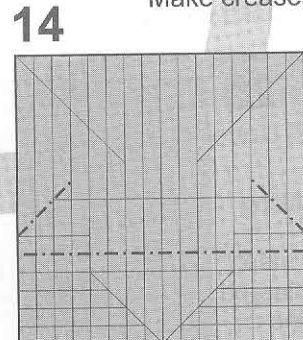

14 Mountain folds.

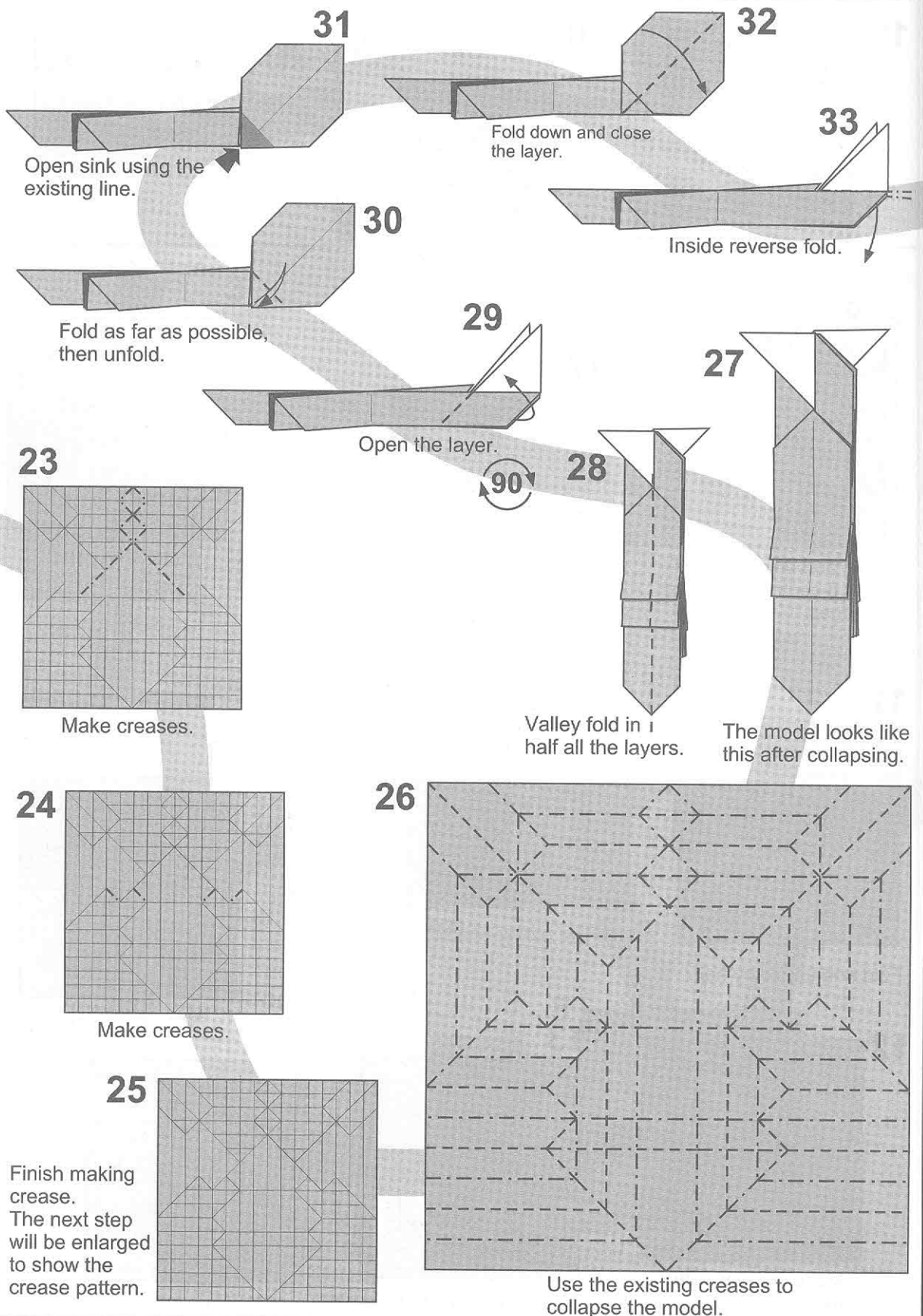

34

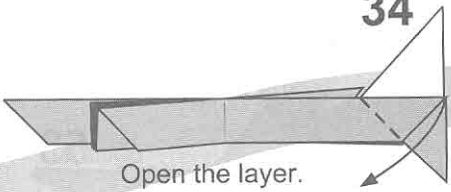

Open the layer.

35

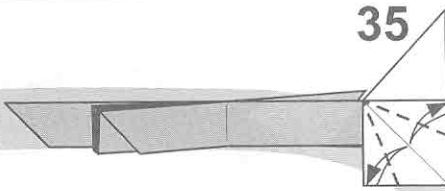

Fold and unfold by half 2 angles.

36

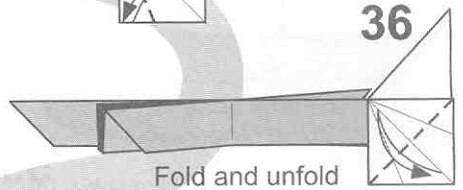

Fold and unfold diagonal.

37

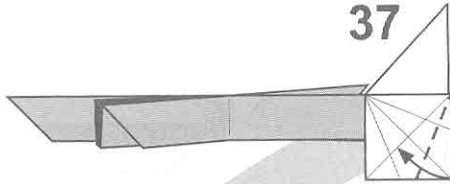

Valley fold to the central line.

38

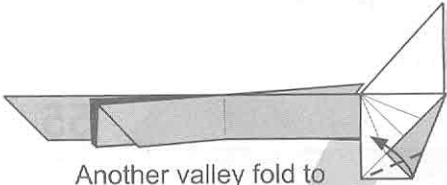

Another valley fold to the central line.

48

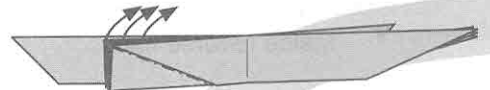

Inside reverse fold 3 layers.

39

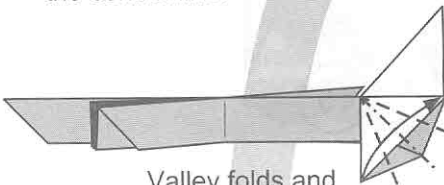

Valley folds and mountain fold to close the layer.

47

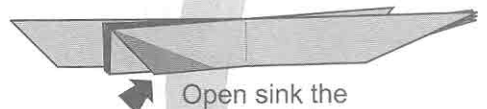

Open sink the darkened area.

40



Make crease by half of the angle.

46

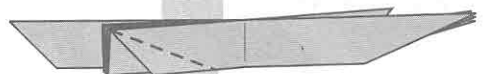

Valley fold to make crease.

41

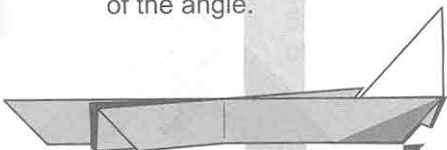

Open sink using existing crease.

29-44

45

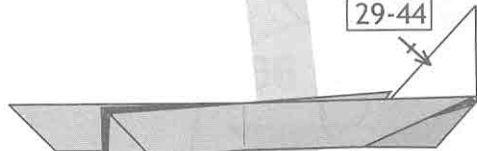

Repeat step 29 - 44 to the other layer.

42

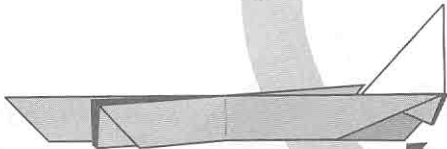

Open sink the other side of the foreleg.

44

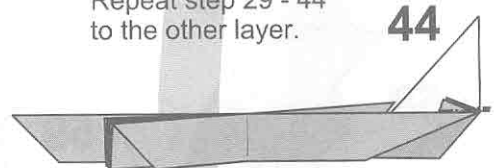

Inside reverse fold 2 layers.

43

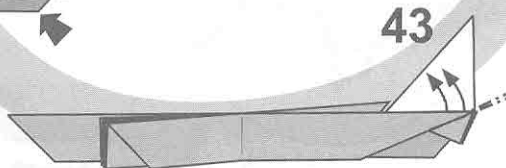

Inside reverse fold 2 layers.

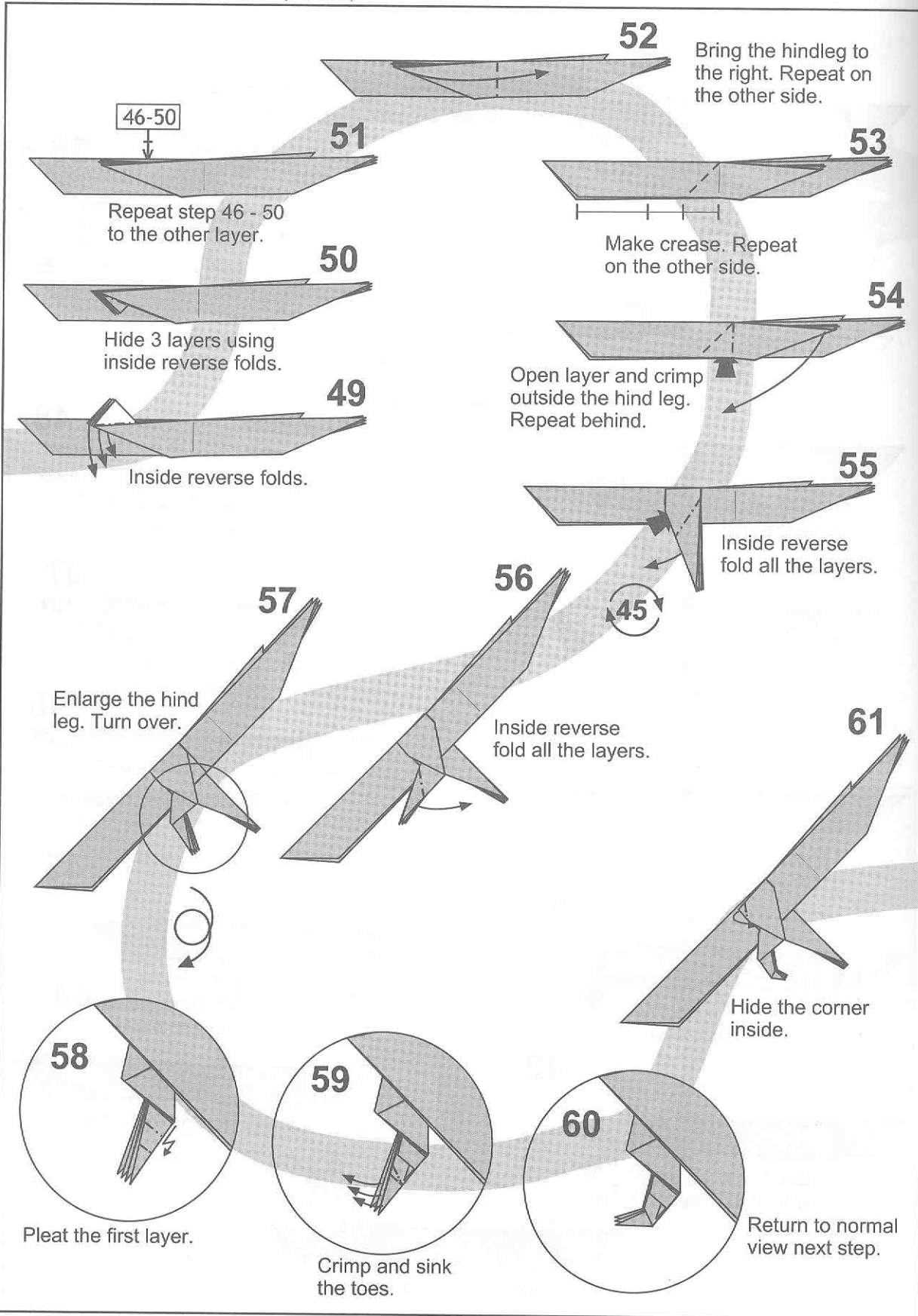

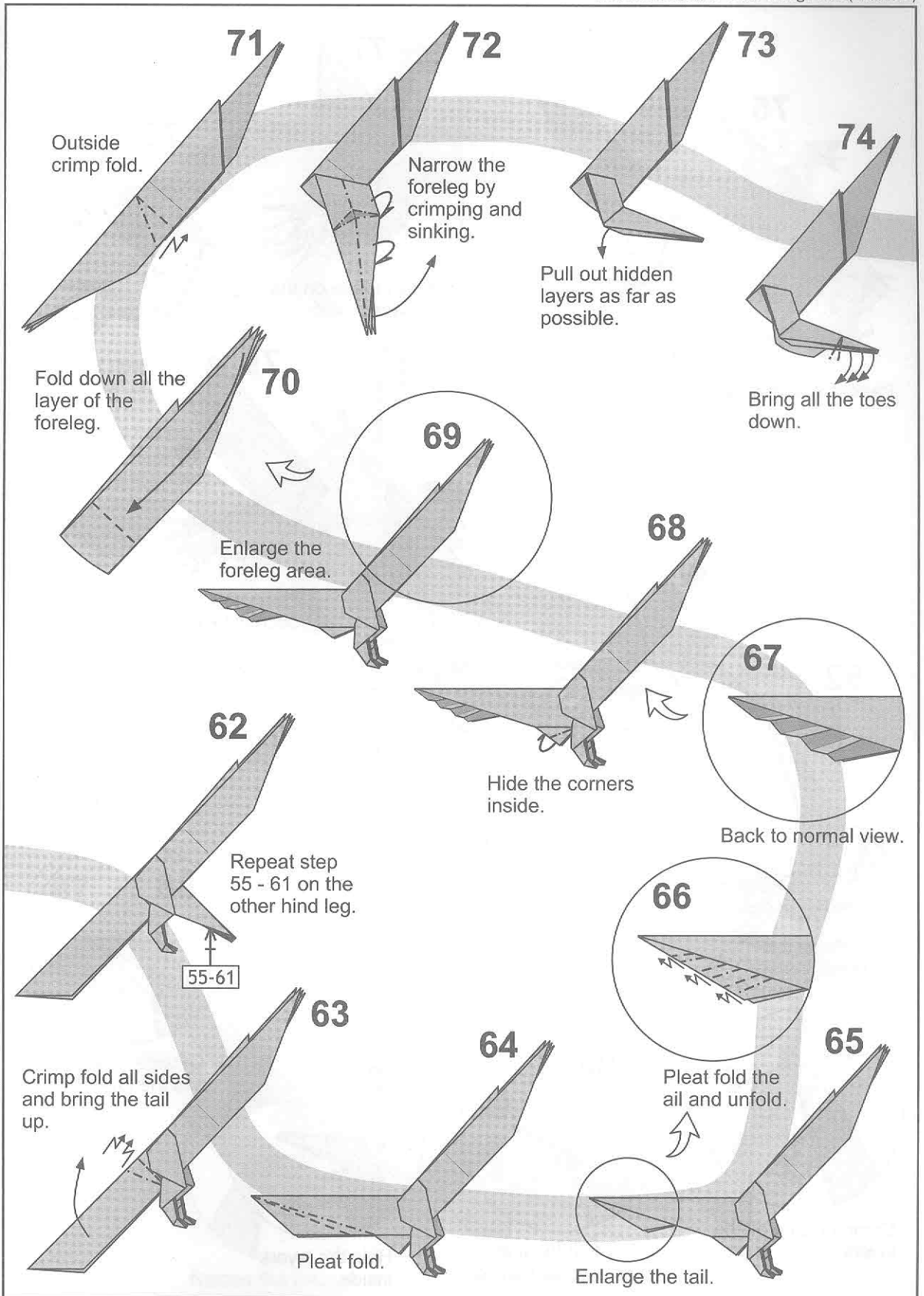

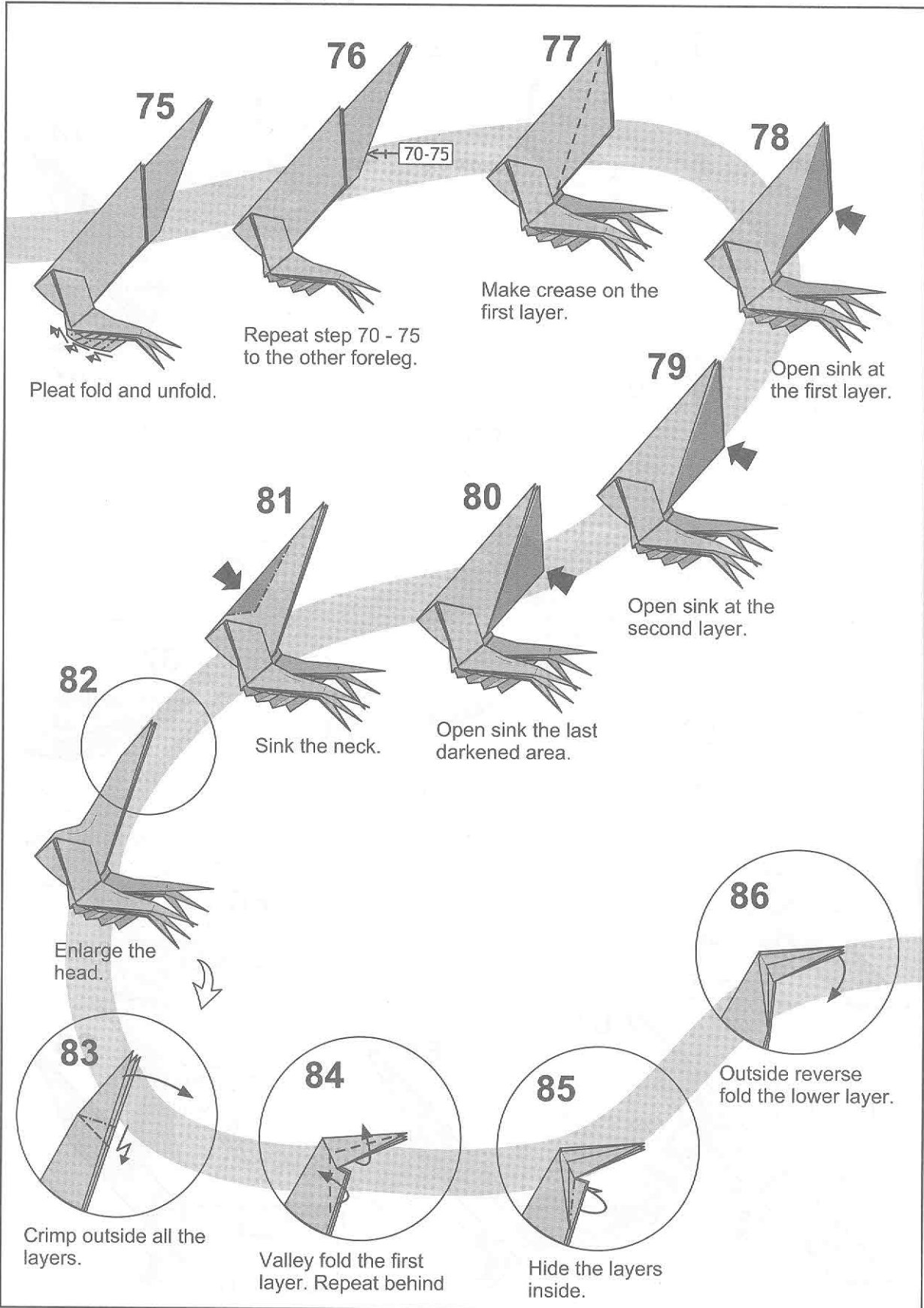

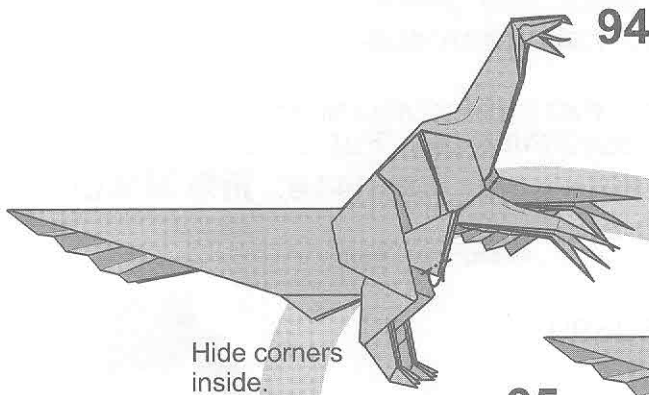

Hide corners inside.

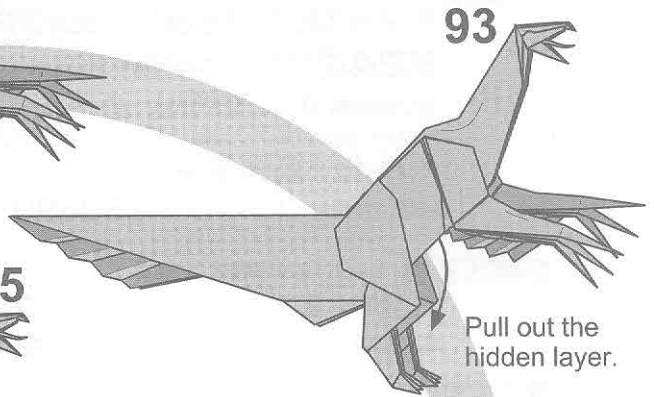

Pull out the hidden layer.

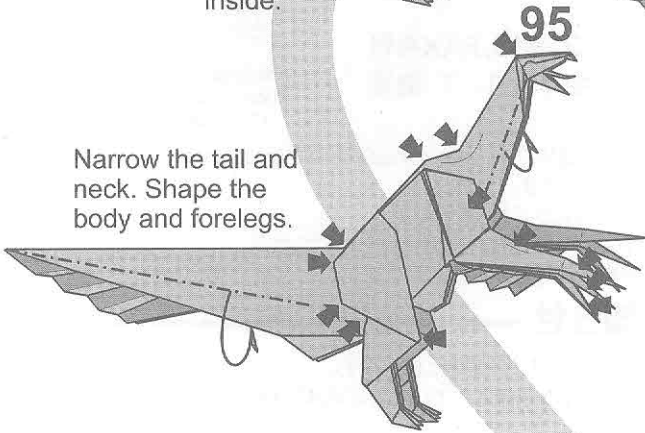

Narrow the tail and neck. Shape the body and forelegs.

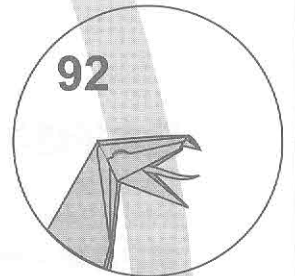

92

Finish folding, back to normal view.

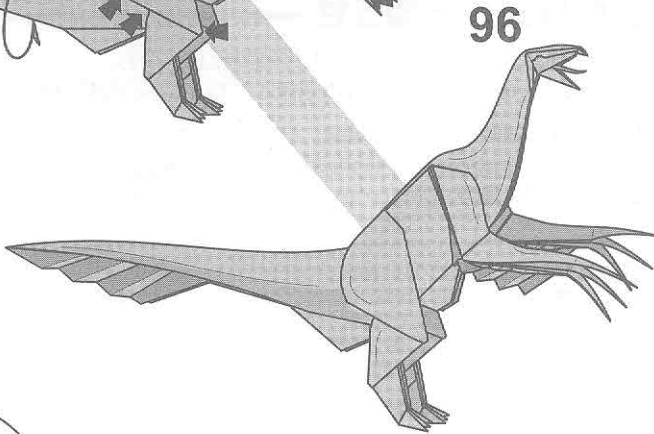

96

Therizinosaurus v2.0.

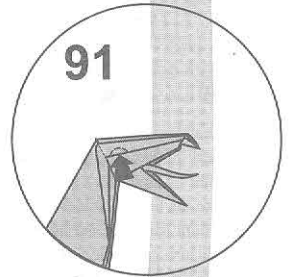

91

Create the eye. Repeat behind.

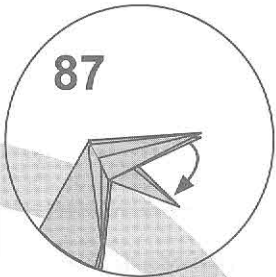

87

Bring down the middle layer.

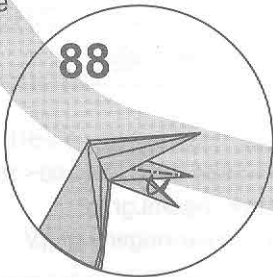

88

Narrow the tongue.

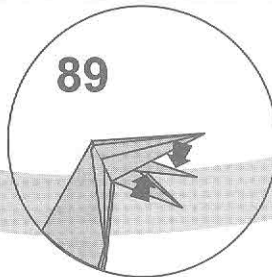

89

Curve the tongue.

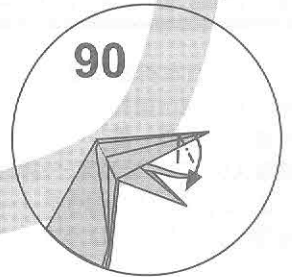

90

Crimp the upper jaw.



ORIGAMI TANTEIDAN  
折紙探偵団  
MAGAZINE

19th CONVENTION 2013

Japan Origami Academic Society

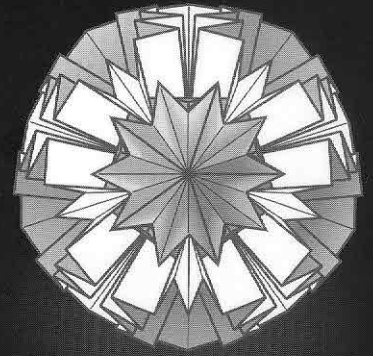

© Miyuki Kawamura

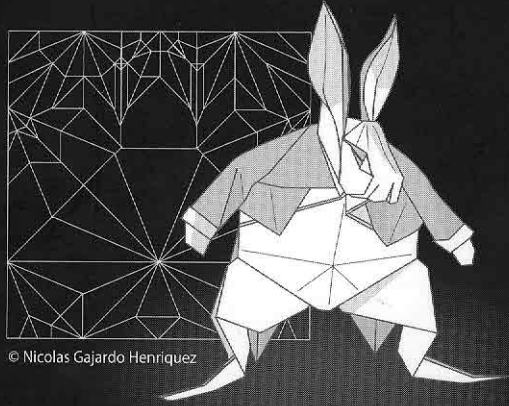

© Nicolas Gajardo Henríquez

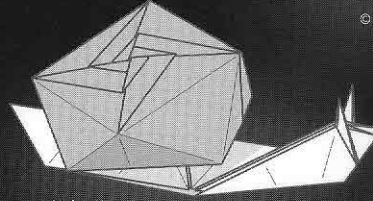

© Hideo Komatsu

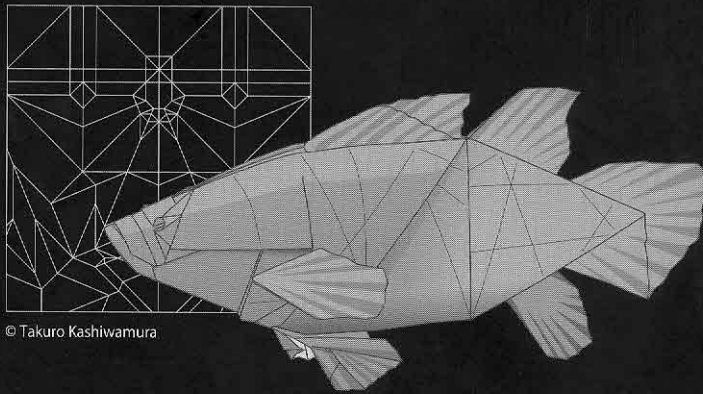

© Takuro Kashiwamura

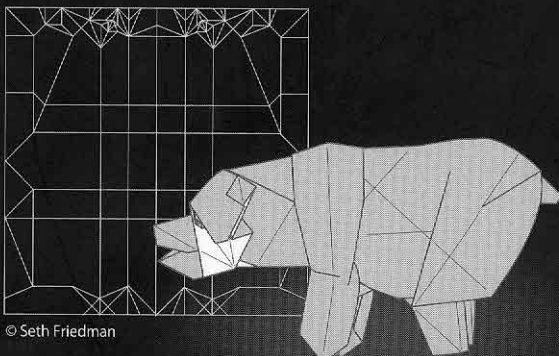

© Seth Friedman

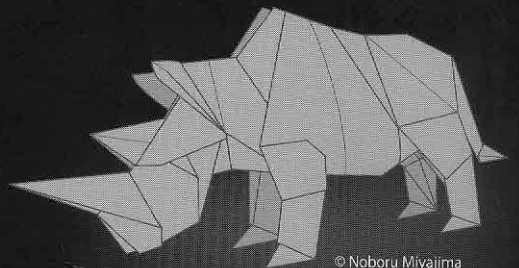

© Noboru Miyajima

定価 2,300円